



EXIDOR
EMERGENCY EXIT HARDWARE

DOOR SEAL RANGE

Exidor now offer a number of seals that function with the Exidor Panic & Emergency Exit Hardware, eliminating the need for keeps to be fitted.

More buildings require Architectural Door Sealing Systems to meet the requirements of Building Regulations, such as Document E and L. Architects, Builders, Door Manufacturers, Joinery Contractors, all need seals to deal with various conditions such as weather, noise, dust, draughts, light, smoke and fire.

The selective seals additionally seal the door opening and conserve energy from leakage of heating and air-conditioning systems.

The seals are designed for areas with a high level of use such as hospitals, airports, factories, shopping centres or areas with a large through-flow of pedestrian and wheeled traffic.

Exidor Panic & Emergency Exit Hardware has been tested and certified by an Independent Test House to offer a CE marked range of hardware when used in conjunction with these seals.

 **National
Seal Systems
Limited**

*Unit 210 Holly Road, Western Industrial Estate,
Naas Road, Dublin 12*

Ph 00353-1-4565170 Fax 00353-1-4502371

Email: info@nationalseal.ie web: www.nationalseal.ie

Exidor offer a wide range of Emergency & Panic Exit Hardware which is CE marked and Fire Rated. The door seals compliment the range and offer a number of benefits, such as the intrusion of sound, fire, smoke, rain, draughts, dust, light, insects and vermin.

All seals are designed to meet most Codes of Practice or Standards and in most cases perform more than one function

	Acoustic BS EN ISO140.3 BS 5821		Insects and Vermin ISO 9972		Fire (approved) BS 476 PT22		Light
	Ambient (cold) Smoke up to 70°C BS 5588		Weather BS 7386, BS8104		Access and Mobility Building Regulations Approved - DOC M		
	Medium Temp. Smoke 200°C for 30 minutes (Smoke Doors) BS 476 PT22		Energy, Draughts & Dust BS EN 10077-1 ISO 8272		Fire & Hot Smoke Fully developed fires exceeding 600°C and hot smoke beyond 200°C (Intumescent Fire Seals)		

ES1 - Threshold Seal

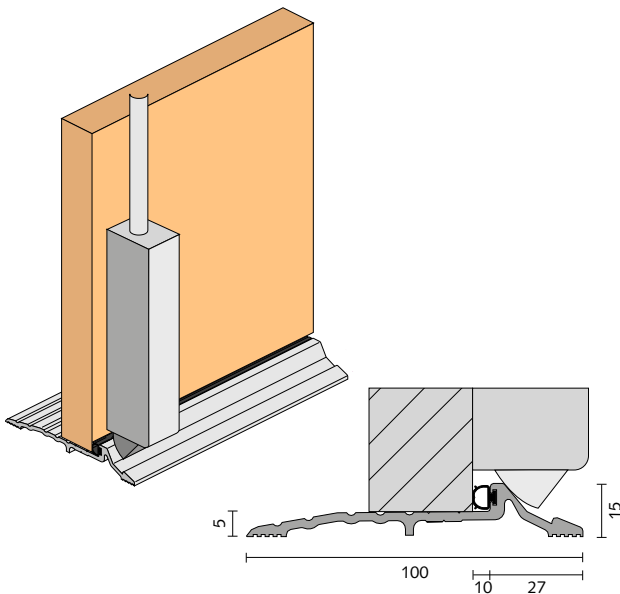

The ES1 is a weather proof threshold plate seal suitable for outward opening broad butt hinged doors. It is ideal for use with Exidor 300 and 400 series exit devices.

For acoustic applications the void under the threshold should be filled with sound foam or other suitable material (by others).

Min/Max: Compression of seal 0mm/2mm.

Location: Door sills (Broad Butt hinges recommended).

Seal lengths: 1000mm & 2000mm

Standard Finish: Anodised Satin aluminium.

Fixing Method:

Zinc plated, cross recess head CSK S.T. screws of the appropriate size and colour are supplied, or can be fastened with builders adhesive for concealed fixing (user determined).

Used in conjunction with Raven door frame seals, astragal seals and Exidor exit devices.

Seal Material: Black Silicon Rubber.

Replacement Seal: RP308Si

Advantages:

- Exidor Panic Hardware will still conform to CE Standard EN179 & EN1125
- No longer need to fit a keep on the floor
- Conforms to the DDA and Building Regulations Document M
- Weather, Fire, Smoke, and Acoustic Seal all in one

ES2 Top Header Seal

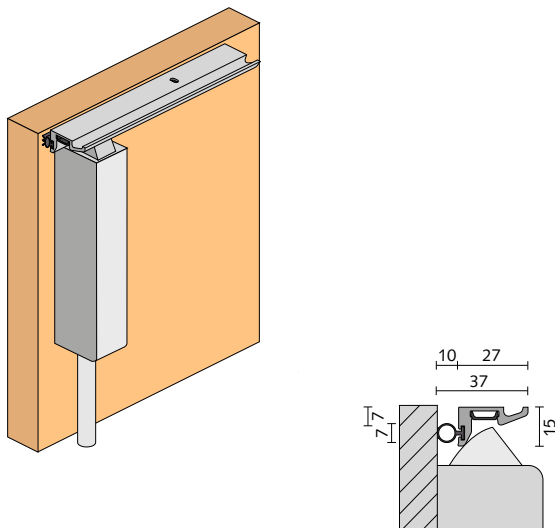

The ES2 is a weather proof header seal suited to outward opening broad butt hinged doors. It is ideal for use with a Exidor 300 and 400 series exit device.

For acoustic applications the void under the threshold should be filled with sound foam or other suitable material (by others).

Min/Max: Compression of seal 0mm/2mm.

Location: Door sills (Broad Butt hinges recommended).

Seal lengths: 1000mm & 2000mm

Standard Finish: Anodised Satin aluminium.

Fixing Method:

Zinc plated, cross recess head CSK S.T. screws of the appropriate size and colour are supplied, or can be fastened with builders adhesive for concealed fixing (user determined).

Used in conjunction with Raven door astragal seals and Exidor exit devices.

Seal Material: Black Silicon Rubber.

Replacement Seal: RP308Si

Advantages:

- Exidor Panic Hardware will still conform to CE Standard EN179 & EN1125
- No longer need to fit a keep on the Header rail
- Weather, Fire, Smoke, and Acoustic Seal all in one

ES3 - Side/Frame Seal

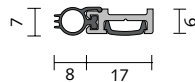
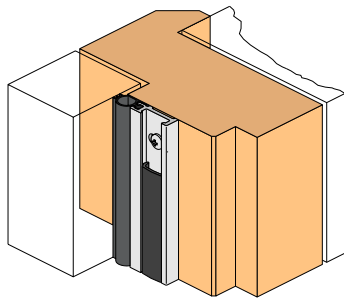

A weather and acoustic seal designed for installation on door stops. Its aluminium carrier is sturdy and slotted for adjustment with concealed fixings. It is quick and easy to install around the jamb and can be fitted without removing the door.

Location: Head and jambs on single or double butt hinged doors.

Min/Max Gap: 0mm to 6mm.

Seal lengths: 2500mm.

Standard Finish: Anodised Satin aluminium

Fixing Method: Zinc plated, cross recess head S.T. screws of the appropriate size are supplied.

Seal Material: Black Silicon Rubber.

Replacement Seal: RP394Si

Advantages:

- Fits to existing frame
- Concealed fixing
- Weather, Fire, Smoke, and Acoustic Seal all in one

ES4 - Side/Frame Seal

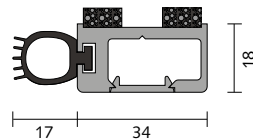
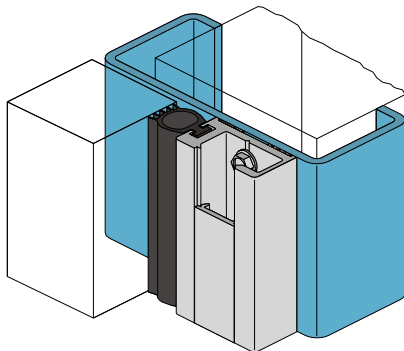

The ES4 has been designed to replace the conventional door stop. Its proven excellent acoustic qualities make it particularly suitable in heavy traffic areas that sustain high abuse, such as in hospitals, hotels, airports and prisons.

Concealed behind an aluminium cover strip can be found a space for low voltage cable management along with adjustable fastener slots for achieving perfect fitment. The extrusions of this rugged tamperproof seal can be mitred or butt jointed for ease of installation. ES4 has been tested acoustically to BS2750 / ISO140 and meets smoke leakage performance of BS 5588.

Location: Jambs of single and double broad butt hinged doors.

Min/Max Gap: 0mm/17mm.

Seal lengths: 2500mm

Standard Finish: Anodised Satin aluminium.

Fixing Method: Zinc plated, self tapping screws (metal) of the appropriate size are supplied.

Seal Material: Black Silicon Rubber.

Replacement Seal: RP347Si.

Advantages:

- Acts as a door stop
- Channel for electrical wiring
- Concealed fixing
- Weather, Fire, Smoke, and Acoustic Seal all in one

ES5 - Centre Door Seal for Double Doors

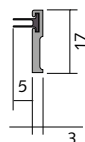
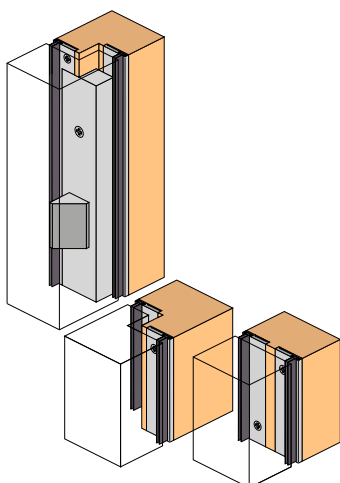

A medium temperature smoke astragal seal designed for plain or rebated meeting stiles of timber double doors where a centre latch bolt may be required, or where both double doors are active. The seal is achieved by a pair of silicon fins that conform to the 200 degrees Celcius requirement of BCA Ref: C3.4.

Two seals are installed onto one door stile, allowing space for a latch between the seals. The aluminium leg of the seal can be cut out to accommodate the latch bolt front plate, thereby providing a continuous seal (minimum door thickness subject to centre latch and dimensions of morticed door bottom seals).

Location: Double broad butt hinged.

Min/Max: Gap 3mm/ 5mm.

Standard Finish: Anodised Satin aluminium.

Seal Length: 2500mm

Fixing Method: Zinc plated, cross recess CSK S.T. screws of the appropriate size and colour are supplied. Fixing holes are pre drilled.

Seal Material: Grey Silicon Rubber.

Replacement Seal: RP371Si.

Advantages:

- Seals the centre of both Plain and Rebated Meeting Stiles on Double Doors
- Weather, Fire, Smoke, and Acoustic Seal all in one

CONSTRUCTION

Aluminium Extruded section with a silicon rubber seal.

MATERIAL

Aluminium Extrusion B6060 TS.

FIXING

The majority of seals are secured using zinc plated self tapping screws. Fixing holes are usually pre-drilled and many are slotted to allow the seals to be fitted accurately and to allow for adjustment.

FINISH

Supplied in Satin Anodised Aluminium.

MAINTENANCE

Periodic inspection, adjustment and cleaning are recommended for all styles of sealing. Normally an annual inspection is sufficient. For fire and smoke sealing applications, refer to National Standards.

DOOR SETS

ES100

- Single Door Set for doors up to 1000mm wide x 2500mm high.
- For use with existing door stops consisting of
 - 1 no. ES1 Threshold Seal 1000mm
 - 1 no. ES2 Top Header Seal 1000mm
 - 2 no. ES3 Side / Frame Seal 2500mm

ES200

- Double Door Set for doors up to 2000mm wide x 2500mm high.
- For use with existing door stops consisting of
 - 1 no. ES1 Threshold Seal 2000mm
 - 1 no. ES2 Top Header Seal 2000mm
 - 2 no. ES3 Side / Frame Seal 2500mm
 - 1 no. ES5 Centre Door Seal for Double Doors 2500mm

ES300

- Single Door Set for doors up to 1000mm wide x 2500mm high.
- For use with no door stops fitted consisting of
 - 1 no. ES1 Threshold Seal 1000mm
 - 1 no. ES2 Top Header Seal 1000mm
 - 2 no. ES4 Side / Frame Seal 2500mm

ES400

- Double Door Set for doors up to 2000mm wide x 2500mm high.
- For use with no door stops fitted consisting of
 - 1 no. ES1 Threshold Seal 2000mm
 - 1 no. ES2 Top Header Seal 2000mm
 - 2 no. ES4 Side / Frame Seal 2500mm
 - 1 no. ES5 Centre Door Seal for Double Doors 2500mm

EXIDOR  RAVEN

**National
Seal Systems
Limited**

Unit 210 Holly Road, Western Industrial Estate.
Naas Road, Dublin 12
Ph 00353-1-4565170 Fax 00353-1-4502371
Email: info@nationalseal.ie web: www.nationalseal.ie