

**National
Seal Systems
&
Limited**



Unit 210 Holly Road, Western Industrial Estate, Naas Road, Dublin 12
Ph: 01 -4565170 **Fax:** 01-4502371 **Email:** -info@nationalseal.ie **Web:** -www.nationalseal.ie



SYSTEM FITTINGS

**FOR OUTWARD OPENING
WINDOWS AND DOORS**

2013

- established 1869 -

IPA + National seal Systems Ltd

WOOD PROFILE

A

HINGES & FITTINGS

B

HINGES & FITTINGS

C

SAFETY CATCH & -RESTRICTORS

D

ESPAGNOLETTE BOLTS

E

ACCESSORIES

F

FURTHER ACCESSORIES

G

MAINTENANCE

H



INDEX

Accessories for Espagnolettes	Page F-10
Accessories for IPA System Fittings	Page G-03 - G-04
Accessories for Mushroom Head Bolt Espagnolettes	Page F-09
Accessories for Roller Bolt Espagnolettes.....	Page F-08
Accessories for Side Bolt Espagnolettes.....	Page F-07
Accessories for Windows	Page G-05 - G-10
Canopy Stays with Adjustable Friction, IPA No. 21167-68 & 21188 (Adjustable)	Page C-07 - C-08
Canopy Stays with Adjustable Friction, IPA No. 21170-75 & 21179-82	Page C-09 - C-10
Canopy Stays - Adjustable - with Adjustable Friction IPA No. 21186-87 & 21189 ...	Page C-13 - C-14
Connection Pieces, IPA No. 23782-90	Page F-05 - F-06
Door Hinge, IPA No. 11195-99 & 200-201	Page B-03 - B-04
Door Hinge - adjustable, IPA No. 12197-98.....	Page B-07
Espagnolettes with Mushroom Head Bolts, IPA No. 23051-60 & 23061-70	Page E-01 - E-02
Espagnolettes with Mushroom Head Bolts, IPA No. 63051-60.....	Page E-25 - E-26
Espagnolettes with Roller Bolts, IPA No. 23151-70.....	Page E-05 - E-06
Espagnolettes with Side Bolts, IPA No. 23701-10 & 23715-24	Page E-07 - E-08
Espagnolettes with Side Bolts, IPA No. 23745-54 & 23760-69	Page E-09 - E-10
Espagnolettes with Side Bolts, IPA No. 23841-48	Page E-11 - E-12
Espagnolettes with Side Bolts, IPA No. 23121-24	Page E-13 - E-14
Espagnolettes with Side Bolts for Patio Doors, IPA No. 23551-53.....	Page E-15 - E-16
Espagnolettes with Side Bolts, IPA No. 23141-48 & 23285-86	Page E-03 - E-04
Espagnolettes 2-Parts with Side Bolts for Patio Doors, IPA No. 23461 & 23462-67	Page E-17 - E-18
Espagnolettes 2-Parts with Side Bolts for Patio Doors, IPA No. 23481 & 23482-87	Page E-19 - E-20
Espagnolettes 2-Parts with Side Bolts for Patio Doors, IPA No. 23498 & 23482-87	Page E-21 - E-22
Espagnolettes for low positioning of Handle, IPA No. 23131-34	Page E-23 - E-24
Extention Pieces, IPA No. 23580-97.....	Page F-11 - F-12
Fire Escape Catch, IPA No. 21156	Page D-13
Fire Escape Fitting, IPA No. 21321.....	Page D-10
Friction Stay for Doors, adjustable, IPA No. 22411.....	Page G-02
Friction Stay for Doors, IPA No. 23820-23.....	Page F-03 - F-04
Friction Stay for Windows - Adjustable, IPA No. 21327	Page G-01
Friction Stay for Windows and Frame Fixtures, IPA No. 23810-18, 23797-99 & 23801-03.....	Page F-01 - F-02
Fully Reversible Fittings for Side Swing Windows 180°, IPA No. 21281-86.....	Page B-15 - B-16
Fully Reversible Fittings for Side Swing Windows 180°, IPA No. 21290-95.....	Page B-13 - B-14
Handles for Window Espagnolettes.....	Page F-14
Hinge for Coupled Sash Windows with Sash Couplers, IPA No. 11715.....	Page B-05
Hinge for Coupled Sash Windows with Sash Couplers, IPA No. 11717-18.....	Page B-06
Hinges for Side Hung Windows, IPA No. 11166-67, 11173-74 & 11177-79	Page B-01 - B-02
Hinge Positions - Suggestion	Page A-06



INDEX

IPA Number Index.....	Page I-01 - I-04
Maintenance	Page H-01 - H-04
Number of Hinges - Suggestion	Page A-05
Reversible Projecting Gears, IPA No. 21044-52.....	Page C-03 - C-04
Reversible Projecting Gears, IPA No. 21144-52.....	Page C-05 - C-06
Reversible Projecting Gears, IPA No. 21874-82.....	Page C-11 - C-12
Safety Restrictor, IPA No. 21158	Page D-15
Safety Restrictor, IPA No. 21160	Page D-01 - D-02
Safety Restrictors, IPA No. 21162-63	Page D-16
Safety Restrictor, IPA No. 21228	Page D-03 - D-04
Safety Restrictor, IPA No. 21230	Page D-05 - D-06
Safety Restrictor, IPA No. 21231	Page D-07
Safety Restrictor, IPA No. 21232	Page D-19 - D-20
Safety Restrictor, IPA No. 21233	Page D-08
Safety Restrictor, IPA No. 21236	Page D-11
Shootbolts Extentions, IPA No. 23780.....	Page F-13
Side Swing Window 90° with friction, IPA No. 21193.....	Page B-09 - B-10
Side Swing Window 90° with friction, IPA No. 21194-95.....	Page B-11 - B-12
Support Fitting - Adjustable, IPA No. 21226	Page D-12
Support Rail, IPA No. 21227	Page D-03 - D-04
Support Rail, IPA No. 21229.....	Page D-05 - D-06
Top Hinge, IPA No. 21125.....	Page C-01
Top Hinge, IPA No. 21127-28	Page C-02
Ventilation Catch, IPA No. 21157.....	Page D-14
Wood Profile - Example.....	Page A-03 - A-04



IPA SYSTEM FITTINGS

A COMPREHENSIVE RANGE OF FITTINGS FOR WINDOWS AND DOORS WHICH ALL FIT INTO THE SAME WOOD PROFILE.

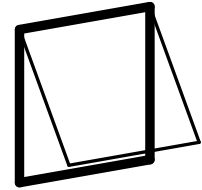
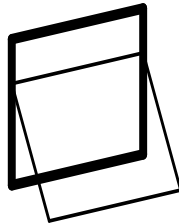
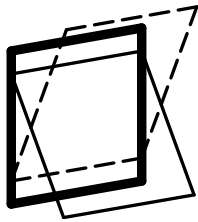

THE ORIGINAL IPA SYSTEM GROOVE

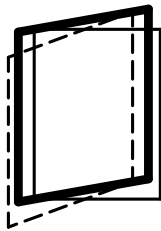

17,3 X 3 MM
GROOVE IN
THE SASH

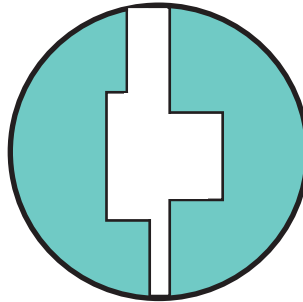

12 X 7 MM
GROOVE IN
THE FRAME

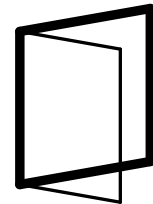

DEVELOPED BY IPA MORE THAN 30 YEARS AGO

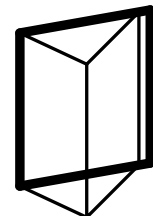
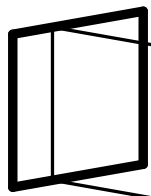
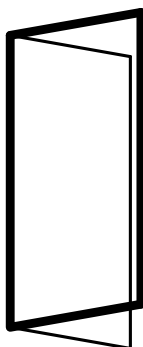

BY USING THE SAME PROFILE FOR DIFFERENT TYPES OF WINDOWS YOU WILL ACHIEVE MORE FLEXIBLE PRODUCTION - REDUCE MANUFACTURING TIME - DECREASE STOCKING LEVELS - AND SAVE ON OVERALL OPERATING COSTS.



The IPA SYSTEM FITTINGS represent a genuine break-through for flexible production of windows and doors.

The IPA SYSTEM FITTINGS are precision made and developed through many years experience - and the development will continue.

IPA - has probably the largest and most efficient range of architectural ironmongery today. The following information is designed to assist window and door manufacturers in selecting the proper series of IPA SYSTEM FITTINGS.

IPA SYSTEM for flexible production.

It is important to study each fitting instruction very carefully and position the fittings properly in the rebates which are 12x7 mm in the frame and 17,3x3 mm in the sash.

In this brochure you will find all the IPA SYSTEM articles with No's, descriptions, specifications of window escape opening as well as fitting instructions.

In case you might want supplementary information concerning the fittings mentioned above, we shall be pleased to be at your service.





SYSTEM FITTINGS

EXAMPLE - WOOD PROFILE

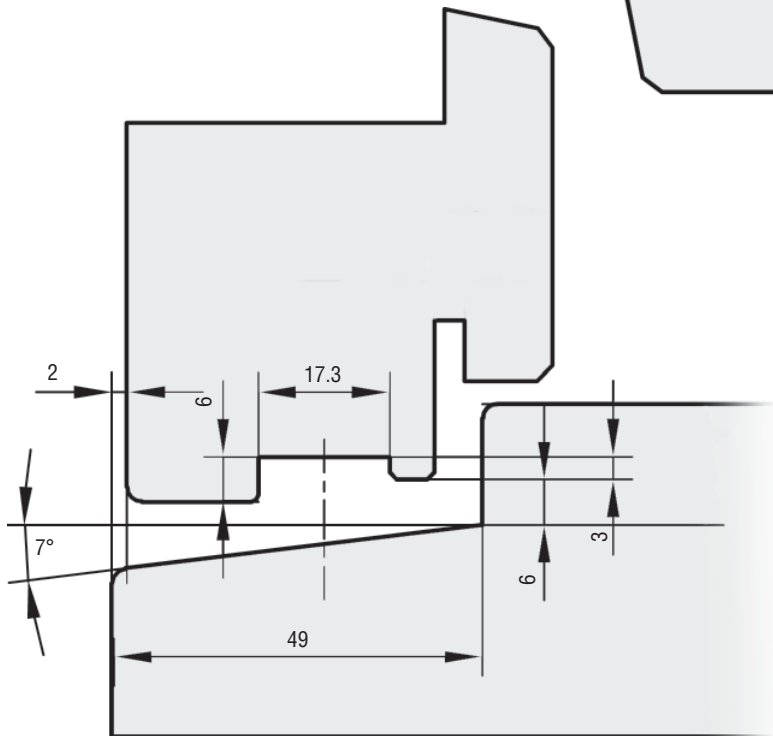
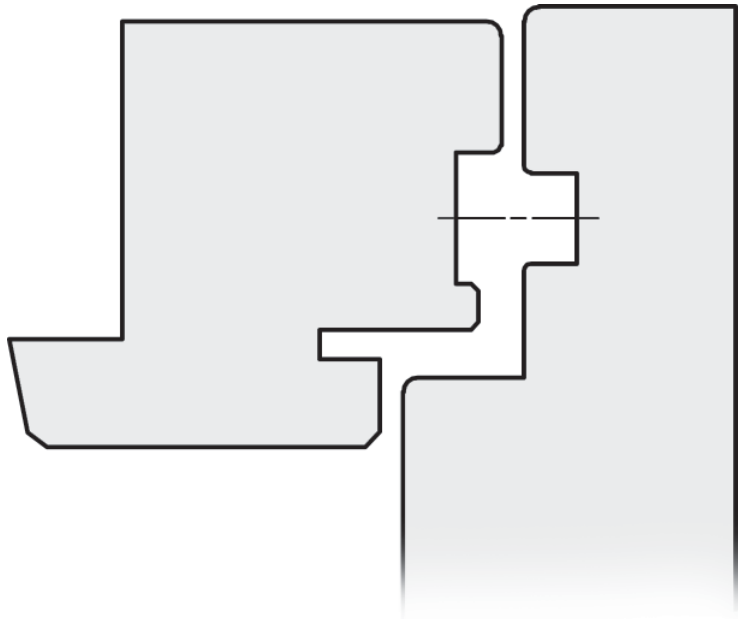
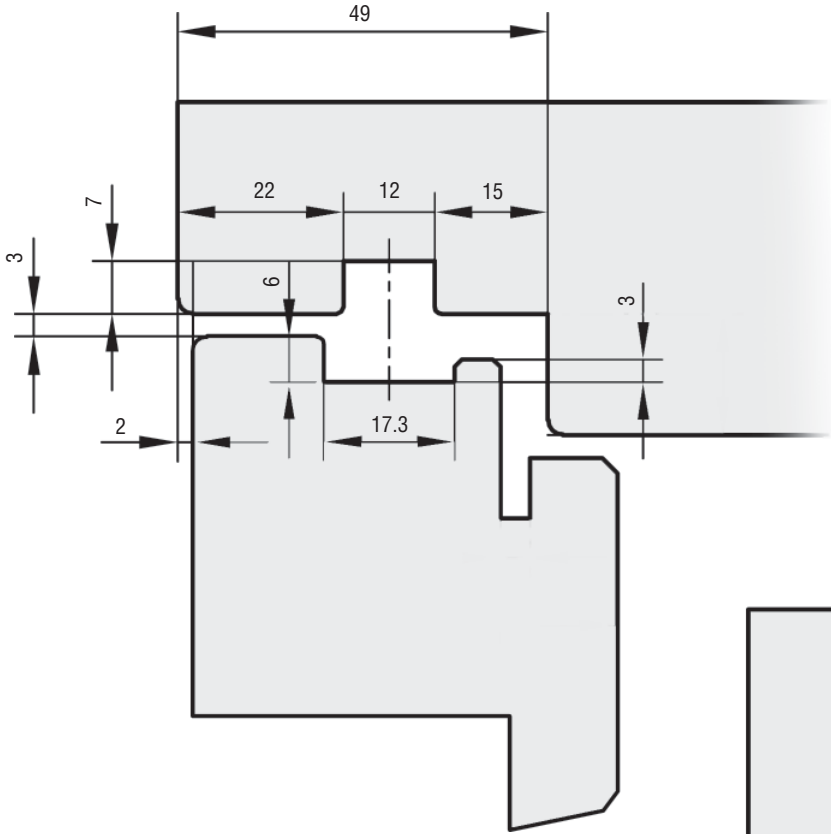



SYSTEM FITTINGS

EXAMPLE - WOOD PROFILE

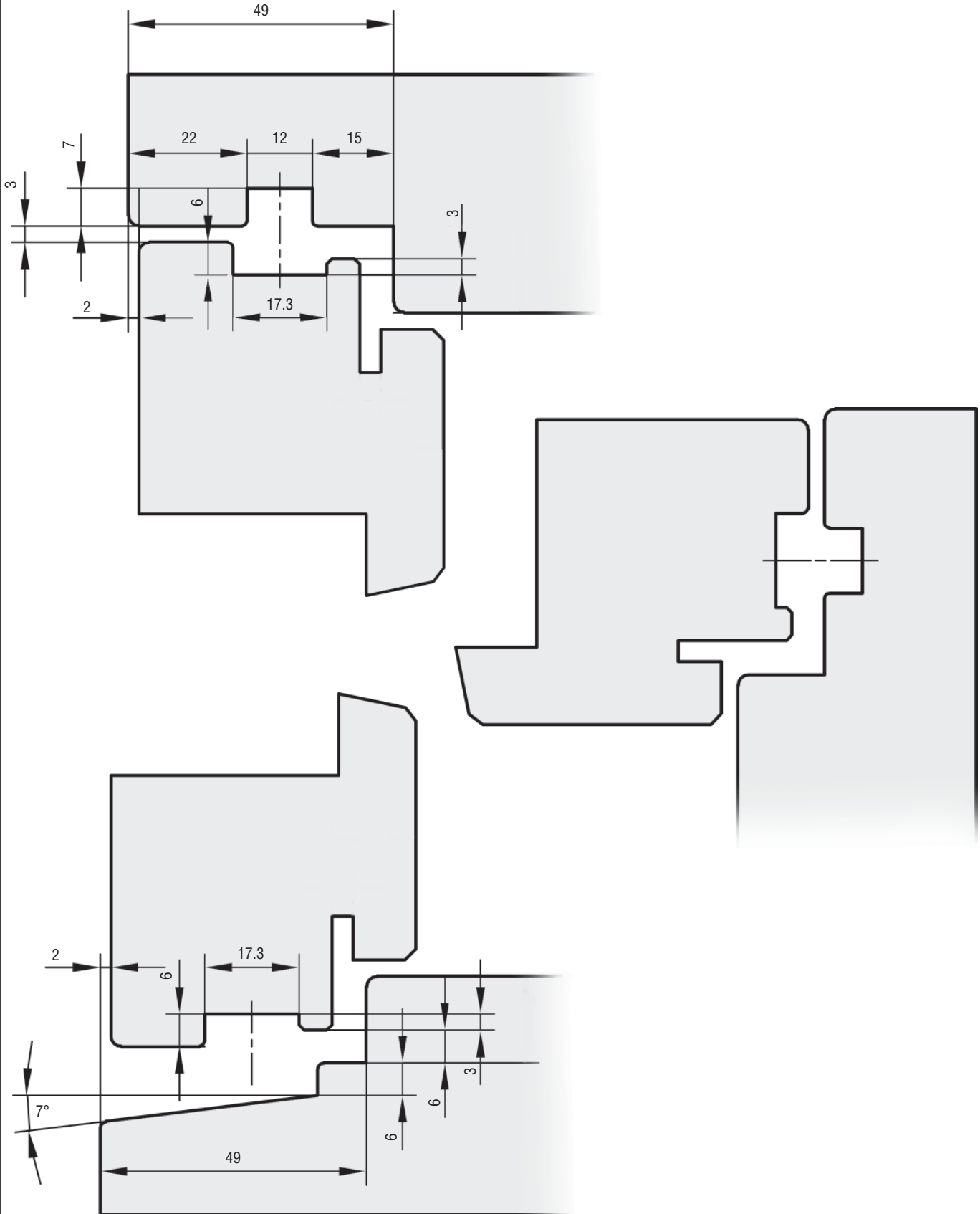



SYSTEM FITTINGS

SUGGESTION - NUMBER OF HINGES

The charts below show the number of hinges, we suggest to use on different sizes of windows and doors. The charts shall ONLY be considered as a guidance, as the number of hinges also will depend on the use and weight of the window/door. If the window/door is mounted in a public building with many users (Schools, Railway Stations etc.) then more or even larger hinges are recommended.

Also we suggest to use a support fitting whenever possible.

WINDOW HINGES: Valid for the window hinges shown in this catalogue.

All window hinges meets the requirements of class 9 (60 Kgs.) in accordance with DS/EN 1935. The numbers in brackets are number of hinges in windows with 3-layer glass.

Width \ Height	500	600	700	800
1500	2 (3)	3 (3)	3 (3)	3 (4)
1400	2 (3)	3 (3)	3 (3)	3 (4)
1300	2 (3)	3 (3)	3 (3)	3 (4)
1200	2 (3)	3 (3)	3 (3)	3 (4)
1100	2 (3)	3 (3)	3 (3)	3 (3)
1000	2 (2)	2 (2)	2 (2)	3 (3)
900	2 (2)	2 (2)	2 (2)	3 (3)
800	2 (2)	2 (2)	2 (2)	3 (3)
700	2 (2)	2 (2)	2 (2)	
600	2 (2)	2 (2)		
500	2 (2)			

DOORHINGES: Valid for door hinges shown in this catalogue.

All door hinges with steel pin meets the requirements of class 13 (120 Kgs.) in accordance with DS/EN 1935. The same hinges with brass pin meets the requirements of class 11 (80 Kgs.) in accordance with DS/EN 1935

Width \ Height	700	800	900	1000	1100
2600	5	5	5		
2500	5	5	5	5	
2400	4	4	4	5	5
2300	4	4	4	4	5
2200	3	3	3	4	4
2100	3	3	3	3	4
2000	3	3	3	3	4



SYSTEM FITTINGS

SUGGESTION - HINGE POSITIONS

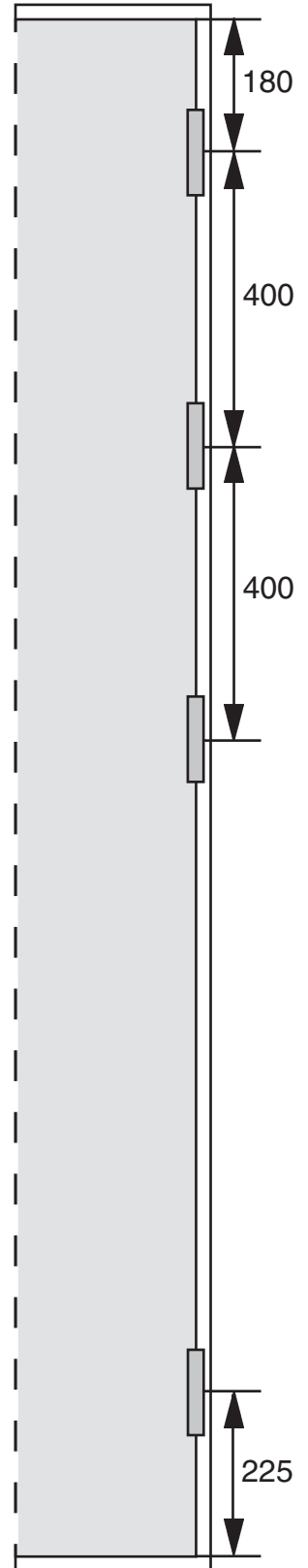
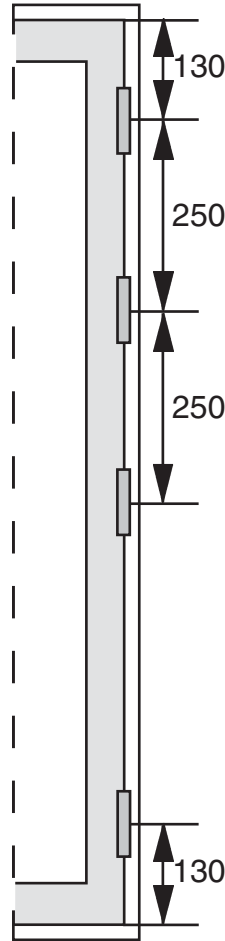
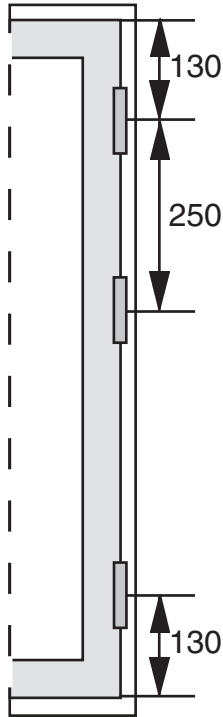
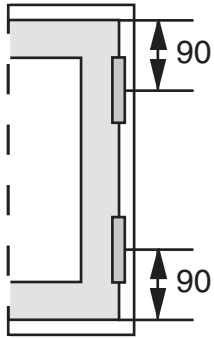



HINGES FOR SIDE HUNG WINDOWS

IPA NO.s 11166-67, 11173-74 & 11177-79

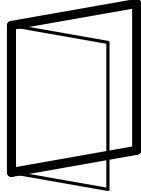

ORDERING NO.															A MM	B MM	C MM	THICKNESS PLATE M,MM	PIN MM	SCREW	APPROX WEIGHT KG/EACH		
IPA NO.	MATERIAL				SURFACE							STANDARD PACKING IN BOXES OF 10 PIECES	INDUSTRY PACKING IN BOXES OF 100 PIECES	INDUSTRY PACKING IN PALLETS OF 1800 PIECES									
	STEEL FIXED STEEL PIN	STEEL FIXED BRASS PIN	BRASS FIXED STEEL PIN	STAINLESS STEEL	SQUARE EDGES LEFT	SQUARE EDGES RIGHT	ELECTROPL./WHITE	ELECTROPLATED	ELECTROPL. YELLOW	ELECTROPL./GREY	POLISHED				UNMACHINED	GALVANIZED							
11166	2	-	-	-	3	4	-	-	-	64	-	-	87	-	2	-	90	47	49,5	2,8	8	4,0	0,19
	-	3	-	-	3	4	-	-	-	-	-	-	87	-	2	-							
11167	2	-	-	-	3	4	-	-	-	64	-	-	87	-	2	-	90	50	52,5	2,8	8	4,0	0,20
11173	2	-	-	-	3	4	-	-	25	64	-	-	-	-	2	-	70	37	39,5	2,5	8	4,0	0,13
	-	3	-	-	3	4	-	-	25	-	-	-	87	1	2	-							
	-	3	-	-	3	4	06	21	-	-	-	-	-	1	-	-							
11174	2	3	-	-	3	4	-	-	-	-	-	-	87	1	2	-	90	37	39,5	2,5	8	4,0	0,17
	-	3	-	-	3	4	-	-	-	-	-	-	-	-	-	3							
	-	3	-	-	3	4	-	21	-	-	-	-	-	-	2	-							
	-	3	-	-	3	4	-	-	-	25	-	-	-	1	2	-							
	-	3	-	-	3	4	06	-	-	-	-	-	-	1	-	-							
	-	-	7	-	3	4	-	-	-	-	85	-	-	1	-	-							
11177	-	3	-	-	3	4	-	-	-	-	-	-	87	1	2	-	90	37	39,5	2,5	8	4,0	0,19
	-	3	-	-	3	4	06	-	-	-	-	-	-	1	-	-							
11178	-	3	-	-	3	4	06	-	-	-	-	-	87	1	-	-	90	37	39,5	2,5	8	4,0	0,16
11179	-	3	-	-	3	4	06	-	-	-	-	-	87	1	-	-	90	37	39,5	2,5	8	4,0	0,19

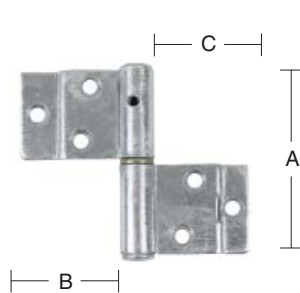

11166-67 + 11173-74
RIGHT HAND

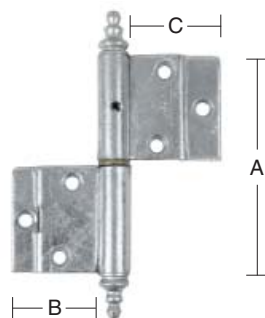

11177
RIGHT HAND

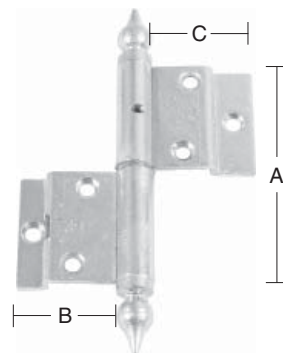

11178
RIGHT HAND

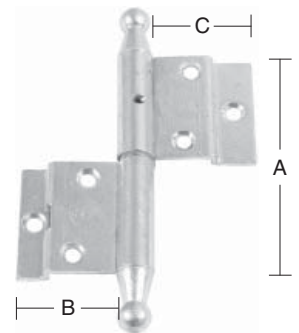

11179
RIGHT HAND



FITTING INSTRUCTIONS

EXAMPLE WOOD PROFILE

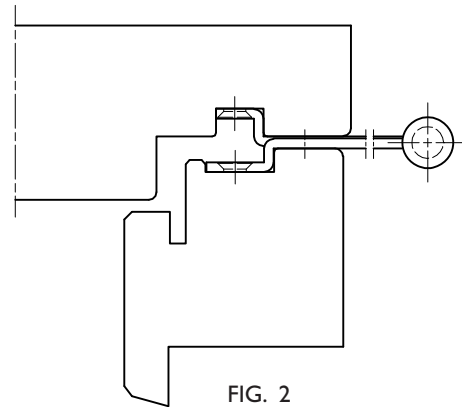
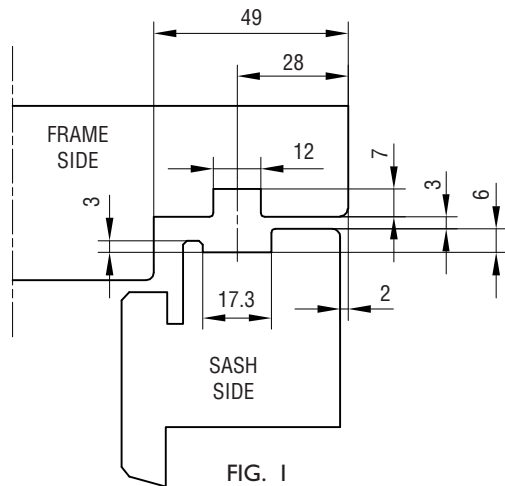

MAINTENANCE:

TEST THE OPERATION FROM TIME TO TIME.

WHEN FITTING - GREASE THE PIVOT/MOVABLE METAL PARTS OF THE MECHANISM WHILE ACTIVATING REPEATEDLY. HEREAFTER GREASE MINIMUM TWICE A YEAR. SEE ALSO SECTION H.



DOOR HINGE

IPA NO.s 11195-99 & 11200-201

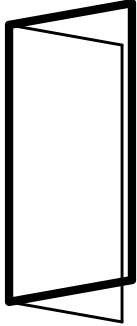

ORDERING NO.														A MM	B MM	C MM	D MM	E MM	THICKNESS PLATE M,M	PIN MM	SCREW	APPROX WEIGHT KG /EACH		
IPA NO.	MATERIAL				SURFACE								STANDARD PACKING IN BOXES OF 10 PIECES										INDUSTRY PACKING IN BOXES OF 50 PIECES	
	STEEL FIXED STEEL PIN	STEEL FIXED BRASS PIN	BRASS FIXED STEEL PIN	STAINLESS STEEL	SQUARE EDGES LEFT	SQUARE EDGES RIGHT	ELECTROPL./WHITE	ELECTROPLATED	ELECTROPL./YELLOW	ELECTROPL./GREY	POLISHED	UNMACHINED		GALVANIZED										
11195	2	-	-	-	3	4	-	-	-	-	-	-	87	1	-	120	69	61,5	12	17	4	9,5	5,0	0,53
11197	2	-	-	-	3	4	-	-	-	64	-	-	87	-	2	120	59	51,5	12	17	4	9,5	5,0	0,48
	-	3	-	-	3	4	-	-	-	-	85	-	-	1	-									
11198	2	-	-	-	3	4	-	21	25	64	-	-	87	-	2	120	49	41,5	12	17	4	9,5	5,0	0,43
	2	-	-	-	3	4	-	-	-	-	-	-	87	1	-									
	-	3	-	-	3	4	-	21	-	-	-	-	-	-	2									
	-	3	-	-	3	4	-	-	-	25	-	-	87	1	2									
	-	3	-	-	3	4	06	-	-	-	-	-	-	1	-									
	-	-	7	-	3	4	-	-	-	-	85	-	-	1	-									
11199	-	3	-	-	3	4	06	-	-	-	-	-	87	1	-	120	49	41,5	12	17	4	9,5	5,0	0,5
11200	-	3	-	-	3	4	06	-	-	-	-	-	87	1	-	120	49	41,5	12	17	4	9,5	5,0	0,5
11201	-	3	-	-	3	4	06	-	-	-	-	-	87	1	-	120	49	41,5	12	17	4	9,5	5,0	0,5

THREADED BACK PLATE IPA NO. 12721 - SEE PAGE G-03

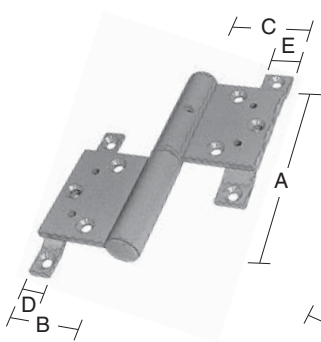

11195+11197-98
RIGHT HAND

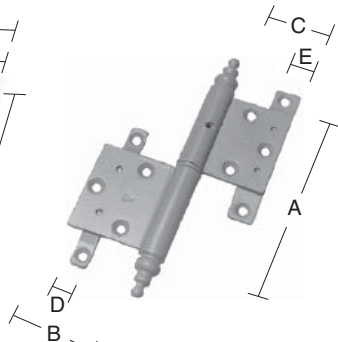

11199
RIGHT HAND

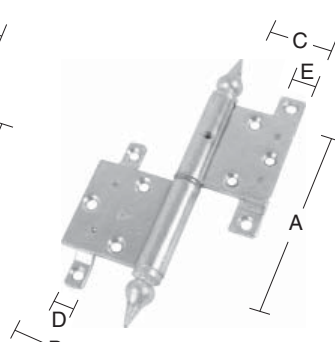

11200
RIGHT HAND

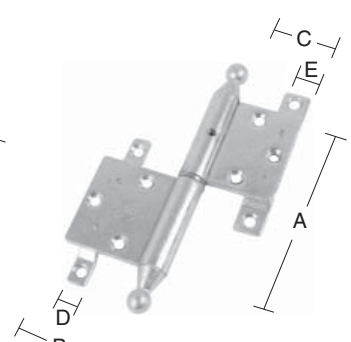

11201
RIGHT HAND



FITTING INSTRUCTIONS

EXAMPLE WOOD PROFILE

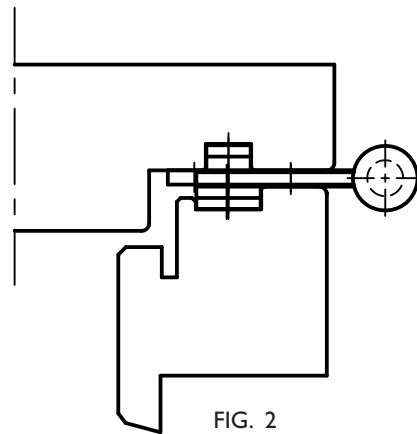
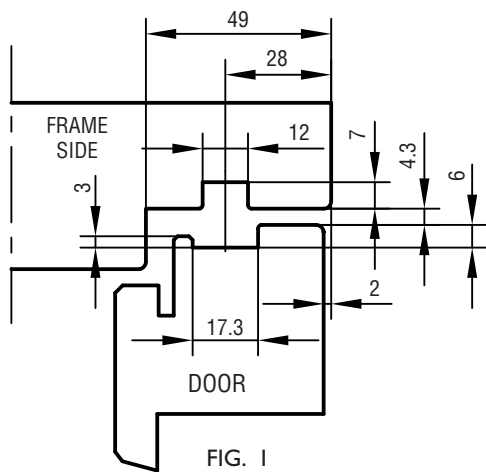

MAINTENANCE:

TEST THE OPERATION FROM TIME TO TIME.

WHEN FITTING - GREASE THE PIVOT/MOVABLE METAL PARTS OF THE MECHANISM WHILE ACTIVATING REPEATEDLY. HEREAFTER GREASE MINIMUM TWICE A YEAR. SEE ALSO SECTION H.



HINGE FOR COUPLED SASH WINDOWS WITH SASH COUPLERS IPA NO. 11715

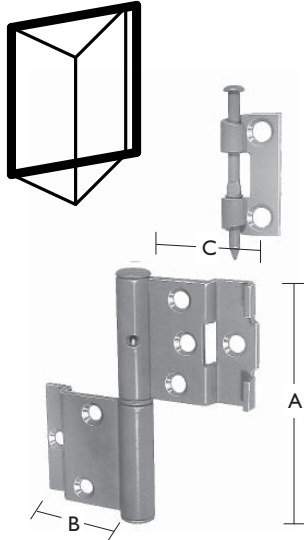

RIGHT HAND

ORDERING NO.													
IPA NO.	MATERIAL		SURFACE			A MM	B MM	C MM	THICKNESS PLATE MM	PIN MM	SCREW	APPROX. WEIGHT KG/EACH	
	STEEL FIXED BRASS PIN	SQUARE EDGES LEFT	SQUARE EDGES RIGHT	GALVANIZED	STANDARD PACKING IN BOXES OF 10 PIECES								INDUSTRY PACKING IN BOXES OF 100 PIECES
11715	3	3	4	87	1	2	90	36,5	39	2,5	8	4,0	0,19

COUPLING HINGES IPA NO.s 13241-43 - SEE PAGE G-03.



FITTING INSTRUCTIONS

EXAMPLE WOOD PROFILE

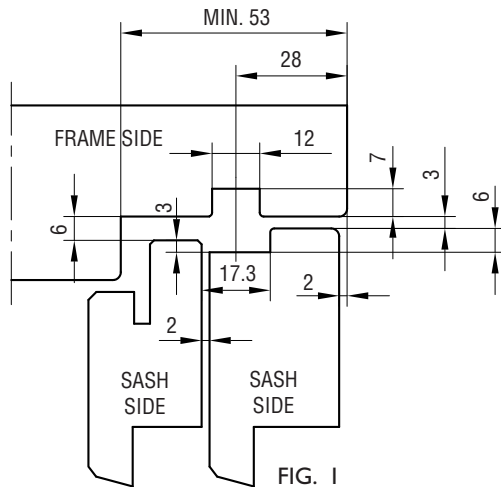

FIG. 1

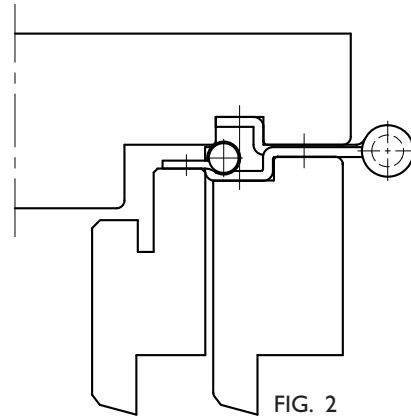

FIG. 2

MAINTENANCE:

TEST THE OPERATION FROM TIME TO TIME.

WHEN FITTING - GREASE THE PIVOT/MOVABLE METAL PARTS OF THE MECHANISM WHILE ACTIVATING REPEATEDLY. HEREAFTER GREASE MINIMUM TWICE A YEAR.

SEE ALSO SECTION H.



HINGES

FOR COUPLED SASH WINDOWS WITH SASH COUPLERS IPA NO.s 11717-18

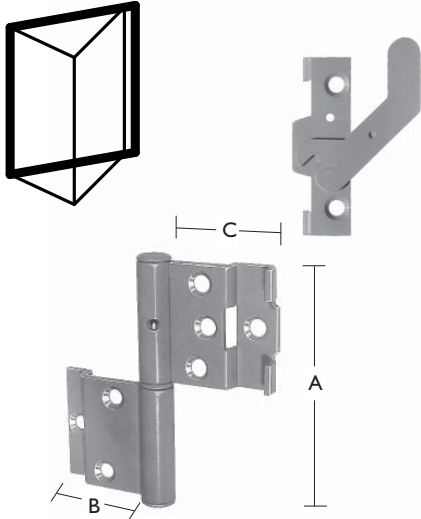

RIGHT HAND

IPA NO.	ORDERING NO.													
	MATERIAL		SURFACE			STANDARD PACKING IN BOXES OF 10 PIECES	INDUSTRY PACKING IN BOXES OF 100 PIECES	A MM	B MM	C MM	THICKNESS PLATE MM	PIN MM	SCREW	APPROX. WEIGHT KG/EACH
	STEEL FIXED BRASS PIN	SQUARE EDGES LEFT	SQUARE EDGES RIGHT	GALVANIZED										
11717	3	3	4	87	1	-	90	36,5	39	2,5	8	4,0	0,20	
11718	3	3	4	87	1	2	90	36,5	39	2,5	8	4,0	0,22	

COUPLING HINGES IPA NO.s 13241-43 - SEE PAGE G-03.

IPA NO. 11718 IS WITH SPECIAL FINIALS →



FITTING INSTRUCTIONS

EXAMPLE WOOD PROFILE

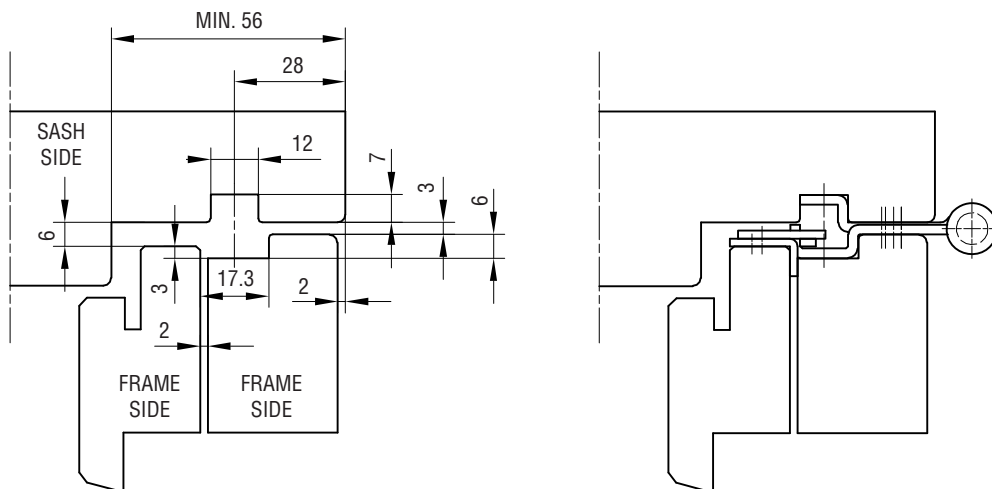

MAINTENANCE:

TEST THE OPERATION FROM TIME TO TIME.

WHEN FITTING - GREASE THE PIVOT/MOVABLE METAL PARTS OF THE MECHANISM WHILE ACTIVATING REPEATEDLY. HEREAFTER GREASE MINIMUM TWICE A YEAR. SEE ALSO SECTION H.



DOOR HINGE - ADJUSTABLE

IPA NO. 12197-98

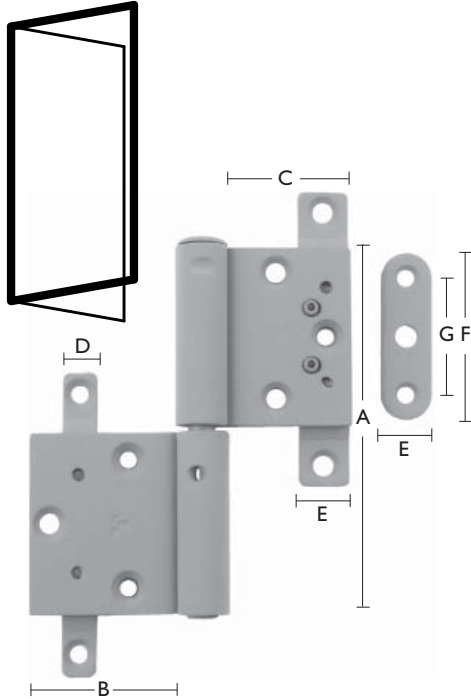

ORDERING NO.																	
IPA NO.	MATERIAL		SURFACE				A MM	B MM	C MM	D MM	E MM	F MM	G MM	PLATE MM	PIN MM	SCREW	
	STEEL FIXED PIN	SQUARE EDGES LEFT	SQUARE EDGES RIGHT	ELECTROPL. YELLOW	GALVANIZED	STANDARD PACKING IN BOXES OF 10 PIECES											INDUSTRY PACKING IN BOXES OF 50 PIECES
12197	2	3	4	-	87	-	2	120	59	51,5	12	17	57	40	4	9,5	5,0
12198	2	3	4	25	-	1	-	120	49	41,5	12	17	57	40	4	9,5	5,0
				-	87	1	2	120	49	41,5	12	17	57	40	4	9,5	5,0

THREADED BACK PLATE IPA NO. 12721 - SEE PAGE G-03

- HORIZONTALLY AND VERTICALLY ADJUSTABLE
- FITS INTO IPA SYSTEM GROOVES
- SAME DIMENSIONS AS IPA NO. 11197 AND 11198
- PIN SUPPORTED HINGE WITH ADJUSTABLE BALL BEARING



FITTING INSTRUCTIONS

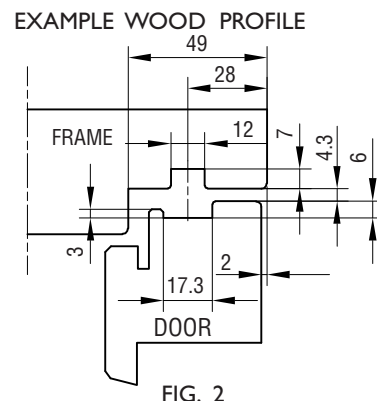
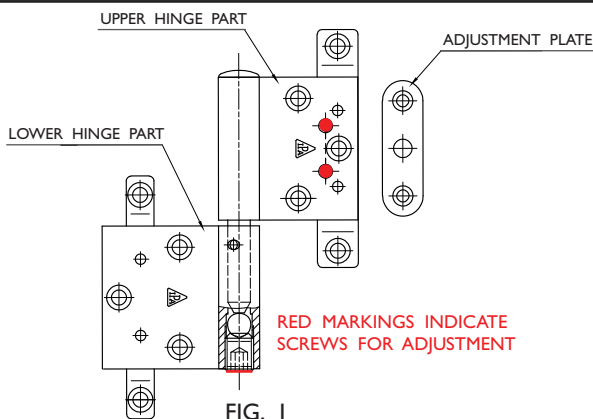

FITTING:

1. MOUNT THE ADJUSTMENT PLATE IN THE GROOVE OF THE DOOR IN THE MIDDLE OF WHERE THE UPPER HINGE PART IS BEING MOUNTED.
2. PLACE THE UPPER HINGE PART OVER THE ADJUSTMENT PLATE AND FASTEN IT. THE ADJUSTMENT SCREWS SHOULD BE LOOSENED.

ADJUSTMENT:

- HORIZONTALLY:**
LOOSEN THE MOUNTING SCREWS AND ADJUST TO WANTED POSITION. FASTEN THE MOUNTING SCREWS.
- VERTICALLY:**
ADJUST TO WANTED POSITION ON THE LARGE SCREW AT THE BOTTOM OF THE HINGE - ±3 MM.

MAINTENANCE:

TEST THE OPERATION FROM TIME TO TIME. WHEN FITTING - GREASE THE PIVOT/MOVABLE METAL PARTS OF THE MECHANISM WHILE ACTIVATING REPEATEDLY. HEREAFTER GREASE MINIMUM TWICE A YEAR. SEE ALSO SECTION H.



Blank white rectangular area for notes or diagrams.



FITTING INSTRUCTIONS

Blank white rectangular area for fitting instructions.



SIDE SWING WINDOW 90° WITH FRICTION IPA NO. 21193

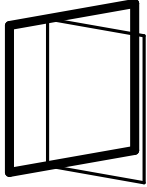

ORDERING NO.										
IPA NO.	MATERIAL			SURFACE	STANDARD PACKING IN BOXES OF 5 SETS	A MM	B MM	C MM	SCREW	APPROX. WEIGHT KG/SET
	STEEL	LEFT HAND	RIGHT HAND	ELECTROPLATED						
21193	1	7	8	21	1	12	36	313	4,0	0,55

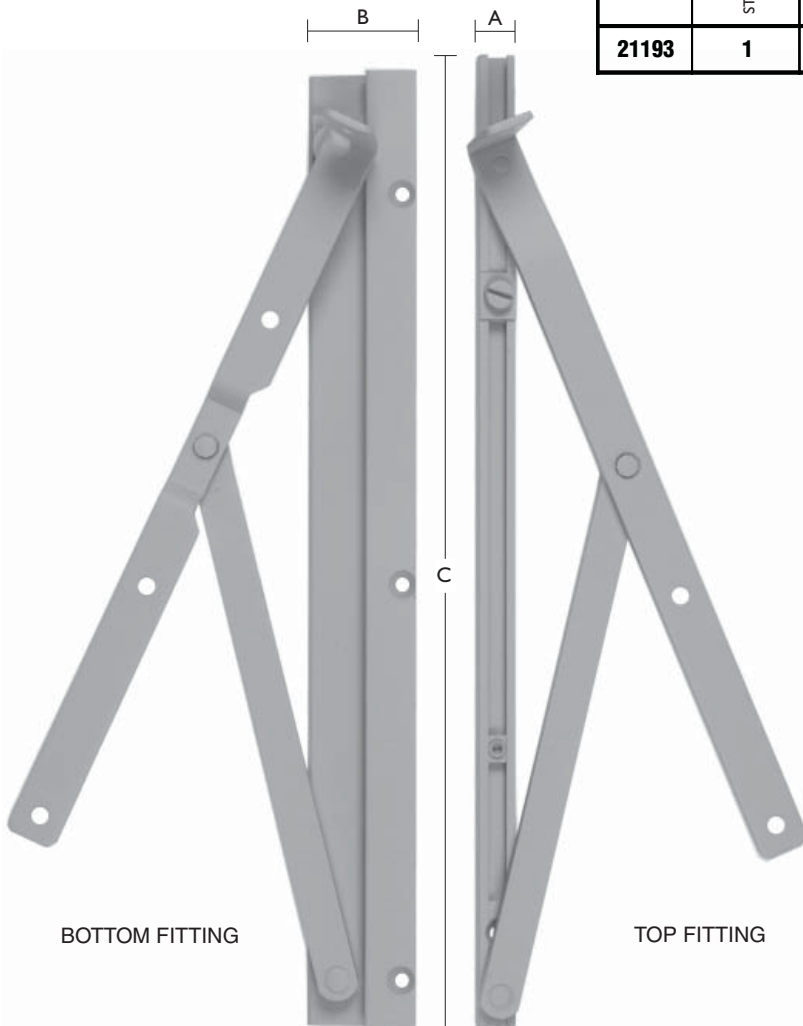

BOTTOM FITTING

TOP FITTING

1 SET
LEFT HAND

- CONVINIENT FOR CLEANING
- SWINGS 90°
- OPENS CLEAR FROM CURTAINS AND WINDOW FRAME
- MAX. VENTILATION
- CONCEALED FITTINGS
- FRICTION IN ALL POSITIONS
- ADJUSTABLE FRICTION
- ANODIZED ALUMINIUM RAILS
- EASY TO OPERATE
- EASY TO FIT
- ELECTROPLATED STEEL PARTS



FITTING INSTRUCTIONS

WHEN MANUFACTURING THE WINDOW AND MOUNTING THE FITTINGS THE SLIDING SHOES NEED TO BE IN CENTER POSITION IN THE ALUMINIUM PROFILE, THIS ENABLES THE WOOD TO WORK. WHEN MOUNTING THE WINDOW THE TOP AND BOTTOM FRAME SHOULD BE PARALLEL. THIS IS NECESSARY, IN ORDER TO LET THE SLIDING SHOES GLIDE WITHOUT FRICTION IN THE ALUMINIUM PROFILE.

IMPORTANT:

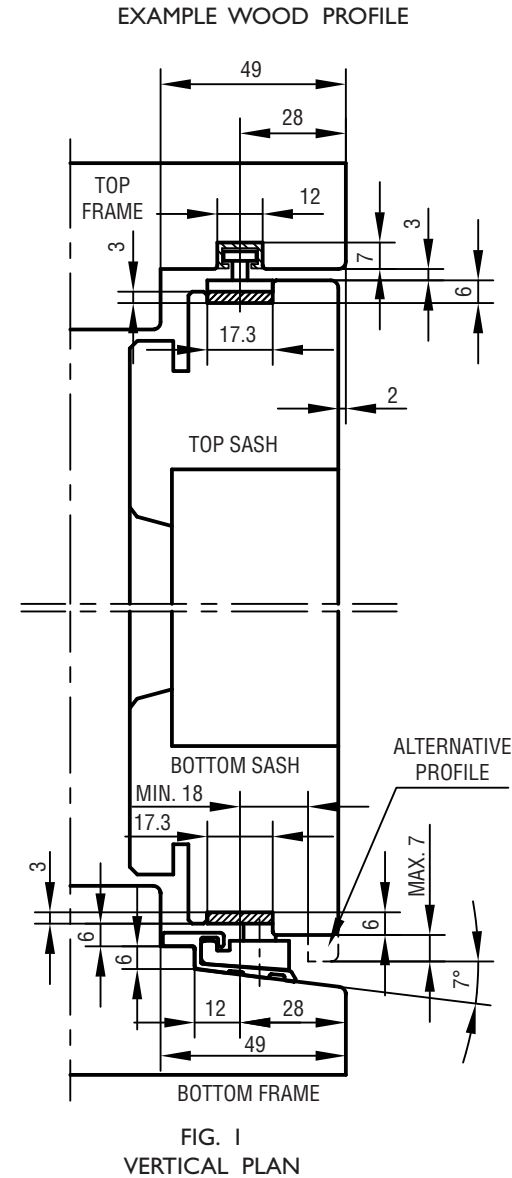

FIG. 1
VERTICAL PLAN

FITTING:

1. THE FITTING SHOULD BE POSITIONED IN THE GROOVES AT HEAD AND CILL OF FRAME AND SCREWED ON (FIGURE 1 AND 2)
2. NOW PUSH THE WINDOW SASH INTO POSITION BY SASH SLOTS AND FASTEN THE SCREWS.
3. NOW THE FRICTION CAN BE ADJUSTED BY MEANS OF THE NYLON SCREW ON THE TOP FITTING.

MAINTENANCE:

THE FITTINGS ARE NOT TO BE PAINTED. TEST THE OPERATION FROM TIME TO TIME. WHEN FITTING - LUBRICATEE THE PIVOT/MOVABLE METAL PARTS OF THE MECHANISM WHILE ACTIVATING REPEATEDLY. HEREAFTER LUBRICATE MINIMUM TWICE A YEAR. DO NOT LUBRICATE THE ALUMINIUM RAILS. SEE ALSO SECTION H.

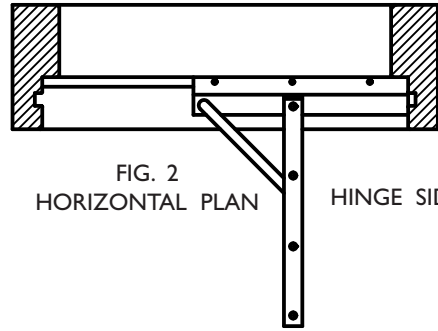

FIG. 2
HORIZONTAL PLAN HINGE SIDE

FITTING SHOWN ON FRAME CILL
RIGHT HAND ILLUSTRATION

IPA NO.	21193
MAX. WEIGHT OF SASH KGS	40
MIN. WIDTH OF SASH	320
MAX. WIDTH OF SASH	820
USE SCREW NO.	4,0

FIG. 3

FRAME SIDE AND SASH SIDE NEED TO HAVE THE SAME PROFILE AS TOP FRAME AND TOP SASH.



SIDE SWING WINDOW 90° WITH FRICTION IPA NO. 21194-95

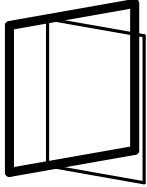

ORDERING NO.										
IPA NO.	MATERIAL			SURFACE	STANDARD PACKING IN BOXES OF 5 SETS	A MM	B MM	C MM	SCREW	APPROX. WEIGHT KG/SET
	STEEL	LEFT HAND	RIGHT HAND	ELECTROPLATED						
21194	1	7	8	21	1	12	40	157	4,0	0,28
21195	1	7	8	21	1	12	40	314	4,0	0,55

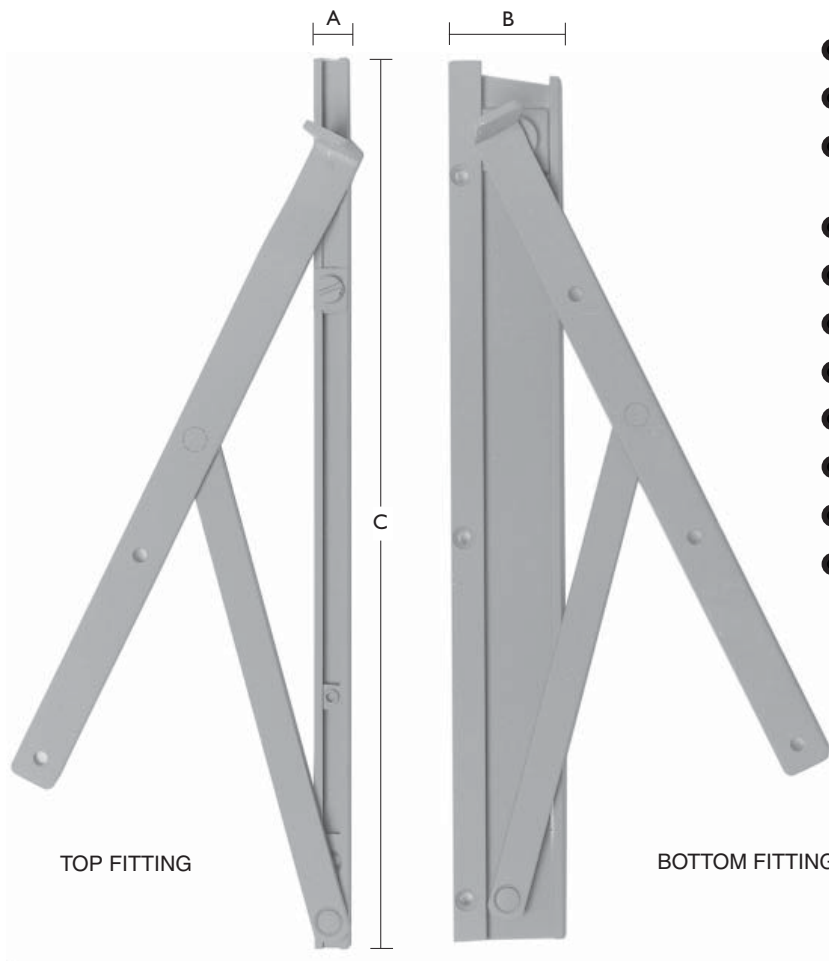

TOP FITTING

BOTTOM FITTING

1 SET

RIGHT HAND ILLUSTRATION

- CONVENIENT FOR CLEANING
- SWINGS 90°
- OPENS CLEAR FROM CURTAINS AND WINDOW FRAME
- MAX. VENTILATION
- EASY TO OPERATE
- EASY TO FIT
- CONCEALED FITTINGS
- FRICTION IN ALL POSITIONS
- ADJUSTABLE FRICTION
- ANODIZED ALUMINIUM RAILS
- ELECTROPLATED STEEL PARTS

FIRE-ESCAPE OPENING:
500 MM FROM MODULE 8
600 MM FROM MODULE 9



FITTING INSTRUCTIONS

IMPORTANT: WHEN MANUFACTURING THE WINDOW AND MOUNTING THE FITTINGS THE SLIDING SHOES NEED TO BE IN CENTER POSITION IN THE ALUMINIUM PROFILE, THIS ENABLES THE WOOD TO WORK. WHEN MOUNTING THE WINDOW THE TOP AND BOTTOM FRAME SHOULD BE PARALLEL. THIS IS NECESSARY, IN ORDER TO LET THE SLIDING SHOES GLIDE WITHOUT FRICTION IN THE ALUMINIUM PROFILE.

EXAMPLE WOOD PROFILE

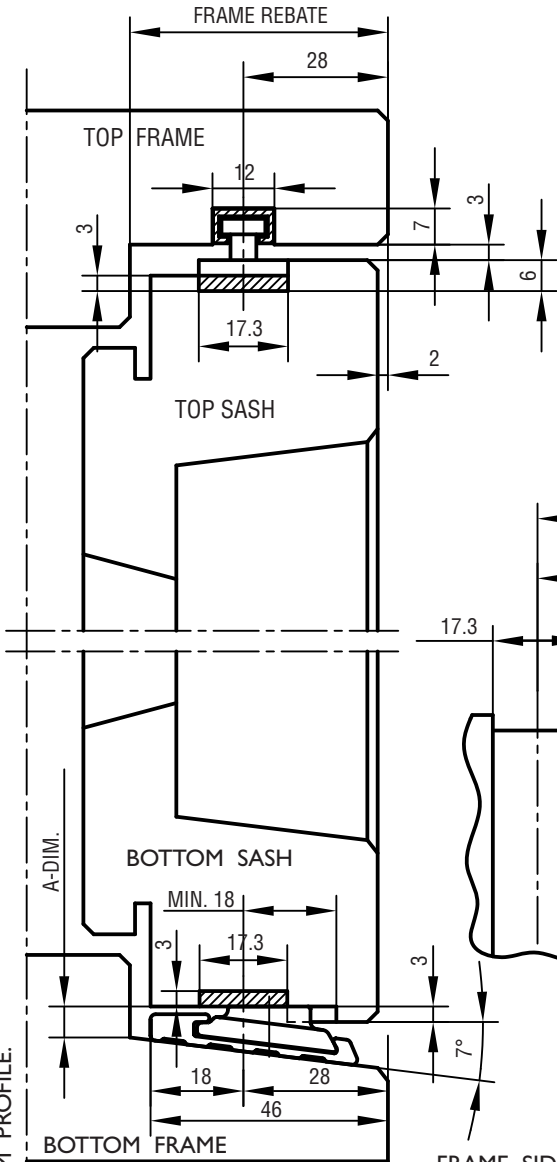

FIG. 1
VERTICAL PLAN

FRAME SIDE AND SASH SIDE NEED TO HAVE THE SAME PROFILE AS TOP FRAME AND TOP SASH.

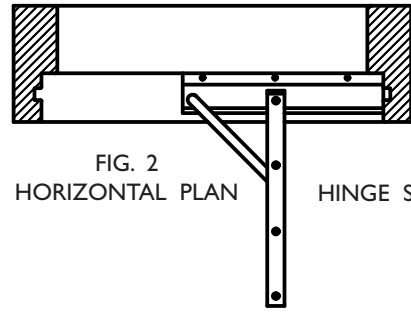

FIG. 2
HORIZONTAL PLAN HINGE SIDE

FITTING SHOWN ON FRAME CILL
RITHT HAND ILLUSTRATION

EXTRA CUT OUT IN SASH FROM UNDERNEATH. THE SLOT ROUTERED OUT MUST HAVE A WIDTH OF 22 X 9 MM AND A DEPTH OF 3 MM.

IPA NO.	21194	21195
MAX. WEIGHT OF SASH KGS	20	40
MIN. WIDTH OF SASH	150	320
MAX. WIDTH OF SASH	320	820
USE SCREW NO.	4.0	4.0

FIG. 3

FRAME REBATE	A-DIM.
46	6,5
50	6,0
54	5,5

FIG. 4

FITTING:

1. THE FITTING SHOULD BE POSITIONED IN THE GROOVES AT HEAD AND CILL OF FRAME AND SCREWED ON (FIGURE 1 AND 2)
2. NOW PUSH THE WINDOW SASH INTO POSITION BY SASH SLOTS AND FASTEN THE SCREWS.
3. NOW THE FRICTION CAN BE ADJUSTED BY MEANS OF THE NYLON SCREW ON THE TOP FITTING. IF A LARGER OPENING ANGEL IS WANTED THEN MOVE THE ADJUSTABLE STOP FITTING IN THE TOP FRAME ALUMINIUM RAIL.

MAINTENANCE:

THE FITTINGS ARE NOT TO BE PAINTED. TEST THE OPERATION FROM TIME TO TIME.WHEN FITTING - LUBRICATE THE PIVOT/MOVABLE METAL PARTS OF THE MECHANISM WHILE ACTIVATING REPEATEDLY. HEREAFTER LUBRICATE MINIMUM TWICE A YEAR. DO NOT LUBRICATE THE ALUMINIUM RAILS. SEE ALSO SECTION H.



FULLY REVERSIBLE FITTINGS

FOR SIDE SWING WINDOW 180°

IPA NO.s 21290-95

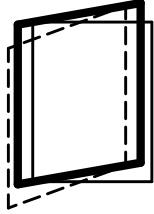

IPA NO.	ORDERING NO.		SURFACE		STANDARD PACKING IN BOXES OF 5 SETS	MODULE	A MM	FRAMEWIDTH MM	STEEL PARTS MM	SCREW	APPROX. WEIGHT KG/SET
	MATERIAL		LEFT HAND	RIGHT HAND							
	STEEL										
21290	1	7 8	21	1	3	342	260-387	13X4	3,5 & 4,0	0,50	
21291	1	7 8	21	1	4	442	388-487	13X4	3,5 & 4,0	0,62	
21292	1	7 8	21	1	5	542	488-587	13X4	3,5 & 4,0	0,74	
21293	1	7 8	21	1	6	642	588-687	13X4	3,5 & 4,0	0,86	
21294	1	7 8	21	1	7	742	688-787	13X4	3,5 & 4,0	0,98	
21295	1	7 8	21	1	8	842	788-887	13X4	3,5 & 4,0	1,10	

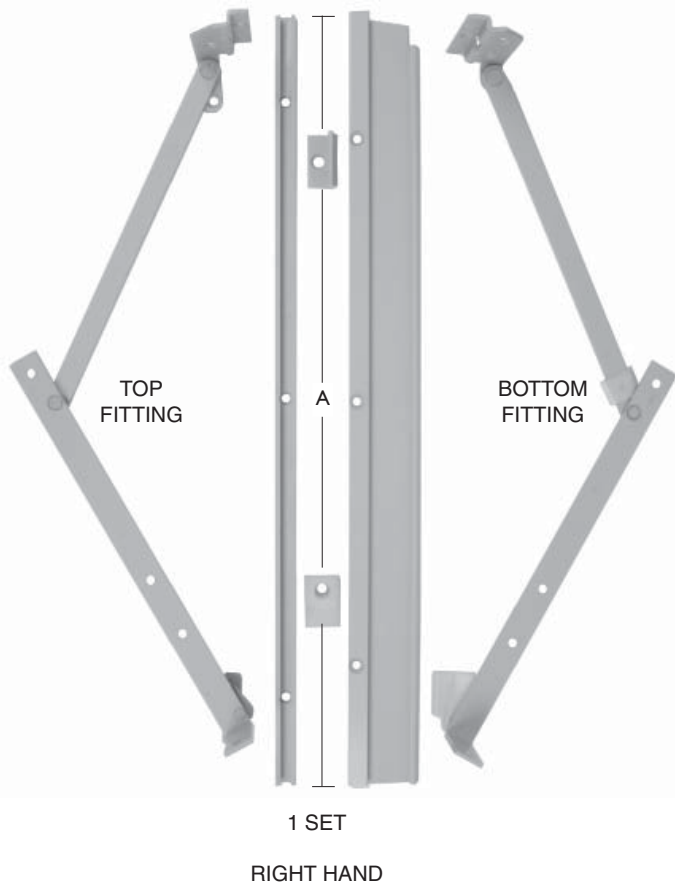

- CONVENIENT FOR CLEANING
- FULLY REVERSIBLE 180°
- OPENS CLEAR OF CURTAINS AND WINDOW FRAMES
- MAX. VENTILATION
- CONCEALED FITTINGS
- ANODIZED ALUMINIUM RAILS

FIRE-ESCAPE OPENING:
500 MM FROM MODULE 7
600 MM FROM MODULE 8



FITTING INSTRUCTIONS

WHEN FITTING/MOUNTING THE WINDOW IT IS NECESSARY THAT THE TOP AND BOTTOM FRAMES ARE STRAIGHT. THIS IS IMPERATIVE FOR THE SLIDES TO TRAVEL FREELY IN THEIR ALUMINIUM RAILS.

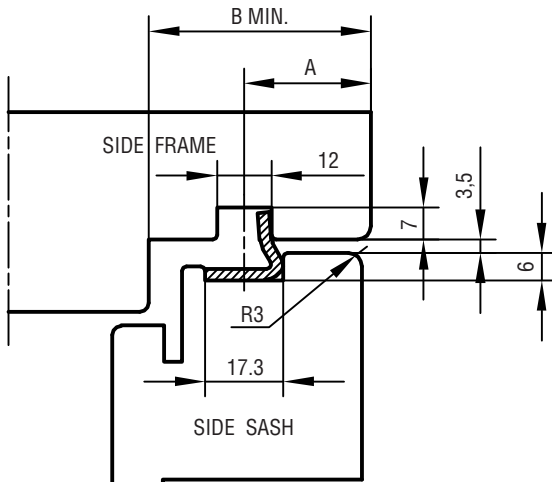

FIG. 2
SHOWN WITH SUPPORT FITTING
HORIZONTAL PLAN

FIG. 3

IPA NO.	*WIDTH		LENGTH MM	WEIGHT KG
	M	MM		
21290	3	204-331	342	40
21291	4	332-431	442	40
21292	5	432-531	542	40
21293	6	532-631	642	40
21294	7	632-731	742	40
21295	8	732-831	842	40

* SASH DIMENSIONS

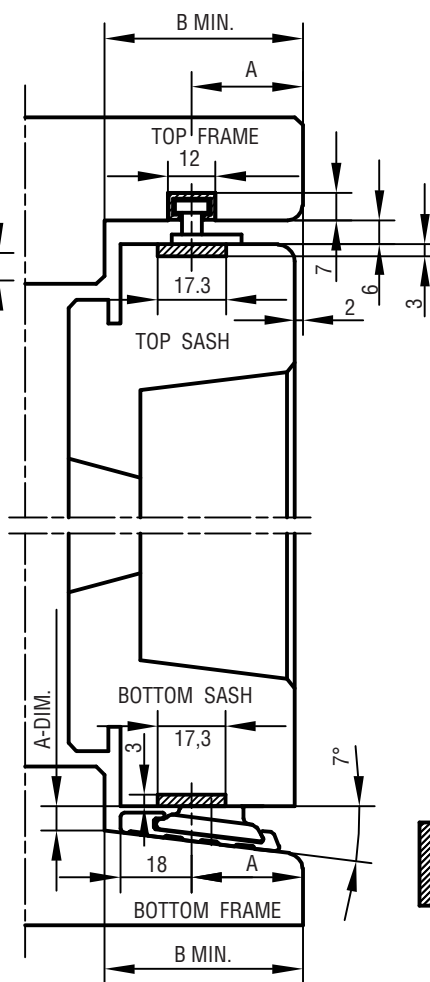

FIG. 1
VERTICAL PLAN

A	B MIN. MM
28.0	49.0
27.5	48.0
27.0	47.0
26.5	46.0

FIG. 4

THE DIMENSIONS INDICATED IN FIG. 4 MEAN THAT THE WEATHERSTRIP MUST BE MOUNTED ON THE SASH

FRAME REBATE	A-DIM. MM
46	6.5
50	6.0
54	5.5

FIG. 5

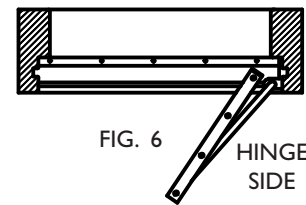

FIG. 6
FITTING SHOWN ON
BOTTOM CILL
RIGHT HAND ILLUSTRATION

FITTING:

1. CUT OFF THE ENDS OF ALUMINIUM RAILS - IF NECESSARY - CUT OFF MUST BE MADE IN THE END OPPOSITE THE HINGE SIDE.
2. ASSEMBLE SLIDE BARS AND SLIDE BLOCKS.
3. FIT THE ALUMINIUM RAILS INTO TOP AND BOTTOM FRAME SO THAT THE BOTTOM RAIL IS PLACED AGAINST THE FRAME ON THE HINGE SIDE. SHOWN IN FIG. 6. THEN MOUNT THE FRAME BRACKETS INTO GROOVES OF THE SIDE FRAMES AND FASTEN THE SCREWS.
4. INSERT SASH INTO POSITION OF THE STEERING KNUCKLE ARMS - GUIDED BY THE SASH GROOVE. FASTEN THE SCREWS.
5. FIT THE BEARING BLOCK (PLASTIC) INTO THE GROOVE OF THE BOTTOM SASH - APPROX. IN THE MIDDLE OF THE FREE PART OF THE GROOVE. FASTEN THE SCREW.
6. THE SUPPORT FITTING IS FITTED IN THE MIDDLE OF THE SIDE SASH IN THE HINGE SIDE. SEE FIG. 2.

MAINTENANCE:

THE FITTINGS ARE NOT TO BE PAINTED. TEST THE OPERATION FROM TIME TO TIME. WHEN FITTING - LUBRICATE THE PIVOT/MOVABLE METAL PARTS OF THE MECHANISM WHILE ACTIVATING REPEATEDLY. HEREAFTER LUBRICATE MINIMUM TWICE A YEAR. DO NOT LUBRICATE THE ALUMINIUM RAILS. SEE ALSO SECTION H.



FULLY REVERSIBLE FITTINGS

FOR SIDE SWING WINDOW 180°

IPA NO.s 21281-86

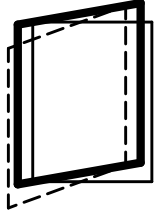

ORDERING NO.											
IPA NO.	MATERIAL		SURFACE		STANDARD PACKING IN BOXES OF 5 SETS	MODULE	A MM	FRAME WIDTH MM	STEEL PARTS MM	SCREW	APPROX. WEIGHT KG/SET
	STEEL	LEFT HAND	RIGHT HAND	ELECTROPLATED							
21281	1	7	8	21	1	3	342	260-387	13X4	3,5 & 4,0	0,50
21282	1	7	8	21	1	4	442	388-487	13X4	3,5 & 4,0	0,62
21283	1	7	8	21	1	5	542	488-587	13X4	3,5 & 4,0	0,74
21284	1	7	8	21	1	6	642	588-687	13X4	3,5 & 4,0	0,84
21285	1	7	8	21	1	7	742	688-787	13X4	3,5 & 4,0	0,98
21286	1	7	8	21	1	8	842	788-887	13X4	3,5 & 4,0	1,10

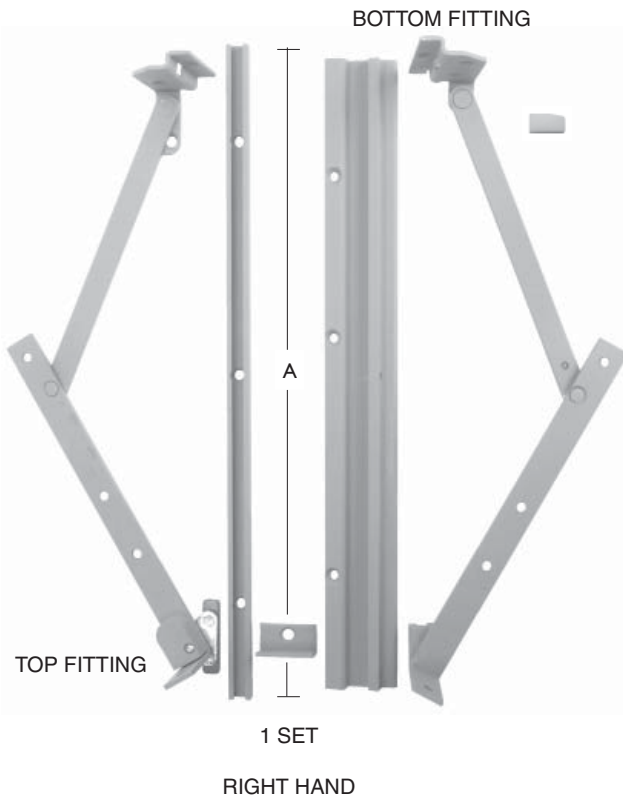

- CONVENIENT FOR CLEANING
- FULLY REVERSIBLE 180°
- OPENS CLEAR OF CURTAINS AND WINDOW FRAMES
- MAX. VENTILATION
- CONCEALED FITTINGS
- ANODIZED ALUMINIUM RAILS

FIRE-ESCAPE OPENING:
500 MM FROM MODULE 7
600 MM FROM MODULE 8



FITTING INSTRUCTIONS

IMPORTANT: WHEN FITTING/MOUNTING THE WINDOW IT IS NECESSARY THAT THE TOP AND BOTTOM FRAMES ARE STRAIGHT. THIS IS IMPERATIVE FOR THE SLIDES TO TRAVEL FREELY IN THEIR ALUMINIUM RAILS.

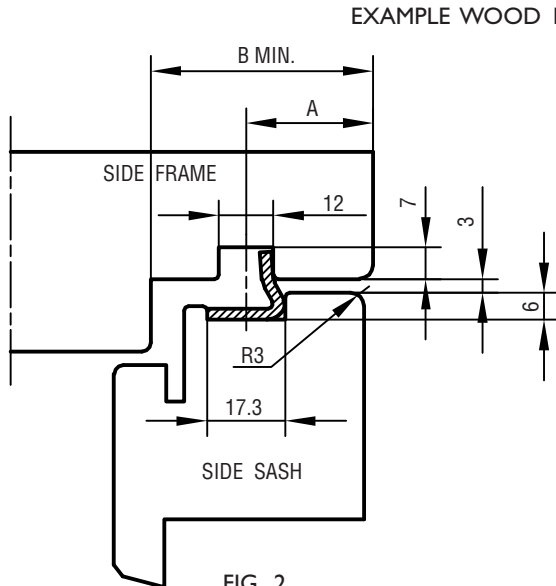

FIG. 2
SHOWN WITH SUPPORT FITTING
HORIZONTAL PLAN

IPA NO.	*WIDTH		LENGTH MM	WEIGHT KG
	M	MM		
21281	3	204-331	342	40
21282	4	332-431	442	40
21283	5	432-531	542	40
21284	6	532-631	642	40
21285	7	632-731	742	40
21286	8	732-831	842	40

* SASH DIMENSIONS

FITTING:

- CUT OFF THE ENDS OF ALUMINIUM RAILS - IF NECESSARY - CUT OFF MUST BE MADE IN THE END OPPOSITE THE HINGE SIDE.
- ASSEMBLE SLIDE BARS AND SLIDE BLOCKS.
- FIT THE ALUMINIUM RAILS INTO TOP AND BOTTOM FRAME SO THAT THE BOTTOM RAIL IS PLACED AGAINST THE FRAME ON THE HINGE SIDE. SHOWN IN FIG. 6. THEN MOUNT THE FRAME BRACKETS INTO GROOVES OF THE SIDE FRAMES AND FASTEN THE SCREWS.
- INSERT SASH INTO POSITION OF THE STEERING KNUCKLE ARMS - GUIDED BY THE SASH GROOVE. FASTEN THE SCREWS.
- FIT THE BEARING BLOCK (PLASTIC) INTO THE GROOVE OF THE BOTTOM SASH - OPPOSITE THE HINGE SIDE. FASTEN THE SCREW.
- THE SUPPORT FITTING IS FITTED IN THE MIDDLE OF THE SIDE SASH IN THE HINGE SIDE. SEE FIG. 2.

MAINTENANCE:

THE FITTINGS ARE NOT TO BE PAINTED. TEST THE OPERATION FROM TIME TO TIME. WHEN FITTING - LUBRICATE THE PIVOT/MOVABLE METAL PARTS OF THE MECHANISM WHILE ACTIVATING REPEATEDLY. HEREAFTER LUBRICATE MINIMUM TWICE A YEAR. DO NOT LUBRICATE THE ALUMINIUM RAILS. SEE ALSO SECTION H.

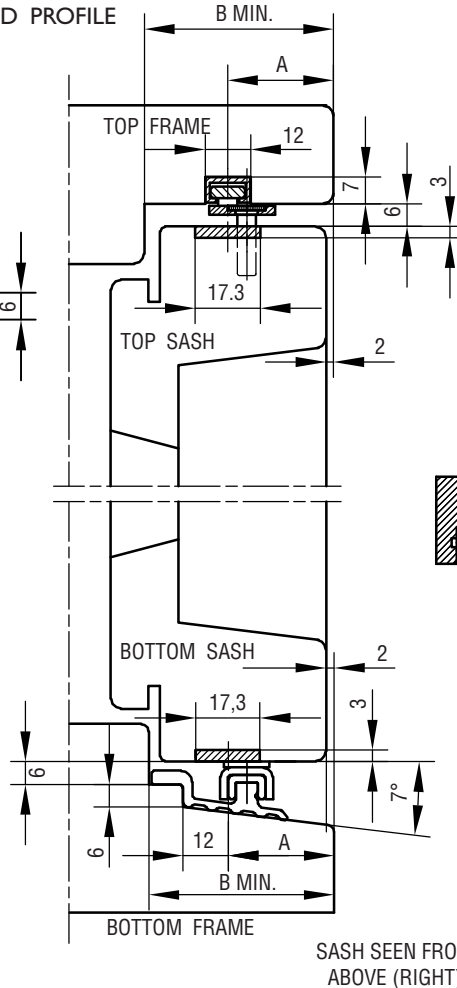

SASH SEEN FROM ABOVE (RIGHT)

A	B MIN.
28,0	49,0
27,5	48,0
26,0	47,0

FIG. 4

THE DIMENSIONS INDICATED IN FIG. 4 MEAN THAT THE WEATHERSTRIP MUST BE MOUNTED ON THE SASH

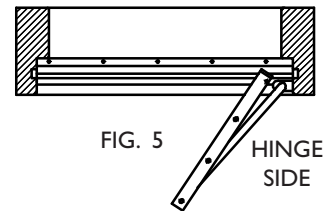

FIG. 5
HINGE SIDE

FITTING SHOWN ON BOTTOM CILL
RIGHT HAND ILLUSTRATION

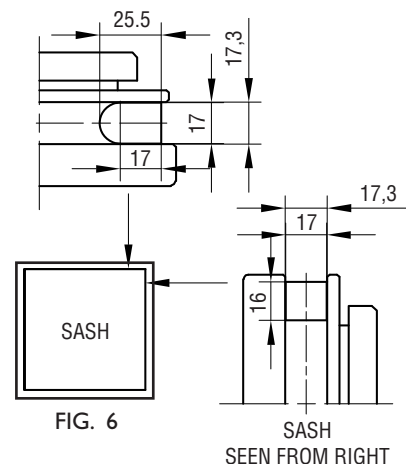

FIG. 6

SASH SEEN FROM RIGHT

CUT-OUT FOR FITTING ON HINGE SIDE OF TOP SASH



TOP HINGE

IPA NO. 21125

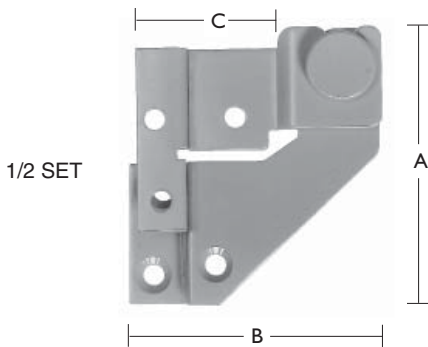
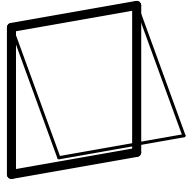

ORDERING NO.											
IPA NO.	MATERIAL		SURFACE			A MM	B MM	C MM	THICKNESS PLATE MM	SCREW	APPROX. WEIGHT KG / SET
	STEEL	WITHOUT SPECIFICATION	ELECTROPLATED YELLOW	GALVANIZED	STANDARD PACKING IN BOXES OF 10 SETS						
21125	1	0	25	87	1	68	62	40	2,5	4,0	0,16

FIRE-ESCAPE OPENING:
500 MM FROM MODULE 7
600 MM FROM MODULE 8



FITTING INSTRUCTIONS

EXAMPLE WOOD PROFILE

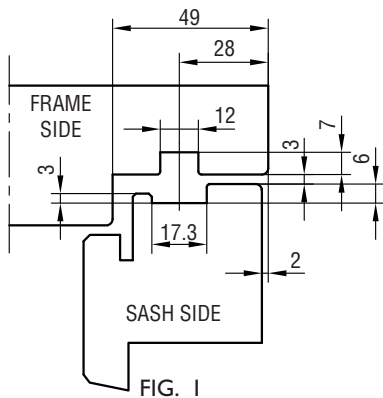

MAX. SASH WEIGHT: 40 KGS

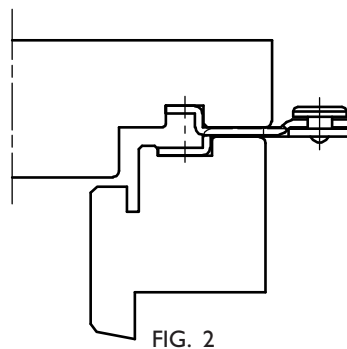

FITTINGS ON FRAME SIDE

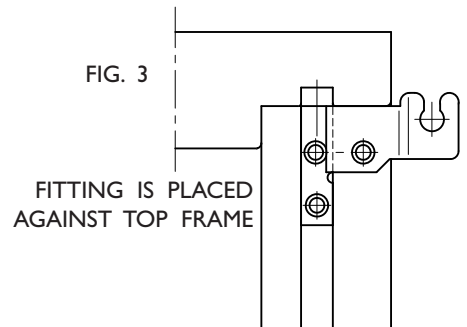

FITTING ON SASH SIDE

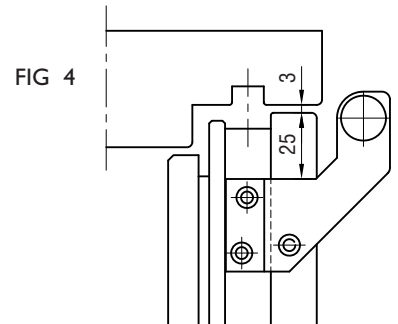

MAINTENANCE:
TEST THE OPERATION FROM TIME TO TIME.
WHEN FITTING - GREASE THE PIVOT/MOVABLE METAL PARTS OF THE MECHANISM WHILE ACTIVATING REPEATEDLY.
HEREAFTER GREASE MINIMUM TWICE A YEAR.
SEE ALSO SPECIAL CHAPTER ON THIS SUBJECT.



TOP HINGE

IPA NO. 21127-28

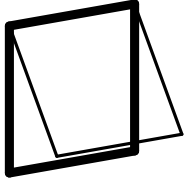

1/2 SET

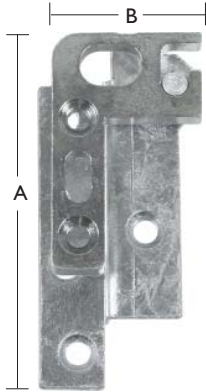

ORDERING NO.											
IPA NO.	MATERIAL	SURFACE				A MM	B MM	THICKNESS PLATE MM	SCREW	APPROX. WEIGHT KG / SET	
	STEEL	WITHOUT SPECIFICATION	ELECTROPLATED YELLOW	GALVANIZED	STANDARD PACKING IN BOXES OF 10 SETS						INDUSTRIAL PACKING IN BOXES OF 100 SETS
21127	1	0	25	87	1	-	79	36	2,5	4,0	0,17
21128	1	0	-	87	-	2	79	36	2,5	4,0	0,17

● CONCEALED FITTINGS



IPA NR. 21128
W/SECURITY PIN

FIRE-ESCAPE OPENING:
500 MM FROM MODULE 7
600 MM FROM MODULE 8



FITTING INSTRUCTIONS

EXAMPLE WOOD PROFILE

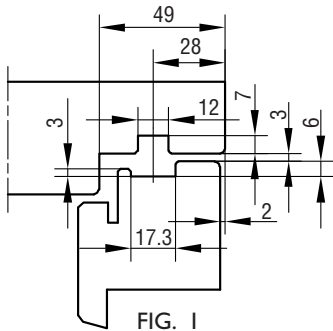

FIG. 1

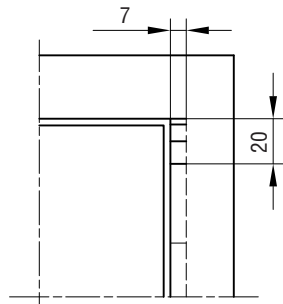
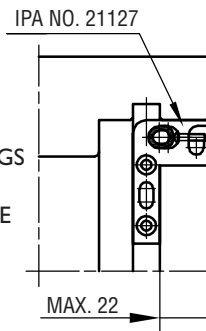
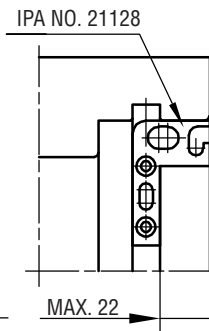

FIG. 3



MAX. 22



MAX. 22

FIG. 4

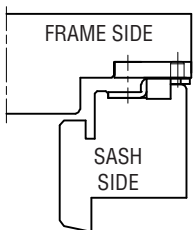

FIG. 2

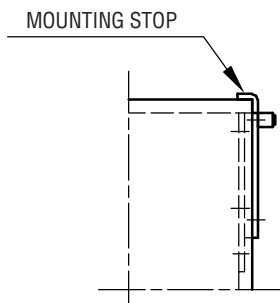

FIG. 5

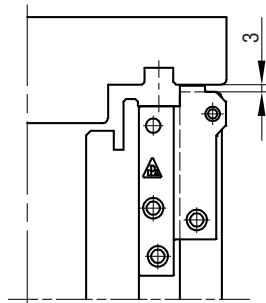

FIG. 6

MAX. SASH WEIGHT: 50 KGS

MAINTENANCE:
TEST THE OPERATION FROM TIME TO TIME. WHEN FITTING - GREASE THE PIVOT/ MOVABLE METAL PARTS OF THE MECHANISM WHILE ACTIVATING REPEATEDLY. HEREAFTER GREASE MINIMUM TWICE A YEAR. SEE ALSO SPECIAL CHAPTER ON THIS SUBJECT.



REVERSIBLE PROJECTING GEARS WITH DISPLACED TURNINGPOINT IPA NO.s 21044-52

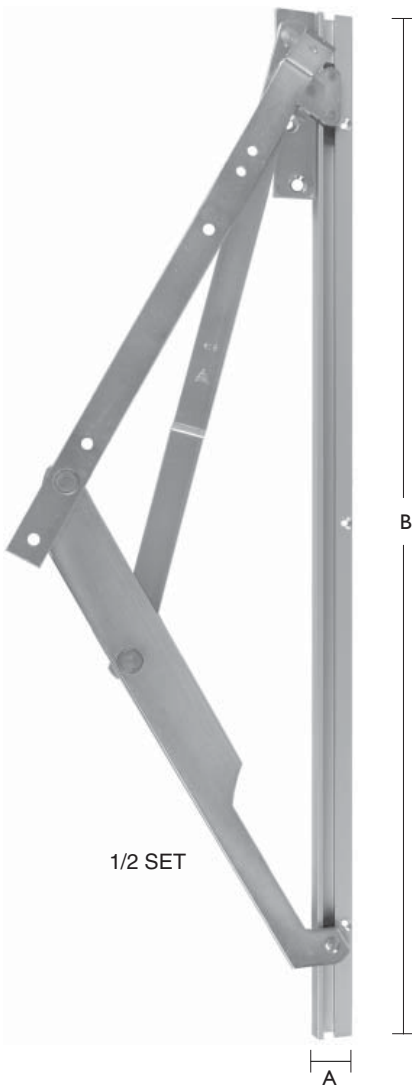
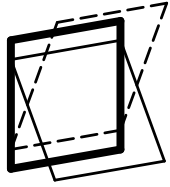

ORDERING NO.											
IPA NO.	MATERIAL		SURFACE		STANDARD PACKING IN BOXES OF 1 SET	MODULE	A MM	B MM	FRAME DIMENSION OUTSIDE MM	SCREW	APPROX. WEIGHT KG / SET
	STEEL	WITHOUT SPECIFICATION	ELECTROPLATED								
21044	1	0	21	1	1	6	18	513	588-687	3,5 & 4,0	1,1
21045	1	0	21	1	1	7	18	613	688-787	3,5 & 4,0	1,3
21046	1	0	21	1	1	8	18	713	788-887	3,5 & 4,0	1,5
21047	1	0	21	1	1	9	18	813	888-987	3,5 & 4,0	1,7
21048	1	0	21	1	1	10	18	913	988-1087	3,5 & 4,0	1,9
21049	1	0	21	1	1	11	18	1013	1088-1187	3,5 & 4,0	2,1
21050	1	0	21	1	1	12	18	1113	1188-1287	3,5 & 4,0	2,3
21051	1	0	21	1	1	13	18	1213	1288-1387	3,5 & 4,0	2,5
21052	1	0	21	1	1	14	18	1313	1388-1487	3,5 & 4,0	2,7

- CONCEALED FITTINGS
- FULLY REVERSIBLE 170°
- OPENS CLEAR OF CURTAINS AND WINDOW FRAME
- MUSHROOM HEAD ESPAGNOLETTE IPA NO.s 23051-70, ROLLER BOLT ESPAGNOLETTE IPA NO.s 23151-70 AND SIDE BOLT ESPAGNOLETTE IPA NO.s 23701-69 CAN BE USED
- ANODIZED RAILS

FIRE-ESCAPE OPENING:
500 MM FROM IPA NO. 21047
600 MM FROM IPA NO. 21049

RESTRICTORS, SEE SECTION D



FITTING INSTRUCTIONS

IMPORTANT: THE SIDE FRAMES MUST BE STRAIGHT TO THE EFFECT THAT THE DISTANCE BETWEEN THE SIDE FRAMES (SLIDING RAILS) IS EXACTLY THE SAME FOR ANY HEIGHT OF THE FRAME. THIS IS IMPERATIVE FOR THE SLIDES TO TRAVEL FREELY IN THEIR ALUMINIUM RAILS.

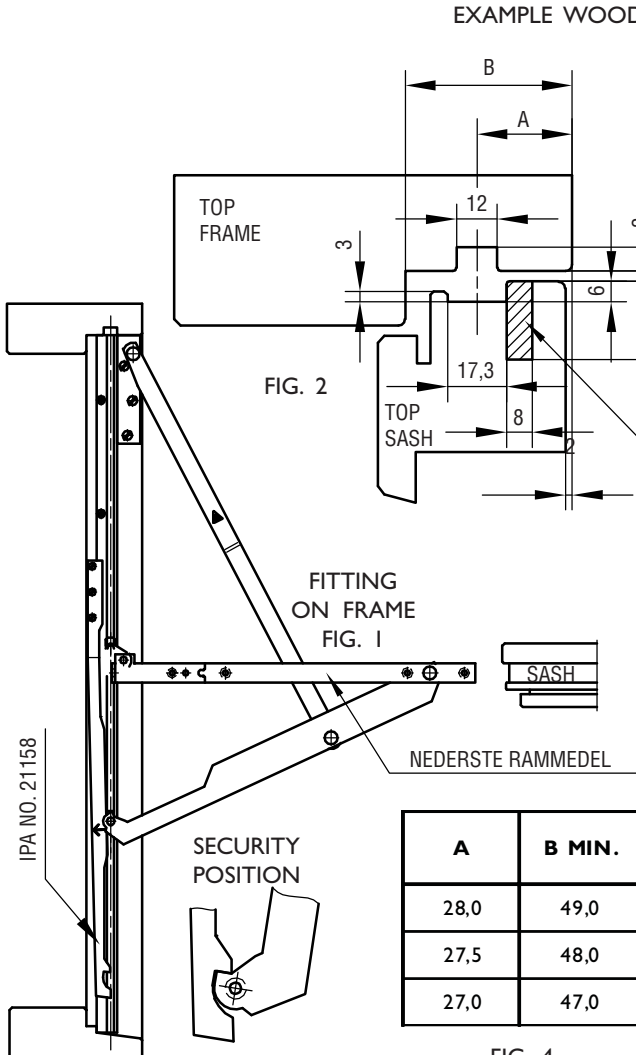

A	B MIN.
28,0	49,0
27,5	48,0
27,0	47,0

FIG. 4

THE DIMENSIONS INDICATED IN FIGURE 4 MEAN THAT THE WEATHERSTRIP MUST BE MOUNTED ON THE SASH

IPA NO.	MODULE	INSIDE FRAME MM	LENGTH OF FITTING	MAX. WEIGHT KGS.
21044	6	514-613	513	45
21045	7	614-713	613	45
21046	8	714-813	713	45
21047	9	814-913	813	45
21048	10	914-1013	913	60
21049	11	1014-1113	1013	60
21050	12	1114-1213	1113	60
21051	13	1214-1313	1213	60
21052	14	1314-1413	1313	60

USE THE LARGEST POSSIBLE FITTING

FITTING:

1. PLACE THE FITTING INTO BOTH SIDES OF THE FRAME.
2. POSITION FITTING AGAINST TOP FRAME. USE SCREWS NO. 3,5.
3. PLACE THE BEARING PLATE AGAINST THE TOP AND AGAINST THE ALUMINIUM RAIL. USE SCREWS NO. 4,0
4. INSERT THE SASH BETWEEN HINGE ARMS AND PUSH THE SASH AGAINST THE STOP BRACKET. FASTEN THE SASH WITH SCREWS NO. 4,0, STARTING WITH THE SCREW IN THE STOP BRACKET.
5. FIT THE RESTRICTOR IPA NO. 21158 ON THE LEFT SIDE - SEE FIG. 1.
6. FOR SECURITY REASONS. MAKE SURE THAT THE FIRST NOTCH IS ALWAYS USED IN CLEANING POSITION, SEE FIG. 5

OPERATION INSTRUCTIONS:

1. OPEN THE WINDOW - THE RESTRICTOR WILL AUTOMATICALLY RESTRICT THE WINDOW.
2. PULL THE SASH 20 MM - PRESS THE RESTRICTOR IN THE DIRECTION OF THE ARROW AND OPEN THE WINDOW, SEE FIG. 1.
3. WHEN THE WINDOW IS REVERSED FOR CLEANING, THE MECHANISM WILL LOCK AUTOMATICALLY. DISENGAGE AS MENTIONED IN POINT 2.

MAINTENANCE:

THE FITTINGS ARE NOT TO BE PAINTED. WHEN FITTING - LUBRICATE THE PIVOT/MOVABLE METAL PARTS OF THE MECHANISM WHILE ACTIVATING REPEATEDLY. HEREAFTER LUBRICATE MINIMUM TWICE A YEAR. DO NOT GREASE THE ALUMINIUM RAILS. TEST THE OPERATION FROM TIME TO TIME. SEE ALSO SECTION H ON THIS SUBJECT.



REVERSIBLE PROJECTING GEARS

IPA NO.s 21144-52

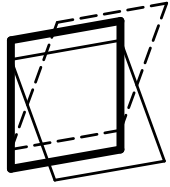

ORDERING NO.					MODULE	A MM	B MM	FRAME DIMENSION OUTSIDE MM	SCREW	APPROX. WEIGHT KG / SET
IPA NO.	MATERIAL	SURFACE		STANDARD PACKING IN BOXES OF 1 SET						
	STEEL	WITHOUT SPECIFICATION	ELECTROPLATED							
21144	1	0	21	1	6	18	513	588-687	3,5 & 4,0	1,1
21145	1	0	21	1	7	18	613	688-787	3,5 & 4,0	1,3
21146	1	0	21	1	8	18	713	788-887	3,5 & 4,0	1,5
21147	1	0	21	1	9	18	813	888-987	3,5 & 4,0	1,7
21148	1	0	21	1	10	18	913	988-1087	3,5 & 4,0	1,9
21149	1	0	21	1	11	18	1013	1088-1187	3,5 & 4,0	2,1
21150	1	0	21	1	12	18	1113	1188-1287	3,5 & 4,0	2,3
21151	1	0	21	1	13	18	1213	1288-1387	3,5 & 4,0	2,5
21152	1	0	21	1	14	18	1313	1388-1487	3,5 & 4,0	2,7

- CONCEALED FITTINGS
- FULLY REVERSIBLE 170°
- OPENS CLEAR OF CURTAINS AND WINDOW FRAME
- MUSHROOM HEAD ESPAGNOLETTE IPA NO.s 23051-70, ROLLER BOLT ESPAGNOLETTE IPA NO.s 23151-70 AND SIDE BOLT ESPAGNOLETTE IPA NO.s 23701-69 CAN BE USED
- ANODIZED RAILS

FIRE-ESCAPE OPENING:
500 MM FROM IPA NO. 21147
600 MM FROM IPA NO. 21149

RESTRICTORS: SEE SECTION D.



FITTING INSTRUCTIONS

FOR THE FITTING OF ANY WINDOW OF A SIZE LARGER THAN M 10 AT LEAST THREE FIXING POINTS (EXPANSION BOLTS) ARE REQUIRED FOR EACH SIDE FRAME. THE SIDE FRAMES MUST BE STRAIGHT TO THE EFFECT THAT THE DISTANCE BETWEEN THE SIDE FRAMES (SLIDING RAILS) IS EXACTLY THE SAME FOR ANY HEIGHT OF THE FRAME. THIS IS IMPERATIVE FOR THE SLIDES TO TRAVEL FREELY IN THEIR ALUMINIUM RAILS.

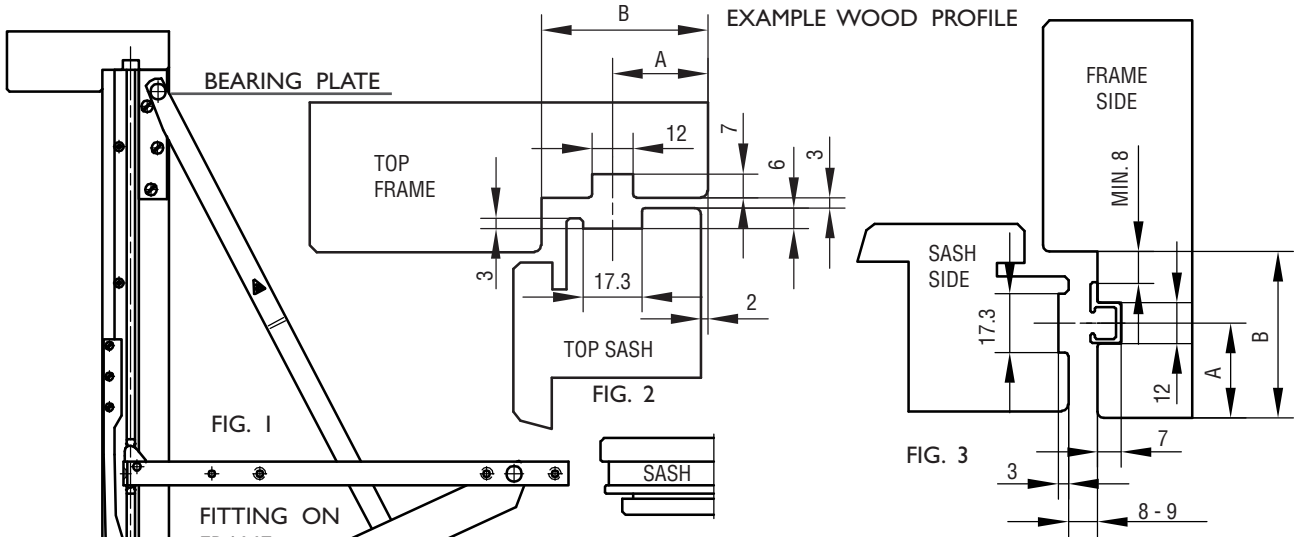

IPA NO. 21158

SECURITY POSITION

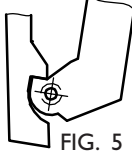

A	B MIN.
28,0	49,0
27,5	48,0
27,0	47,0

FIG. 4

THE DIMENSIONS INDICATED IN FIGURE 4 MEAN THAT THE WEATHERSTRIP MUST BE MOUNTED ON THE SASH

IPA NO.	MODULE	INSIDE FRAME MM	LENGTH OF FITTING	MAX. WEIGHT KGS.
21144	6	514-613	513	45
21145	7	614-713	613	45
21146	8	714-813	713	45
21147	9	814-913	813	45
21148	10	914-1013	913	60
21149	11	1014-1113	1013	60
21150	12	1114-1213	1113	60
21151	13	1214-1313	1213	60
21152	14	1314-1413	1313	60

USE THE LARGEST POSSIBLE FITTING

FITTING:

1. PLACE THE FITTING INTO BOTH SIDES OF THE FRAME.
2. POSITION FITTING AGAINST TOP FRAME. USE SCREWS NO. 3,5.
3. PLACE THE BEARING PLATE AGAINST THE TOP AND AGAINST THE ALUMINIUM RAIL. USE SCREWS NO. 4,0
4. INSERT THE SASH BETWEEN HINGE ARMS AND PUSH THE SASH AGAINST THE STOP BRACKET. FASTEN THE SASH WITH SCREWS NO. 4,0, STARTING WITH THE SCREW IN THE STOP BRACKET.

5. FIT THE RESTRICTOR IPA NO. 21158 ON THE LEFT SIDE - SEE FIG. 1.
6. FOR SECURITY REASONS. MAKE SURE THAT THE FIRST NOTCH IS ALWAYS USED IN CLEANING POSITION, SEE FIG. 5

OPERATION INSTRUCTIONS:

1. OPEN THE WINDOW - THE RESTRICTOR WILL AUTOMATICALLY RESTRICT THE WINDOW.
2. PULL THE SASH 20MM - PRESS THE RESTRICTOR IN THE DIRECTION OF THE ARROW AND OPEN THE WINDOW, SEE FIG. 1.
3. WHEN THE WINDOW IS REVERSED FOR CLEANING, THE MECHANISM WILL LOCK AUTOMATICALLY. DISENGAGE AS MENTIONED IN POINT 2.

MAINTENANCE:

THE FITTINGS ARE NOT TO BE PAINTED. WHEN FITTING - LUBRICATE THE PIVOT/MOVABLE METAL PARTS OF THE MECHANISM WHILE ACTIVATING REPEATEDLY. HEREAFTER LUBRICATE MINIMUM TWICE A YEAR. DO NOT GREASE THE ALUMINIUM RAILS. TEST THE OPERATION FROM TIME TO TIME. SEE ALSO SECTION H ON THIS SUBJECT.

IMPORTANT:



CANOPY STAYS

WITH ADJUSTABLE FRICTION

IPA NO.s 21167-68 & 88

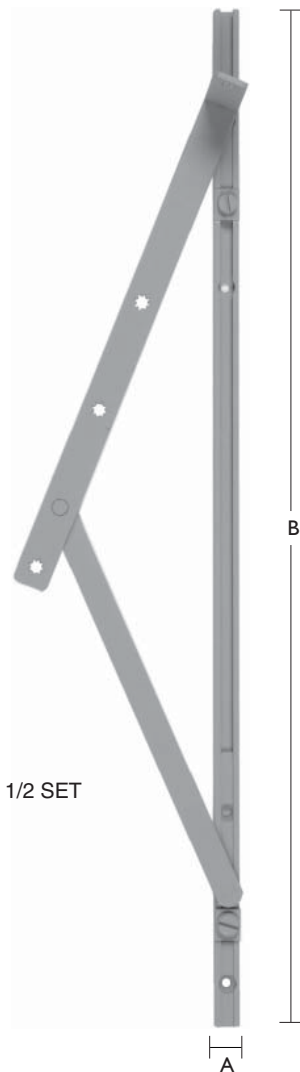
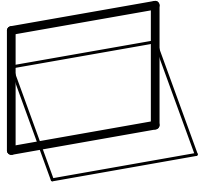

IPA NO.	ORDERING NO.				A MM	B MM	SCREW	APPROX. WEIGHT KG / SET	
	MATERIAL	SURFACE		STANDARD PACKING IN BOXES OF 5 SETS					
	STEEL	WITHOUT SPECIFICATION	ELECTROPLATED						
21167	1	0	21	1	-	12	473	4,0	0,55
21168	1	0	21	1	-	12	486	4,0	0,59
21188	1	0	21	-	2	12	504	4,0	0,65

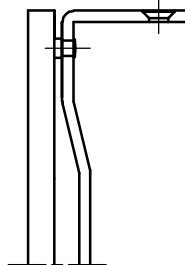

21167

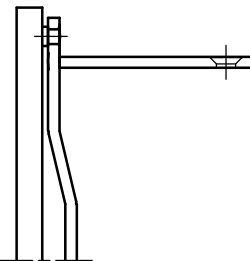

21168 + 88

- CONCEALED FITTINGS
- ADJUSTABLE FRICTION
- FRICTION IN ALL POSITIONS
- ANODIZED ALUMINIUM RAILS
- IPA NO. 21188 IS VERTICALLY ADJUSTABLE ± 1.5 MM
- EASY TO MOUNT



← IPA NO. 21188

FIRE-ESCAPE OPENING:
500 MM FROM MODULE 7
600 MM FROM MODULE 8



FITTING INSTRUCTIONS

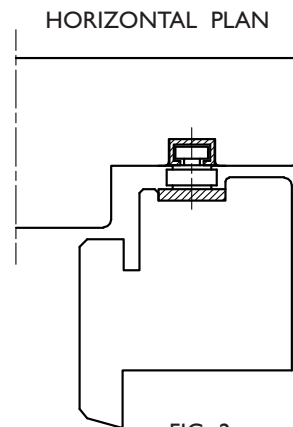
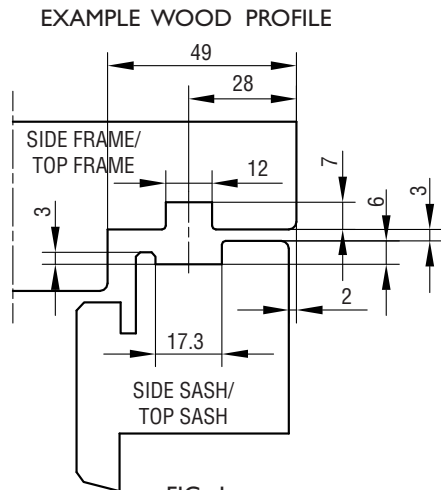

FITTING:

- 21167: SIDE SASH & -FRAME ARE MADE WITH THROUGH-GOING GROOVES, SEE FIGURE 1.
21168+88: SIDE SASH & - FRAME AND TOP SASH & - FRAME ARE MADE WITH THROUGH-GOING GROOVES, SEE FIGURE 1.

- CLOSE THE FITTING AND PLACE IT IN THE GROOVE OF THE SIDE FRAME.

21167: PLACE THE FITTING AGAINST THE TOP FRAME.

21168+88: PLACE THE FITTING AGAINST THE BOTTOM OF THE REBATE IN THE TOP FRAME.

PLACE AND FASTEN THE SCREW IN THE BOTTOM HOLE OF THE FITTING. OPEN THE FITTING AND FASTEN THE REMAINING SCREWS.

- PUSH THE SASH INTO ITS PLACE BY INSERTING IT BETWEEN THE FITTINGS, GUIDED BY THE GROOVES IN THE SASH, TILL THE SASH HITS THE STOPS OF THE FITTING. THESE STOPS WILL GUARANTEE A 3 MM GAB BETWEEN FRAME AND SASH.

21167: IF THE TOP SASH IS MADE WITH GROOVE, FIG. 1, FIRST PLACE THE SMALL MOUNTING BRACKETS IN EACH SIDE UNDER TOP BRACKET OF THE FITTING BEFORE FASTEN THE SCREWS.

- NOW THE FRICTION MAY BE ADJUSTED BY MEANS OF THE NYLON SCREWS IN THE SLIDES. BEFORE ADJUSTMENT, PRESS THE SLIDING PART DOWN TO THE STOPS. THE BEST RESULT FOR THE WINDOW MOVEMENT IS ACHIEVED BY EQUAL FRICTION AT EITHER SIDE.

- 21188: THE SASH CAN BE ADJUSTED ± 1.5 MM UP OR DOWN. BEFORE ANY ADJUSTMENT THE MOUNTING SCREWS IN THE BOTTOM IN EACH SIDE OF THE FRAME HAVE TO BE LOOSENED. THEN ADJUST BY USING A TORX20 KEY TO TURN THE ECCENTRIC SCREW. BY DELIVERY THE MARK ON THE ECCENTRIC SCREW IS IN A VERTICAL POSITION INDICATING THE O-POSITION. WHEN THE MARK IS IN HORIZONTAL POSITION IN EITHER TOP OR BOTTOM, THE FITTING IS ADJUSTED TO IT'S MAX OF ± 1.5 MM. AFTER THE ADJUSTMENT THE MOUNTING SCREWS IN THE BOTTOM OF EACH SIDE ARE FASTENED.

IPA NO.	21167	21168	21188
MAX. WEIGHT OF SASH KG	70	70	70
MAX. HEIGHT OF SASH MM	1400	1400	1400
USE SCREW NO.	4,0	4,0	4,0

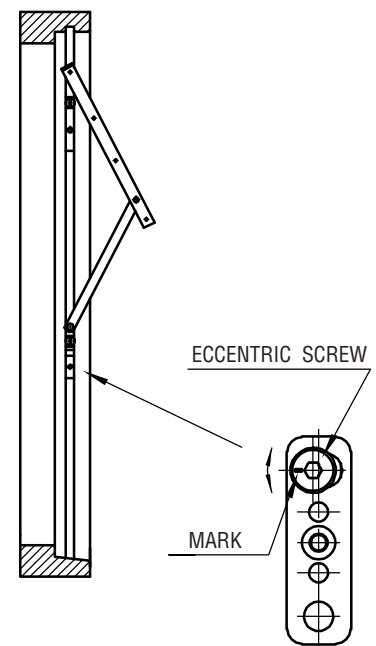

IPA NO. 21188

FIG. 3

MAINTENANCE:

THE FITTINGS ARE NOT TO BE PAINTED. TEST THE OPERATION FROM TIME TO TIME. WHEN FITTING - LUBRICATE THE PIVOT/MOVABLE METAL PARTS OF THE MECHANISM WHILE ACTIVATING REPEATEDLY. HEREAFTER LUBRICATE MINIMUM TWICE A YEAR. DO NOT LUBRICATE THE ALUMINIUM RAILS. SEE ALSO SPECIAL CHAPTER ON THIS SUBJECT.



CANOPY STAYS WITH ADJUSTABLE FRICTION IPA NO.s 21170-82

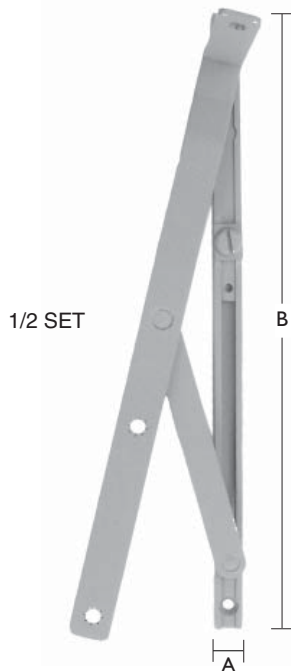
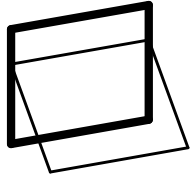

ORDERING NO.								
IPA NO.	MATERIAL	WITHOUT SPECIFICATION	SURFACE	STANDARD PACKING IN BOXES OF 5 SETS	A MM	B MM	SCREW	APPROX. WEHGT KG / SET
	STEEL		ELECTROPLATED					
21170	1	0	21	1	12	263	4,0	0,46
21173	1	0	21	1	12	453	4,0	0,60
21174	1	0	21	1	12	711	4,0	0,78
21175	1	0	21	1	12	160	4,0	0,27
21179	1	0	21	1	12	250	4,0	0,40
21182	1	0	21	1	12	440	4,0	0,50

- CONCEALED FITTINGS
- ADJUSTABLE FRICTION
- FRICTION IN ALL POSITIONS
- ANODIZED ALUMINIUM RAILS
- BY REDUCING THE OPENING ANGLE, THE SASH LOAD CAN BE INCREASED ON IPA NO. 21174 (SEE FITTING INSTRUCTION ON THE NEXT PAGE)

OBS! BY REDUCING THE OPENING ANGLE THE FIRE-ESCAPE OPENING IS ALSO REDUCED

FIRE-ESCAPE OPENING:

IPA NO. 21179
500 MM FROM MODULE 8
600 MM FROM MODULE 9

IPA NO. 21170
500 MM FROM MODULE 9
600 MM FROM MODULE 10

IPA NO. 21173 & 21182
500 MM FROM MODULE 10
600 MM FROM MODULE 11

IPA NO. 21174
500 MM FROM MODULE 12
600 MM FROM MODULE 14

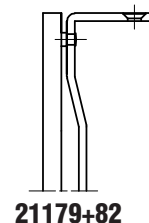
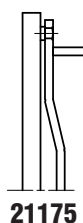
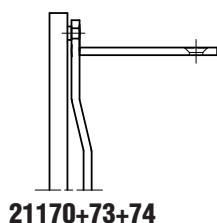



FITTING INSTRUCTIONS

EXAMPLE WOOD PROFILE

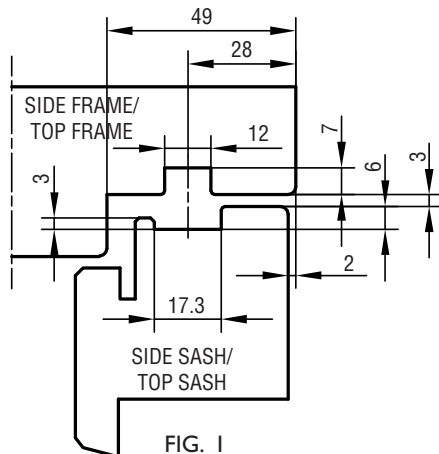

FIG. 1

HORIZONTAL PLAN

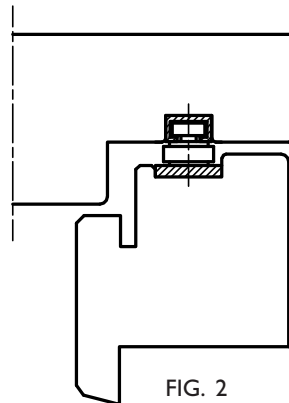

FIG. 2

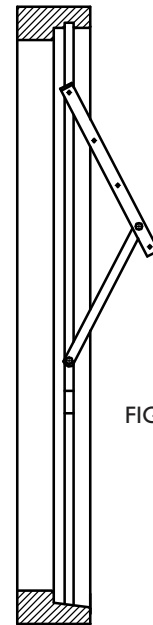

FIG. 3

IPA NO.	21170 & 79	21173 & 82	21174	21175
MAX. WEIGHT OF SASH KGS	40	50	70	20
MAX. HEIGHT OF SASH MM	900	1400	1600	350
USE SCREW NO.	4,0	4,0	4,0	4,0

FITTING:

- 21170-75: SIDE SASH & - FRAME AND TOP SASH & -FRAME ARE MADE WITH THROUGH-GOING GROOVES, SEE FIGURE 1.

21179-82: SIDE SASH & - FRAME ARE MADE WITH THROUGH-GOING GROOVES, SEE FIGURE 1.
- CLOSE THE FITTING AND PLACE IT IN THE GROOVE OF THE SIDE FRAME.

21170-75: PLACE THE FITTING AGAINST THE BOTTOM OF THE GROOVE IN THE TOP FRAME.

21179-82: PLACE THE FITTING AGAINST THE TOP FRAME.

PLACE AND FASTEN THE SCREW IN THE BOTTOM HOLE OF THE FITTING. OPEN THE FITTING AND FASTEN THE REMAINING SCREWS.

21173: MOUNT THE STOP PLATE THROUGH THE TOP SCREW HOLE IN THE STOP PLATE IN ORDER TO OBTAIN THE LARGEST FIRE-ESCAPE OPENING. **IF THE BOTTOM SCREW HOLE IS USED THEN THE FITTING WILL CARRY A MAX. SASH WEIGHT OF 60 KGS., BUT THE FIRE-ESCAPE OPENING WILL BE REDUCED.**

21174: MOUNT THE STOP PLATE THROUGH THE TOP SCREW HOLE UNDER THE FRICTION ELEMENT TO OBTAIN MAXIMUM FIRE-ESCAPE OPENING. **IF ONE OF THE OTHER SCREW HOLES ARE USED THEN THE FIRE-ESCAPE OPENING WILL BE REDUCED, BUT THE MAX. SASH WEIGHT WILL THEN BE: CENTER HOLE: 85 KGS - BOTTOM HOLE: 100 KGS.**
- PUSH THE SASH INTO ITS PLACE BY INSERTING IT BETWEEN THE FITTINGS, GUIDED BY THE GROOVES IN THE SASH, TILL THE SASH HITS THE STOPS OF THE FITTING. THESE STOPS WILL GUARANTEE A 3 MM GAB BETWEEN FRAME AND SASH. FASTEN THE SCREWS, BEGINNING WITH THE ONES IN THE TOP BRACKETS (IPA NOS 21170-74, 21179 & 21182)

21179-82: IF THE TOP SASH IS MADE WITH GROOVE, FIG. 1, FIRST PLACE THE SMALL MOUNTING BRACKETS IN EACH SIDE UNDER TOP BRACKET OF THE FITTING BEFORE FASTEN THE SCREWS.
- NOW THE FRICTION MAY BE ADJUSTED BY MEANS OF THE NYLON SCREWS IN THE SLIDING ELEMENTS. THE BEST RESULT FOR THE WINDOW MOVEMENT IS ACHIEVED BY EQUAL FRICTION AT EITHER SIDE.

MAINTENANCE:

THE FITTINGS ARE NOT TO BE PAINTED. TEST THE OPERATION FROM TIME TO TIME. WHEN FITTING - LUBRICATE THE PIVOT/MOVABLE METAL PARTS OF THE MECHANISM WHILE ACTIVATING REPEATEDLY. HEREAFTER LUBRICATE MINIMUM TWICE A YEAR. DO NOT LUBRICATE THE ALUMINIUM RAILS. SEE ALSO SPECIAL CHAPTER ON THIS SUBJECT.



REVERSIBLE PROJECTING GEARS

IPA NO.s 21874-82 W/ADJUSTABLE FRICTION

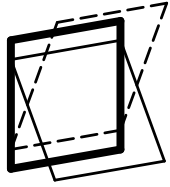

1/2 SET

ADJUSTABLE FRICTION



IPA NO.	ORDERING NO.				A MM	B MM	FRAME DIMENSION INSIDE MM	SCREW	APPROX. WEIGHT KG / SET
	MATERIAL	SURFACE		STANDARD PACKING IN BOXES OF 1 SET					
	STEEL	WITHOUT SPECIFICATION	ELECTROPLATED						
21874	1	0	21	1	18	534	535-634	3,5 & 4,0	1,1
21875	1	0	21	1	18	634	635-734	3,5 & 4,0	1,3
21876	1	0	21	1	18	734	735-834	3,5 & 4,0	1,5
21877	1	0	21	1	18	834	835-934	3,5 & 4,0	1,7
21878	1	0	21	1	18	934	935-1034	3,5 & 4,0	1,9
21879	1	0	21	1	18	1034	1035-1134	3,5 & 4,0	2,1
21880	1	0	21	1	18	1134	1135-1234	3,5 & 4,0	2,3
21881	1	0	21	1	18	1234	1235-1334	3,5 & 4,0	2,5
21882	1	0	21	1	18	1334	1335-1434	3,5 & 4,0	2,7

- ADJUSTABLE FRICTION
- CONCEALED FITTINGS
- FULLY REVERSIBLE 170°
- OPENS CLEAR OF CURTAINS AND WINDOW FRAME
- MUSHROOM HEAD ESPAGNOLETTE IPA NO.s 23051-70, ROLLER BOLT ESPAGNOLETTE IPA NO.s 23151-70 AND SIDE BOLT ESPAGNOLETTE IPA NO.s 23701-69 CAN BE USED
- ANODIZED RAILS

FIRE-ESCAPE OPENING:
500 MM FROM IPA NO. 21877
600 MM FROM IPA NO. 21879

RESTRICTORS: SEE CHAPTER D.



FITTING INSTRUCTIONS

IMPORTANT: FOR THE FITTING OF ANY WINDOW OF A SIZE LARGER THAN M 10 AT LEAST THREE FIXING POINTS (EXPANSION BOLTS) ARE REQUIRED FOR EACH SIDE FRAME. THE SIDE FRAMES MUST BE STRAIGHT TO THE EFFECT THAT THE DISTANCE BETWEEN THE SIDE FRAMES (SLIDING RAILS) IS EXACTLY THE SAME FOR ANY HEIGHT OF THE FRAME. THIS IS IMPERATIVE FOR THE SLIDES TO TRAVEL FREELY IN THEIR ALUMINIUM RAILS.

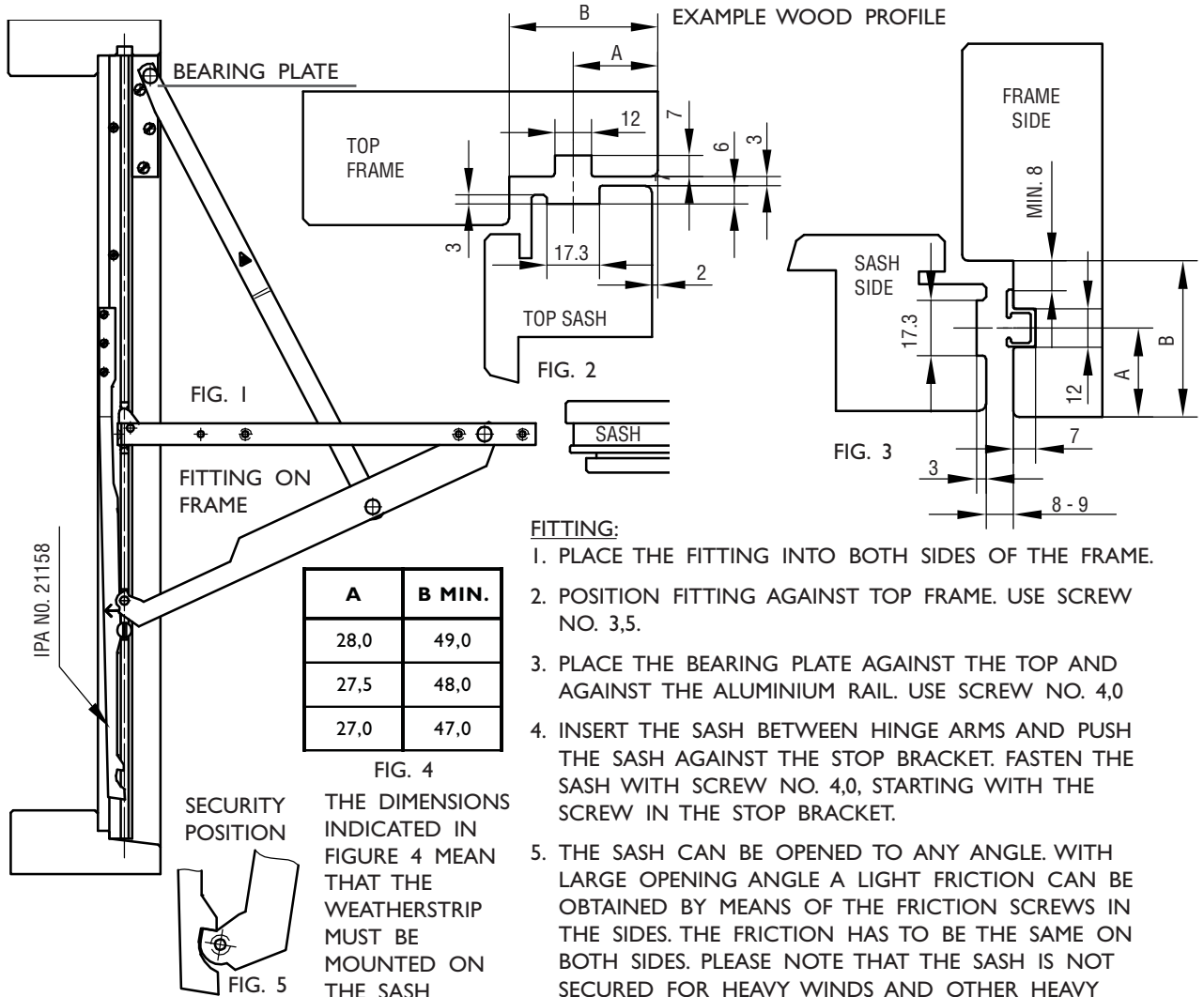

IPA NO.	INSIDE FRAME MM	LENGTH OF FITTINGS	MAX. WEIGHT KGS.
21874	535-634	534	45
21875	635-734	634	45
21876	735-834	734	45
21877	835-934	834	45
21878	935-1034	934	60
21879	1035-1134	1034	60
21880	1135-1234	1134	60
21881	1235-1334	1234	60
21882	1335-1434	1334	60

USE THE LARGEST POSSIBLE FITTING

FITTING:

1. PLACE THE FITTING INTO BOTH SIDES OF THE FRAME.
2. POSITION FITTING AGAINST TOP FRAME. USE SCREW NO. 3,5.
3. PLACE THE BEARING PLATE AGAINST THE TOP AND AGAINST THE ALUMINIUM RAIL. USE SCREW NO. 4,0
4. INSERT THE SASH BETWEEN HINGE ARMS AND PUSH THE SASH AGAINST THE STOP BRACKET. FASTEN THE SASH WITH SCREW NO. 4,0, STARTING WITH THE SCREW IN THE STOP BRACKET.
5. THE SASH CAN BE OPENED TO ANY ANGLE. WITH LARGE OPENING ANGLE A LIGHT FRICTION CAN BE OBTAINED BY MEANS OF THE FRICTION SCREWS IN THE SIDES. THE FRICTION HAS TO BE THE SAME ON BOTH SIDES. PLEASE NOTE THAT THE SASH IS NOT SECURED FOR HEAVY WINDS AND OTHER HEAVY INFLUENCE.
6. FIT THE RESTRICTOR IPA NO. 21158 ON THE LEFT SIDE. USE SCREW NO. 3.5. - SEE FIG. 1.
7. FOR SECURITY REASONS. MAKE SURE THAT THE TOP NOTCH IS ALWAYS USED IN CLEANING POSITION SEE FIG 5. BOTTOM NOTCH IS FOR LIMITED OPENING POSITION

OPERATION INSTRUCTIONS:

1. OPEN THE WINDOW - THE RESTRICTOR WILL AUTOMATICALLY RESTRICT THE WINDOW.
2. PULL THE SASH 20 MM - PRESS THE RESTRICTOR IN THE DIRECTION OF THE ARROW AND OPEN THE WINDOW - SEE FIG. 1.
3. WHEN THE WINDOW IS REVERSED FOR CLEANING, THE MECHANISM WILL LOCK AUTOMATICALLY. DISENGAGE AS MENTIONED IN POINT 2.

MAINTENANCE:

THE FITTINGS ARE NOT TO BE PAINTED. WHEN FITTING - LUBRICATE THE PIVOT/MOVABLE METAL PARTS OF THE MECHANISM WHILE ACTIVATING REPEATEDLY. HEREAFTER LUBRICATE MINIMUM TWICE A YEAR. DO NOT GREASE THE ALUMINIUM RAILS. TEST THE OPERATION FROM TIME TO TIME. SEE ALSO SECTION H ON THIS SUBJECT.



ADJUSTABLE CANOPY STAYS WITH ADJUSTABLE FRICTION IPA NO.s 21186-87 & 89

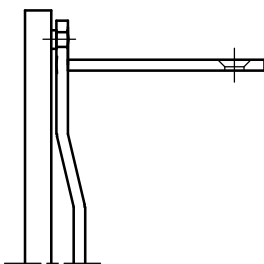
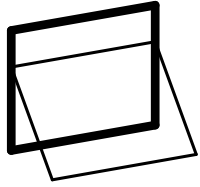

21186-87 + 21189

ORDERING NO.								
IPA NO.	MATERIAL		SURFACE		A MM	B MM	SCREW	APPROX. WEIHT KG / SET
	STEEL	WITHOUT SPECIFICATION	ELECTROPLATED	STANDARDPACKING IN BOXES OF 5 SETS				
21186	1	0	21	2	12	298	4,0	0,46
21187	1	0	21	2	12	488	4,0	0,60
21189	1	0	21	2	12	746	4,0	0,78

- CONCEALED FITTINGS
- ADJUSTABLE FRICTION
- FRICTION IN ALL POSITIONS
- ANODIZED ALUMINIUM RAILS
- VERTICALLY ADJUSTABLE ± 1.5 MM
- EASY TO MOUNT
- MAXIMUM SEALING
- **BY REDUCING THE OPENING ANGLE, THE SASH LOAD CAN BE INCREASED ON IPA NO. 21189 (SEE FITTING INSTRUCTION ON THE NEXT PAGE)**

OBS! BY REDUCING THE OPENING ANGLE THE FIRE-ESCAPE OPENING IS ALSO REDUCED

FIRE-ESCAPE OPENING: IPA NO. 21186
500 MM FROM MODULE 9
600 MM FROM MODULE 10

FIRE-ESCAPE OPENING: IPA NO. 21187
500 MM FROM MODULE 10
600 MM FROM MODULE 11

FIRE-ESCAPE OPENING: IPA NO. 21189
500 MM FROM MODULE 12
600 MM FROM MODULE 14



FITTING INSTRUCTIONS

EXAMPLE WOOD PROFILE

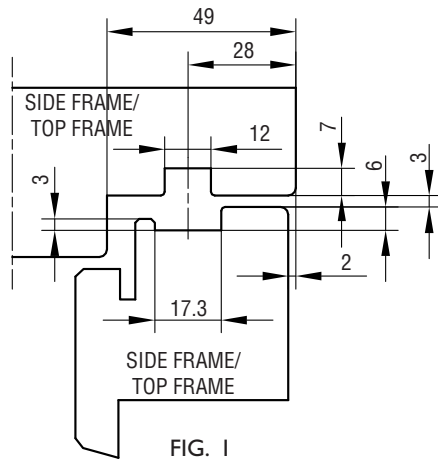

FIG. 1

HORIZONTAL PLAN

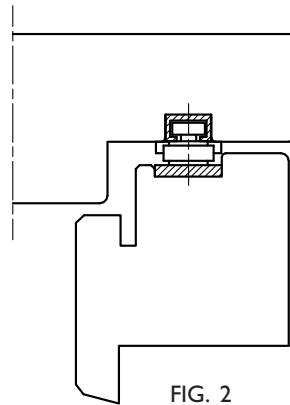
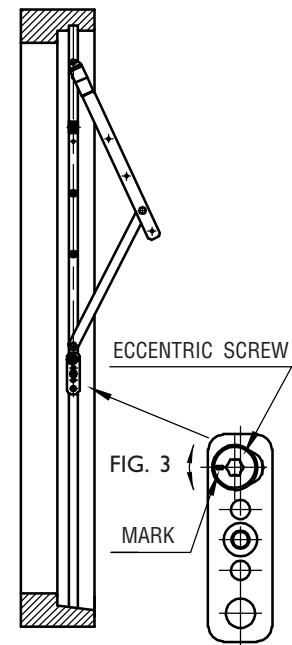

FIG. 2



IPA NO.	21186	21187	21189
MAX. WEIGHT OF SASH KG	40	50	70
MAX. HEIGHT OF FRAME MM	900	1400	1600
USE SCREW NO.	4,0	4,0	4,0

FITTING:

- SIDE SASH & -FRAME AND TOP SASH & -FRAME ARE MADE WITH THROUGH-GOING GROOVES, SEE FIGURE 1.
- CLOSE THE FITTING AND PLACE IT IN THE GROOVE OF THE SIDE FRAME. PLACE THE FITTING UP AGAINST THE BOTTOM OF THE GROOVE IN THE TOP FRAME. FASTEN THE SCREW BELOW, OPEN THE FITTING AND FASTEN THE REMAINING SCREWS.
 - 21187: FASTEN THE STOPPLATE PLACED IN THE ALUMINIUM RAIL BY USING A SCREW IN THE TOP SCREW HOLE FOR MAXIMUM FIRE-ESCAPE OPENING. IF THE BOTTOM SCREWHOLE IS USED THEN THE FITTING WILL CARRY A MAX. SASH WEIGHT OF 60 KGS., BUT THE FIRE-ESCAPE OPENING WILL BE REDUCED.
 - 21189: FASTEN THE STOPPLATE PLACED IN THE ALUMINIUM RAIL BY USING A SCREW IN THE TOP SCREW HOLE FOR MAXIMUM FIRE-ESCAPE OPENING. IF ONE OF THE OTHER SCREWHOLE ARE USED THEN THE FIRE-ESCAPE OPENING WILL BE REDUCED, BUT THE MAX. SASH WEIGHT WILL THEN BE:
 CENTER HOLE: 85 KGS - BOTTOM HOLE: 100 KGS.
- PUSH THE SASH INTO ITS PLACE BY INSERTING IT BETWEEN THE FITTINGS, GUIDED BY THE GROOVES IN THE SASH, TILL THE SASH HITS THE STOPS OF THE FITTING. THESE STOPS WILL GUARANTEE A 3 MM GAB BETWEEN FRAME AND SASH. FASTEN THE SCREWS, STARTING WITH THE ONES IN THE TOP BRACKETS.
- NOW THE FRICTION MAY BE ADJUSTED BY MEANS OF THE SCREWS IN THE SLIDES. BEFORE ADJUSTMENT, PRESS THE SLIDING PART DOWN TO THE STOPS. THE BEST RESULT FOR THE WINDOW MOVEMENT IS ACHIEVED BY EQUAL FRICTION AT EITHER SIDE.
- THE SASH CAN BE ADJUSTED ± 1.5 MM UP OR DOWN. BEFORE ANY ADJUSTMENT THE MOUNTING SCREWS IN THE BOTTOM IN EACH SIDE OF THE FRAME HAVE TO BE LOOSENED. THEN ADJUST BY USING A TORX20 KEY TO TURN THE ECCENTRIC SCREW. BY DELIVERY THE MARK ON THE ECCENTRIC SCREW IS IN A VERTICAL POSITION INDICATING THE 0-POSITION. WHEN THE MARK IS IN HORIZONTAL POSITION IN EITHER TOP OR BOTTOM, THE FITTING IS ADJUSTED TO IT'S MAX OF ± 1.5 MM. AFTER THE ADJUSTMENT THE MOUNTINGSCREWS IN THE BOTTOM OF EACH SIDE ARE FASTENED.

MAINTENANCE:

THE FITTINGS ARE NOT TO BE PAINTED. TEST THE OPERATION FROM TIME TO TIME. WHEN FITTING - LUBRICATE THE PIVOT/MOVABLE METAL PARTS OF THE MECHANISM WHILE ACTIVATING REPEATEDLY. HEREAFTER LUBRICATE MINIMUM TWICE A YEAR. DO NOT LUBRICATE THE ALUMINIUM RAILS. SEE ALSO SPECIAL CHAPTER ON THIS SUBJECT.



SAFETY RESTRICTOR

IPA NO. 21160

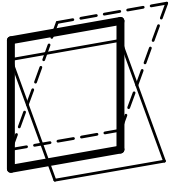

ORDERING NO.										
IPA NO.	MATERIAL	LEFT	SURFACE	STANDARD PACKING IN BOXES OF 10 PIECES	A MM	B MM	C MM	D MM	SCREW	APPROX. WEIGHT KG/EACH
	STEEL		ELECTROPLATED							
21160	1	7	21	1	50	34	30	60	3,5 & 4,0	0,12

USED IN CONJUNCTION WITH REVERSIBLE PROJECTING GEAR IPA NO.S 21144-52 AND IPA NO.s 21874-82

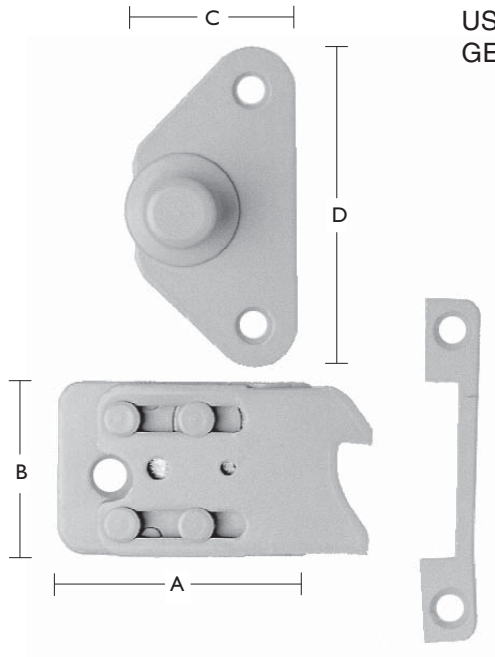



FITTING INSTRUCTIONS

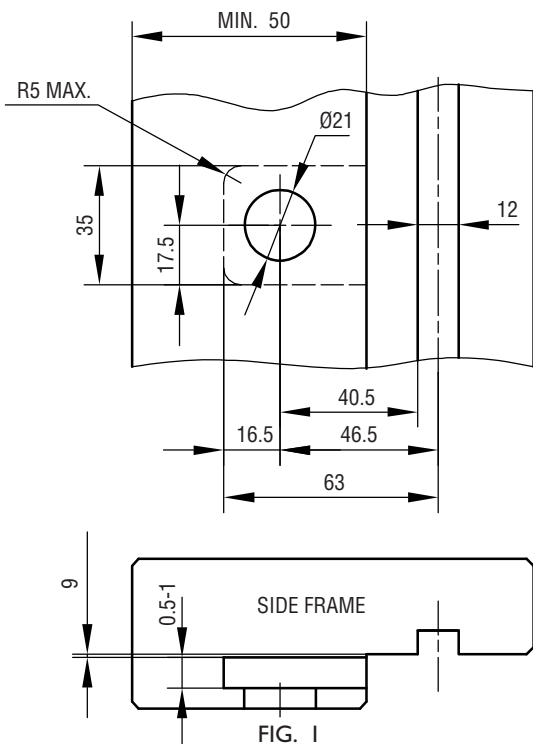

EXAMPLE WOOD PROFILE - SEE FIG. 1.

MOUNTING:

1. PLACE THE SAFETY CATCH INTO THE CUT OUT, HOLD AGAINST THE EDGE OF THE ALUMINIUM CHANNEL. THEN FASTEN WITH A NO. 4 SCREW RIGHT THROUGH THE 21 MM HOLE.
2. PLACE THE COVER PLATE OVER THE CUT OUT AND THE VISIBLE PART OF THE SAFETY CATCH, FASTEN WITH TWO NO. 3.5 SCREWS.
3. PLACE THE RESTRICTOR KNOB OVER THE 21 MM HOLE. THE PIN ON THE BACKSIDE OF THE OPERATING HANDLE MUST BE MOUNTED IN THE HOLE (4 MM) ON THE SAFETY CATCH. PUSH THE FRONT PLATE AWAY FROM THE WINDOW SO THAT THE RESTRICTOR KNOB HAS THE MAXIMUM POSSIBLE MOVEMENT - FASTEN THE TWO NO. 3.5 SCREWS ON THE FRONT PLATE.

4. CONTROL OF FUNCTION:

THE RESTRICTOR KNOB MUST HAVE A MOVEMENT OF APPROXIMATELY 7 MM AND BE ABLE TO RETURN BY ITSELF. THE SAFETY CATCH MUST FOLLOW THE MOVEMENT OF THE RESTRICTOR KNOB.

OPERATING INSTRUCTIONS:

1. OPEN THE SASH UNTIL THE SAFETY CATCH ENGAGES.
2. PULL IN THE SASH APPROXIMATELY 20 MM. DRAW THE RESTRICTOR KNOB DIRECTLY TOWARDS YOU, AND OPEN SASH.
3. THE SASH STOPS AUTOMATICALLY IN THE CLEANING POSITION. TO RELEASE THE SASH FOLLOW PROCEDURE AS GIVEN IN POINTS 1 AND 2.

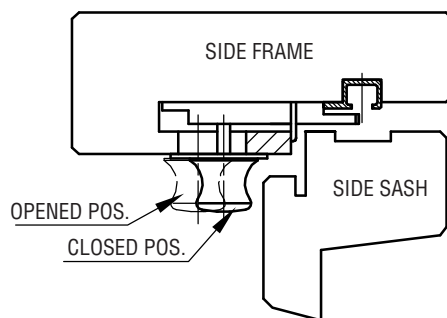
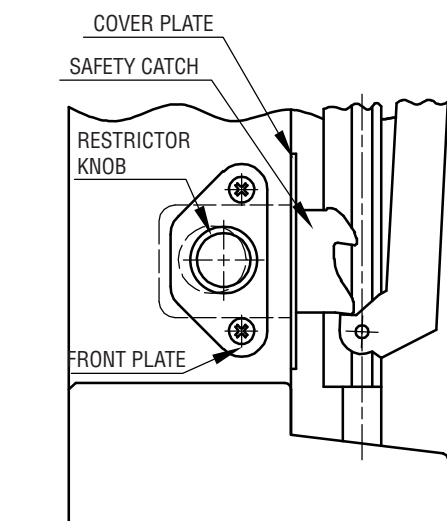

FIG. 2

MAINTENANCE:

THE FITTINGS ARE NOT TO BE PAINTED. TEST THE OPERATION FROM TIME TO TIME. WHEN FITTING - LUBRICATE THE PIVOT/ MOVABLE METAL PARTS OF THE MECHANISM WHILE ACTIVATING REPEATEDLY. HEREAFTER LUBRICATE MINIMUM TWICE A YEAR. DO NOT LUBRICATE THE ALUMINIUM RAILS. SEE ALSO SECTION H.



SUPPORT RAIL

IPA NO. 21227

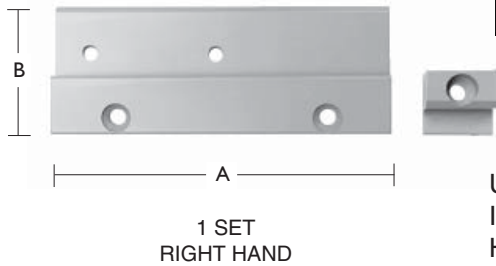
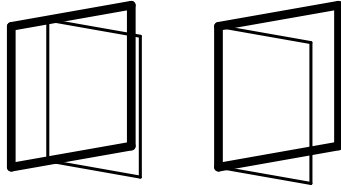

IPA NO.	MATERIAL	ORDERING NO.		SURFACE	STANDARD PACKING IN BOXES OF 5 SETS	A MM	B MM	SCREW	APPROX. WEIGHT KG / SET
	ALUMINIUM/PLASTIC	LEFT	RIGHT	ANODIZED					
21227	0	7	8	00	1	95	35,5	4,0	0,03

USED IN CONJUNCTION WITH SAFETY RESTRICTOR
 IPA NO. 21228 AND:
 HINGES IPA NO. 11173-74 & 77
 SIDE SWING WINDOW 90° WIHT FRICTION IPA NO.
 21193



SAFETY RESTRICTOR

IPA NO. 21228

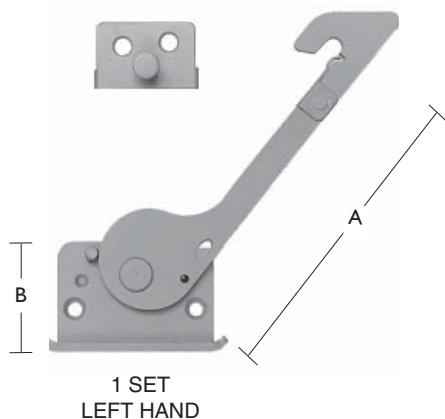
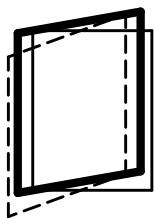

IPA NO.	MATERIAL	ORDERING NO.		SURFACE	STANDARD PACKING IN BOXES OF 5 SETS	A MM	B MM	SCREW	APPROX. WEIGHT KG / SET
	STEEL	LEFT	RIGHT	ELECTROPLATED					
21228	1	7	8	21	1	92	31,5	4,0	0,07



FITTING INSTRUCTIONS

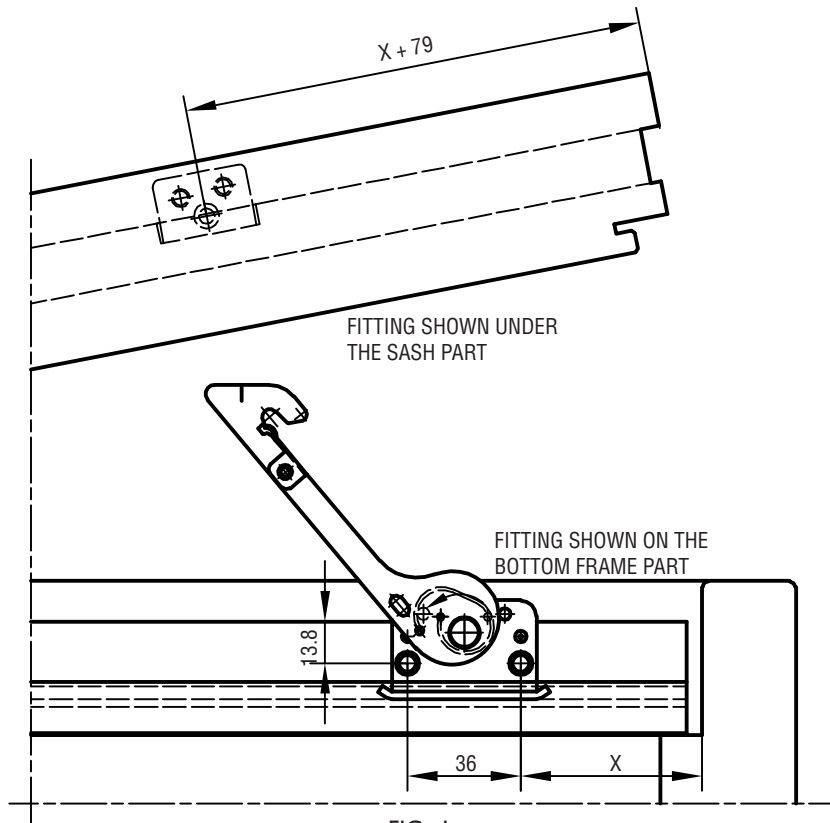
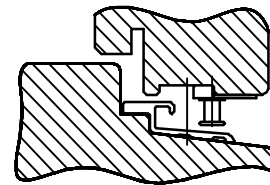

FIG. 1
RIGHT HAND ILLUSTRATION

X-DIMENSION IS OPTIONAL. WE SUGGEST 25 MM AS MINIMUM. BY USING LARGER X-DIMENSION THE VENTILATION OPENING WILL BE EXTENDED. AT THE SAME TIME THE TURNING OF SASH TO CLEANING POSITION WILL BE REDUCED AS THE RESTRICTOR WILL STOP THE SLIDING PART.

IMPORTANT: THE PIVOT CATCH OF THE RESTRICTOR IS FITTED IN THE BOTTOM CHANNEL OF THE SASH. USE THE MARK SHOWN ON THE RESTRICTOR ARM AS LOCATION POINT FOR THE PIVOT CATCH.



WHEN USING THE RESTRICTOR FOR SIDE HUNG LIFT-OFF WINDOWS MOUNT THE RESTRICTOR ON THE SUPPORT RAIL IPA NO. 21227. FIT THE BEARING BLOCK (PLASTIC) INTO THE IPA GROOVE IN THE BOTTOM CHANNEL OF THE SASH OVER THE FREE PART OF THE SUPPORT PLATE - OPPOSITE THE HINGE SIDE.

OPERATING INSTRUCTIONS:

1. OPEN THE SASH UNTIL THE RESTRICTOR CATCH ENGAGES.
2. PULL THE SASH IN APPROXIMATELY 20 MM.
3. PRESS THE RESTRICTOR ARM IN THE DIRECTION OF THE ARROW AND OPEN THE SASH.
4. WHEN THE WINDOW IS CLOSED THE RESTRICTOR RE-ENGAGES AUTOMATICALLY.

USE SCREW NO. 4.0

MAINTENANCE:

THE FITTINGS ARE NOT TO BE PAINTED. TEST THE OPERATION FROM TIME TO TIME. WHEN FITTING - LUBRICATE THE PIVOT/MOVABLE METAL PARTS OF THE MECHANISM WHILE ACTIVATING REPEATEDLY. HEREAFTER LUBRICATE MINIMUM TWICE A YEAR. DO NOT LUBRICATE THE ALUMINIUM RAILS. SEE ALSO SECTION H.

EXAMPLE WOOD PROFILE

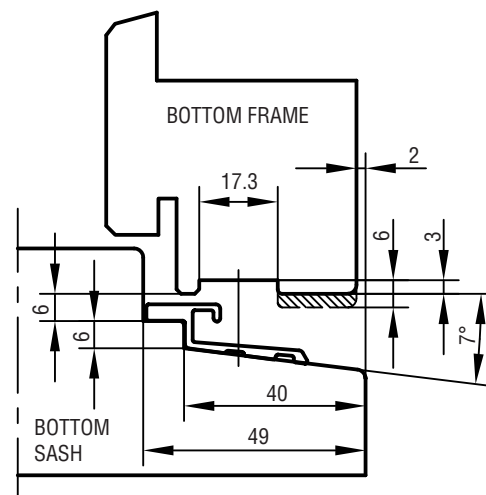
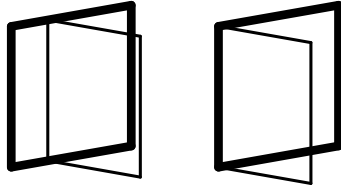

FIG. 2



SUPPORT RAIL

IPA NO. 21229



1 SET
RIGHT HAND

ORDERING NO.									
IPA NO.	MATERIAL			SURFACE	STANDARD PACKING IN BOXES OF 5 SETS	A MM	B MM	SCREW	APPROX. WEIGHT KG / SET
	ALUMINIUM/PLASTIC	LEFT	RIGHT	ANODIZED					
21229	0	7	8	00	1	90	40	4,0	0,03

USED IN CONJUNCTION WITH SAFETY RESTRICTOR
IPA NO. 21230 AND:
HINGES IPA NO. 11173-74 & 77
SIDE SWING WINDOW 90° WITH FRICTION IPA NO.
21195



SAFETY RESTRICTOR

IPA NO. 21230

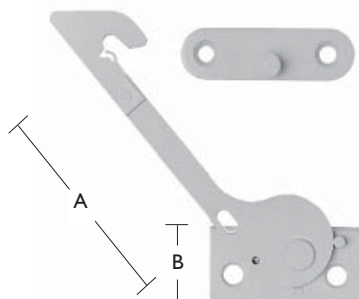
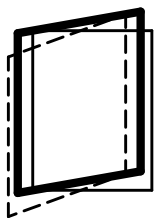

1 SET
RIGHT HAND

ORDERING NO.									
IPA NO.	MATERIAL			SURFACE	STANDARD PACKING IN BOXES OF 5 SETS	A MM	B MM	SCREW	APPROX. WEIGHT KG / SET
	STEEL	LEFT	RIGHT	ELECTROPLATED					
21230	1	7	8	21	1	92	25	4,0	0,06

USED IN CONJUNCTION WITH FULLY REVERSIBLE
FITTINGS FOR SIDE SWING WINDOW 180° IPA NO.
21290-95



FITTING INSTRUCTIONS

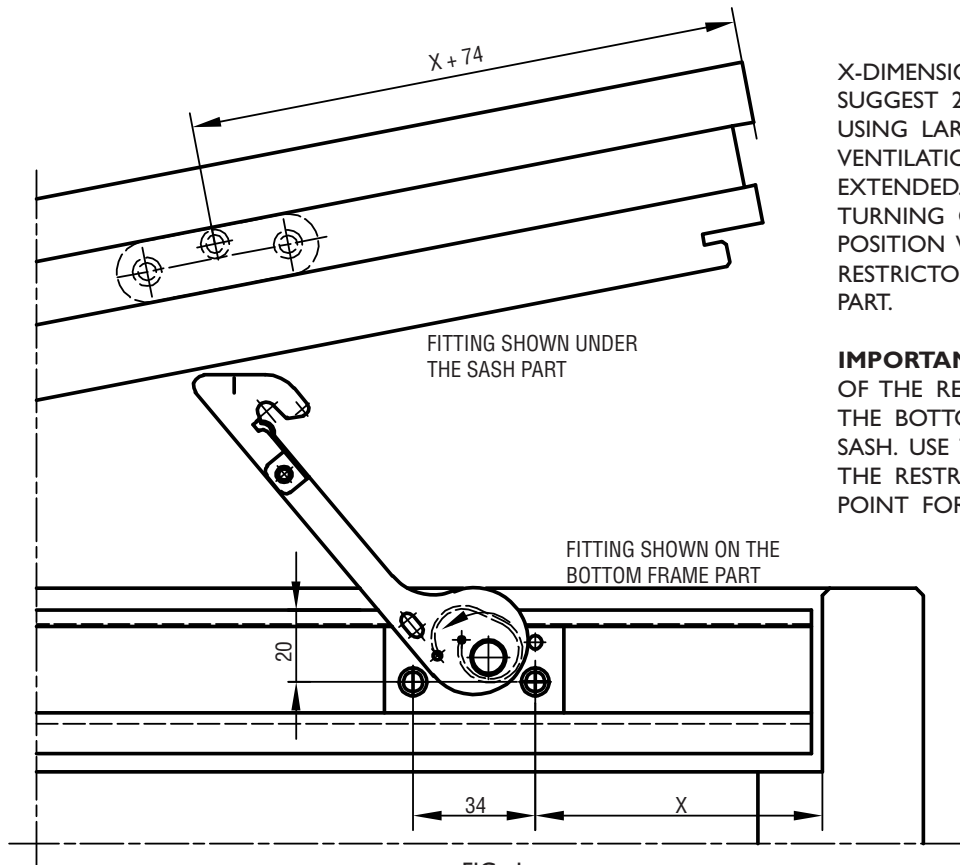

FIG. 1
RIGHT HAND ILLUSTRATION

X-DIMENSION IS OPTIONAL. WE SUGGEST 25 MM AS MINIMUM. BY USING LARGER X-DIMENSION THE VENTILATION OPENING WILL BE EXTENDED. AT THE SAME TIME THE TURNING OF SASH TO CLEANING POSITION WILL BE REDUCED AS THE RESTRICTOR WILL STOP THE SLIDING PART.

IMPORTANT: THE PIVOT CATCH OF THE RESTRICTOR IS FITTED IN THE BOTTOM CHANNEL OF THE SASH. USE THE MARK SHOWN ON THE RESTRICTOR ARM AS LOCATION POINT FOR THE PIVOT CATCH.

WHEN USING THE RESTRICTOR FOR SIDE HUNG LIFT-OFF WINDOWS MOUNT THE RESTRICTOR ON THE SUPPORT RAIL IPA NO. 21229. FIT THE BEARING BLOCK (PLASTIC) INTO THE IPA GROOVE IN THE BOTTOM CHANNEL OF THE SASH OVER THE FREE PART OF THE SUPPORT PLATE - OPPOSITE THE HINGE SIDE.

OPERATING INSTRUCTIONS:

1. OPEN THE SASH UNTIL THE RESTRICTOR CATCH ENGAGES.
2. PULL THE SASH IN APPROXIMATELY 20 MM.
3. PRESS THE RESTRICTOR ARM IN THE DIRECTION OF THE ARROW AND OPEN THE SASH.
4. WHEN THE WINDOW IS CLOSED THE RESTRICTOR RE-ENGAGES AUTOMATICALLY.

USE SCREW NO. 4.0

MAINTENANCE:

THE FITTINGS ARE NOT TO BE PAINTED. TEST THE OPERATION FROM TIME TO TIME. WHEN FITTING - LUBRICATE THE PIVOT/MOVABLE METAL PARTS OF THE MECHANISM WHILE ACTIVATING REPEATEDLY. HEREAFTER LUBRICATE MINIMUM TWICE A YEAR. DO NOT LUBRICATE THE ALUMINIUM RAILS. SEE ALSO SECTION H.

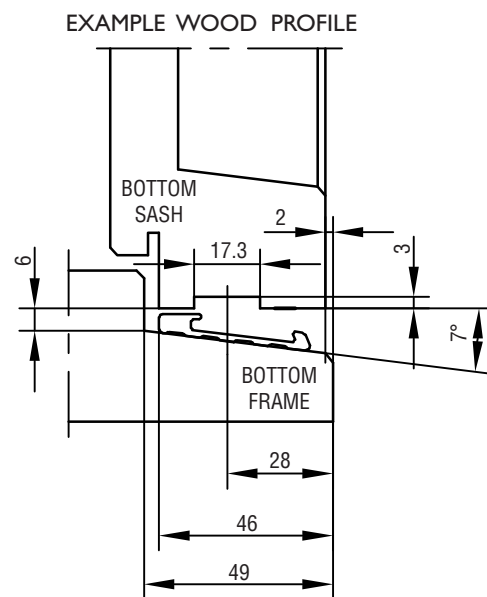
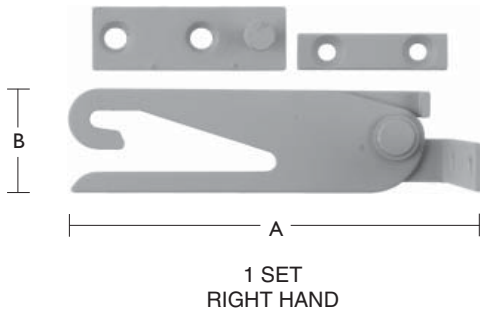
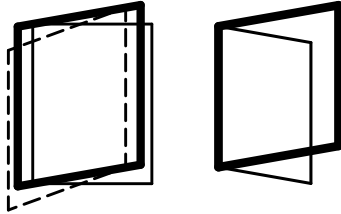

FIG. 2



SAFETY RESTRICTOR

IPA NO. 21231



ORDERING NO.									
IPA NO.	MATERIAL			SURFACE	STANDARD PACKING IN BOXES OF 5 SETS	A MM	B MM	SCREW	APPROX. WEIGHT KG / SET
	STAINLESS STEEL	LEFT	RIGHT	UNMACHINED					
21231	8	7	8	86	1	105	28	4,0	0,080

● RETAINS THE WINDOW IN OPENING POSITION 60 MM

USED IN CONJUNCTION WITH:
HINGES IPA NO.s 11173-74 & 77
SIDESWING FITTING IPA NO.s 21201-17



FITTING INSTRUCTIONS

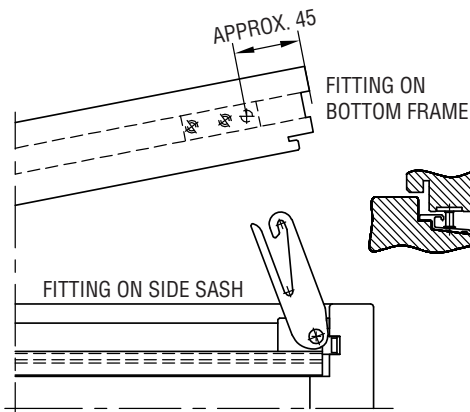

FIG. 1
RIGHT HAND ILLUSTRATION

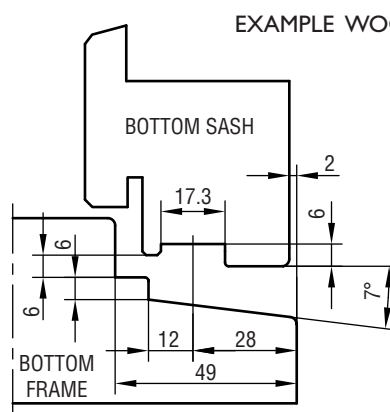

FIG. 2

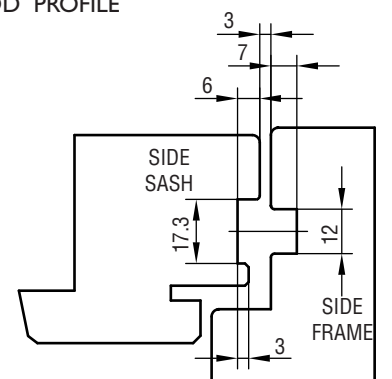

FIG. 3

OPERATING INSTRUCTIONS:

1. OPEN THE WINDOW UNTIL THE RESTRICTOR IS IN POSITION.
2. DRAW THE SASH 20 MM BACKWARDS.
3. PRESS THE RESTRICTOR AGAINST THE FRAME AND THE SASH IS RELEASED.

MAINTENANCE:

THE FITTINGS ARE NOT TO BE PAINTED. TEST THE OPERATION FROM TIME TO TIME. WHEN FITTING - LUBRICATE THE PIVOT/MOVABLE METAL PARTS OF THE MECHANISM WHILE ACTIVATING REPEATEDLY. HEREAFTER LUBRICATE MINIMUM TWICE A YEAR. SEE ALSO SECTION H.



SAFETY RESTRICTOR

IPA NO. 21233

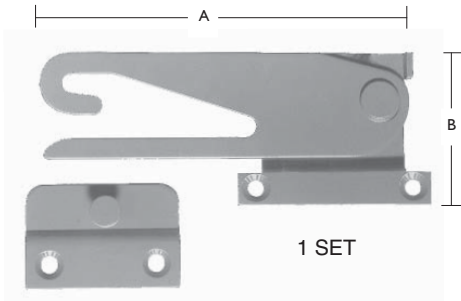
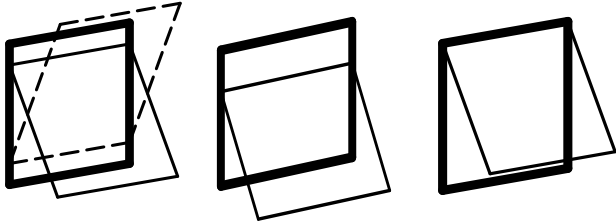

ORDERING NO.								
IPA NO.	MATERIAL	WITHOUT SPECIFICATION	SURFACE	STANDARD PACKING IN BOXES OF 5 SETS	A MM	B MM	SCREW	APPROX. WEIGHT KG / SET
	STAINLESS STEEL		UNMACHINED					
21233	8	0	86	1	97	40	3,5	0,075

- RETAINS THE WINDOW IN OPENING POSITION 60 MM

USED IN CONJUNCTION WITH:
 TOP HINGES IPA NO.s 21125-28
 REV. PROJ. GEAR IPA NO.s 21144-52 & IPA NO.s 21874-82
 CANOPY STAY IPA NO.s 21167-82



FITTING INSTRUCTIONS

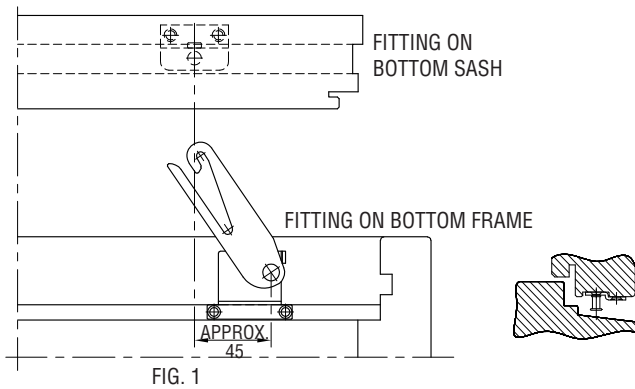

FIG. 1

OPERATING INSTRUCTIONS:

1. OPEN THE WINDOW UNTIL THE RESTRICTOR IS IN POSITION.
2. DRAW THE SASH 20 MM BACKWARDS.
3. PRESS THE RESTRICTOR TO THE RIGHT AND OPEN THE

EXAMPLE WOOD PROFILE

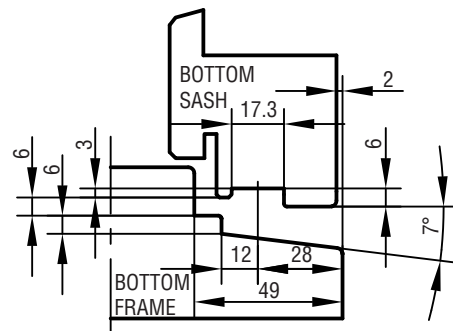
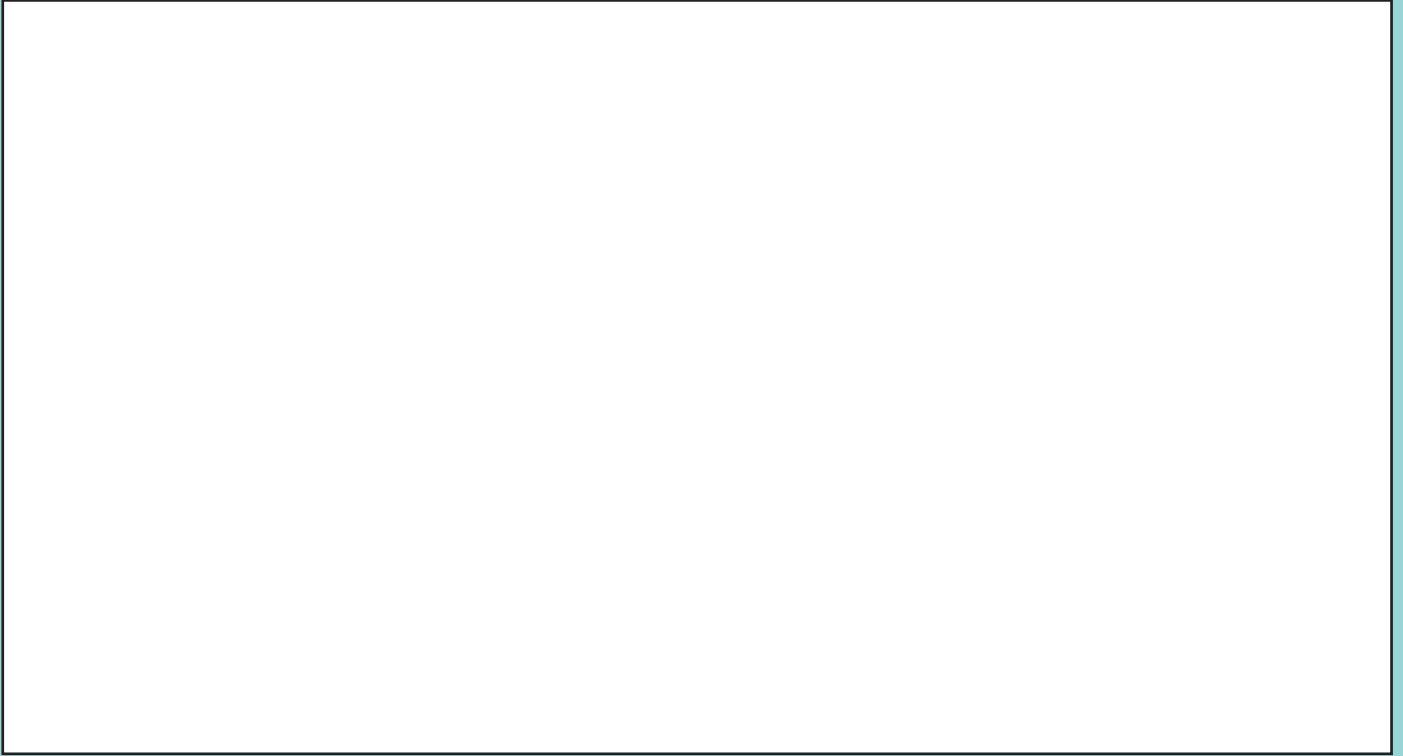

FIG. 2

MAINTENANCE:

THE FITTINGS ARE NOT TO BE PAINTED. TEST THE OPERATION FROM TIME TO TIME. WHEN FITTING - LUBRICATE THE PIVOT/MOVABLE METAL PARTS OF THE MECHANISM WHILE ACTIVATING REPEATEDLY. HEREAFTER LUBRICATE MINIMUM TWICE A YEAR. SEE ALSO SECTION H.



FITTING INSTRUCTIONS

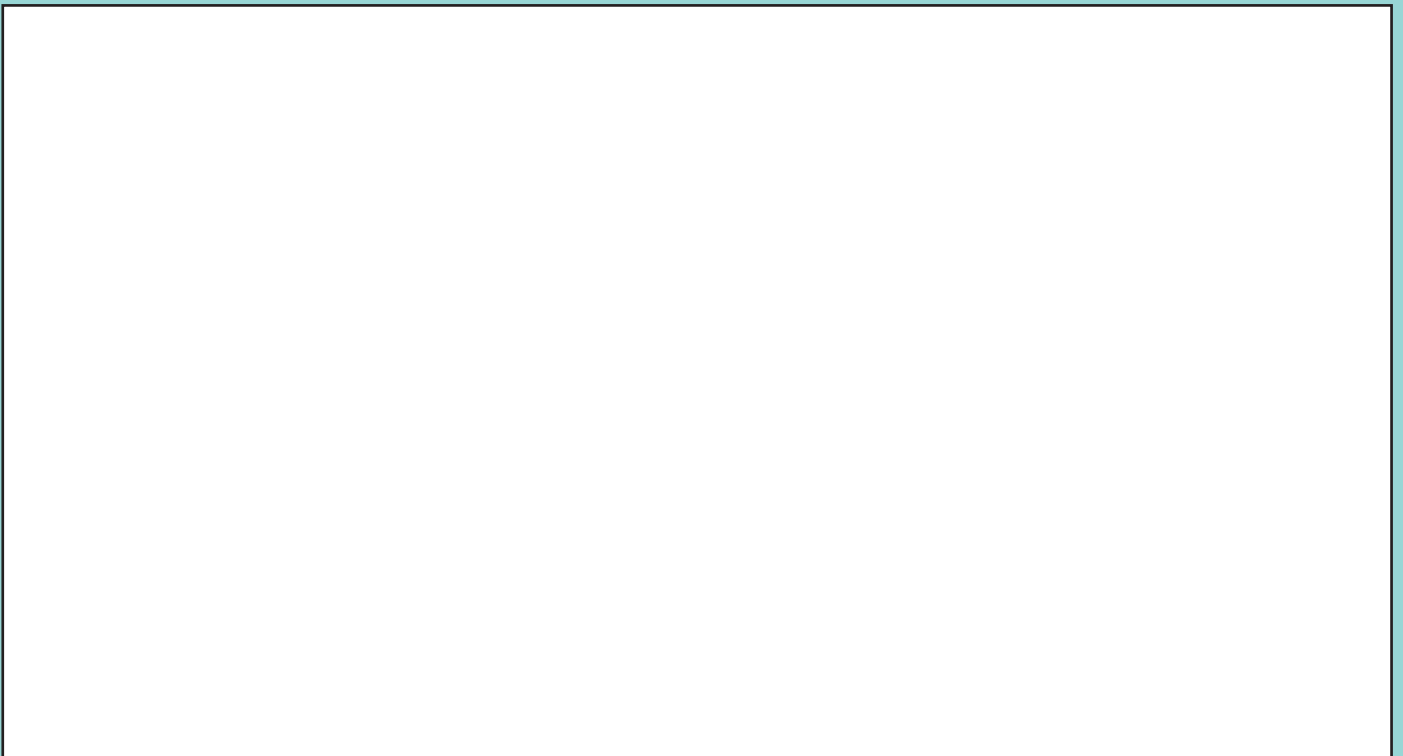



FIRE ESCAPE FITTING FOR TOP HUNG WINDOWS IPA NO. 21321

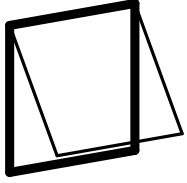

1/2 SET
RIGHT HAND

ORDERING NO.								
IPA NO.	MATERIAL	WITHOUT SPECIFICATION	SURFACE	STANDARD PACKING IN BOXES OF 5 SETS	LENGHT MM	MATERIAL MM	SCREW	APPROX. WEIGHT KG / SET
	STEEL		ELECTROPLATED					
21321	1	0	21	1	350	17x2	4,0	0,34

USED IN CONJUNCTION WITH:
TOP HINGES IPA NO.s 21125-28



FITTING INSTRUCTIONS

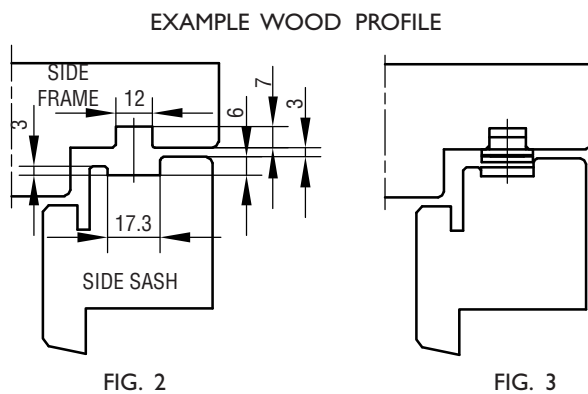
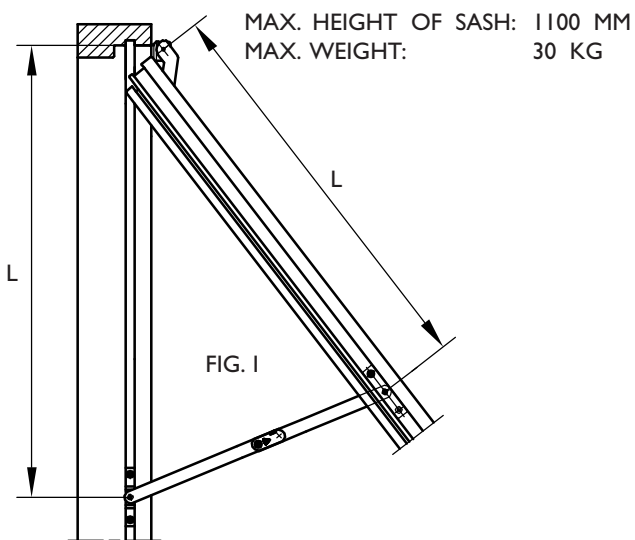

THE FITTINGS ARE PLACED IN THE GROOVES ON BOTH SIDES, SO THAT THE WANTED OPENING IS OBTAINED. MEASURES L SHOULD BE THE SAME ON BOTH SASH AND FRAME. USE SCREW NO. 4,0.

MAINTENANCE:

THE FITTINGS ARE NOT TO BE PAINTED. TEST THE OPERATION FROM TIME TO TIME. WHEN FITTING - LUBRICATE THE PIVOT/MOVABLE METAL PARTS OF THE MECHANISM WHILE ACTIVATING REPEATEDLY. HEREAFTER LUBRICATE MINIMUM TWICE A YEAR. DO NOT LUBRICATE THE ALUMINIUM RAILS. SEE ALSO SECTION H.



SAFETY RESTRICTOR

IPA NO. 21236

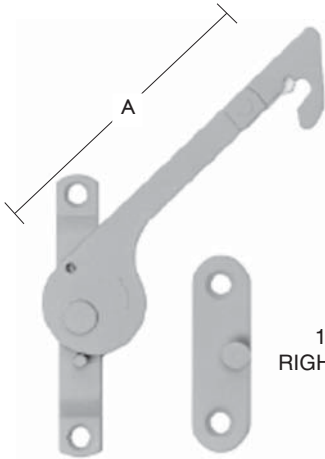
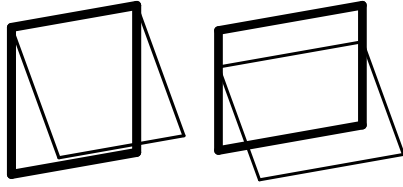

1 SET
RIGHT HAND

ORDERING NO.								
IPA NO.	MATERIAL		SURFACE		STANDARD PACKING IN BOXES OF 5 SETS	A MM	SCREW	APPROX. WEIGHT KG / SET
	STEEL	LEFT	RIGHT	ELECTROPLATED				
21236	1	7	8	21	1	92	3,5 & 4,0	0,06

USED IN CONJUNCTION WITH:
TOP HINGES IPA NO.s 21125-28
CANOPY STAY IPA NO.s 21167-82



FITTING INSTRUCTIONS

RESTRICTOR NO. 21236 CAN BE USED ON TOP HUNG AS WELL AS ON CANOPY STAY WINDOWS. PLACE THE RESTRICTOR IN THE PROFILE GROOVE IN THE BOTTOM OF THE SIDE FRAME AND PLACE THE RECEIVER IN THE PROFILE GROOVE IN THE SIDE OF THE SASH AS SHOWN ON FIG. 1. THE RESTRICTOR CAN ALSO BE USED ON A SIDE HUNG WINDOW. IN THIS CASE: PLACE THE RESTRICTOR IN THE PROFILE GROOVE IN THE TOP OF THE FRAME AND THE RECEIVER IN THE PROFILE GROOVE IN THE TOP OF THE SASH.

X-DIMENSION IS OPTIONAL. WE SUGGEST 6 MM AS A MINIMUM. BY USING LARGER X-DIMENSIONS THE VENTILATION OPENING WILL BE EXTENDED.

IMPORTANT: THE RECEIVER MUST BE FITTED IN THE PROFILE GROOVE OF THE SASH. USE THE MARK SHOWN ON THE RESTRICTOR ARM AS A LOCATION POINT FOR THE PIVOT CATCH.

OPERATING INSTRUCTIONS:

1. OPEN THE WINDOW UNTIL THE RESTRICTOR IS IN POSITION.
2. DRAW THE SASH 20 MM BACKWARDS.
3. PRESS THE RESTRICTOR IN THE DIRECTION OF THE ARROW AND OPEN THE WINDOW.
4. WHEN THE WINDOW IS CLOSED THE RESTRICTOR RE-ENGAGES AUTOMATICALLY.

FIG. 1
RIGHT HAND
ILLUSTRATION

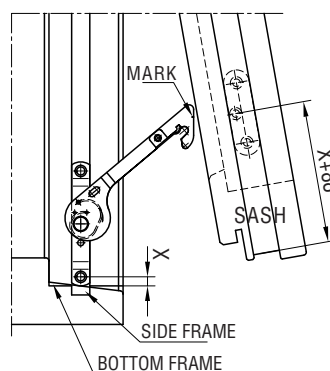

EXAMPLE WOOD PROFILE

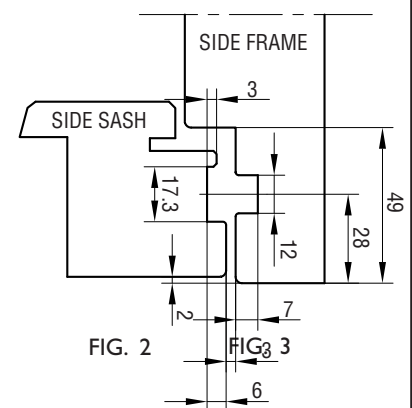

MAINTENANCE:

THE FITTINGS ARE NOT TO BE PAINTED. TEST THE OPERATION FROM TIME TO TIME. WHEN FITTING - LUBRICATE THE PIVOT/MOVABLE METAL PARTS OF THE MECHANISM WHILE ACTIVATING REPEATEDLY. HEREAFTER LUBRICATE MINIMUM TWICE A YEAR. DO NOT LUBRICATE THE ALUMINIUM RAILS. SEE ALSO SECTION H.



SUPPORT FITTING FOR WINDOWS & DOORS - ADJUSTABLE IPA NO. 21226

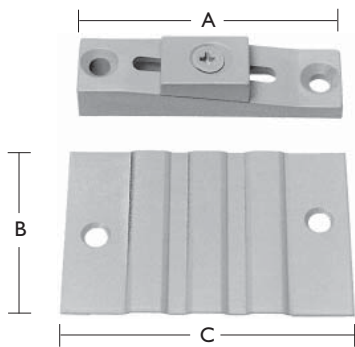
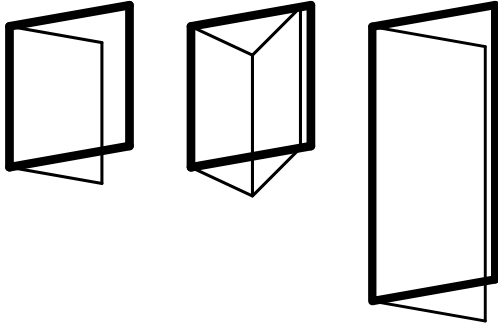

IPA NO.	ORDERING NO.				A MM	B MM	C MM	SCREW	APPROX. WEIGHT KG/100 PC.
	MATERIAL	SURFACE		STANDARD PACKING IN BOXES OF 25 PIECES					
	ALUMINIUM/PLASTIC	WITHOUT SPECIFICATION	ANODIZED						
21226	0	0	00	1	60	40	61	3,0 & 4,0	1,40



FITTING INSTRUCTIONS

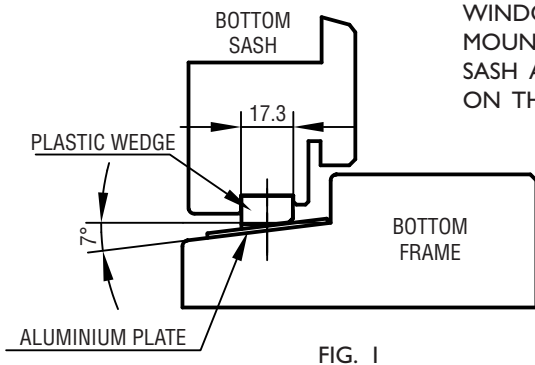

THE SUPPORT FITTING IS USED TO SUPPORT WINDOWS AND DOORS. THE PLASTIC WEDGE IS MOUNTED IN THE IPA SYSTEM GROOVE ON THE SASH AND THE ALUMINIUM RAIL IS MOUNTED ON THE BOTTOM FRAME, AS SHOWN.

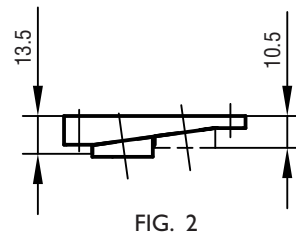

THE SUPPORT FITTING CAN BE ADJUSTED BY LOOSENING THE SCREW IN THE SMALL PLASTIC BLOCK AND BY ADJUSTING THE MENTIONED PLASTIC BLOCK TO THE LEFT OR TO THE RIGHT. MAXIMUM AND MINIMUM HEIGHT OF THE FITTING IS SHOWN ABOVE - PLEASE REMEMBER TO ADD THE THICKNESS OF THE ALUMINIUM RAIL.



FIRE-ESCAPE CATCH

IPA NO. 21156

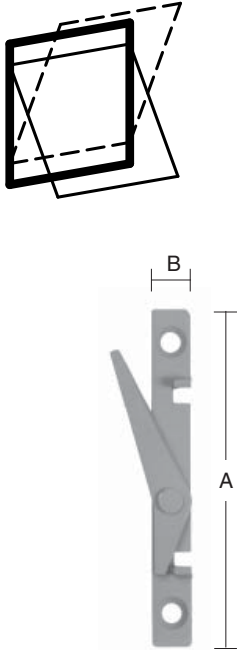

ORDERING NO.								
IPA NO.	MATERIAL	SURFACE			A MM	B MM	SCREW	APPROX. WEIGHT KG/EACH
	STEEL	WITHOUT SPECIFICATION	ELECTROPLATED	STANDARD PACKING IN BOXES OF 10 PIECES				
21156	1	0	21	1	70	8	3,0	0,02

USED IN CONJUNCTION WITH:
REVERSIBLE PROJECTING GEAR IPA NO.s 21144-52.



FITTING INSTRUCTIONS

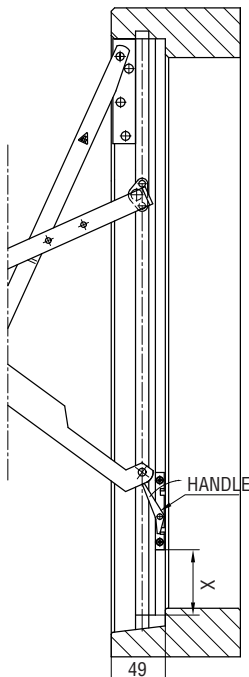

FIG. 1

IPA NO.	X
21144	50
21145	76
21146	102
21147	128
21148	155
21149	177
21150	195
21151	209
21152	223

FIG. 2

MOUNTING:

1. THE FITTING IS PLACED IN RIGHT SIDE FRAME, SEEN FROM THE INSIDE. PLACE THE FITTING AGAINST THE REAR EDGE OF THE ALUMINIUM RAIL, SEE FIG. 1.
2. TO OBTAIN MAXIMUM FIRE-ESCAPE OPENING PLACE THE FITTING ACCORDING TO DIMENSION, SEE FIG. 2.

OPERATING INSTRUCTIONS:

1. OPEN THE WINDOW UNTIL THE FIRE-ESCAPE CATCH ENGAGES.
2. THE WINDOW CAN BE CLOSED BY OPENING IT ANOTHER 2 CM, AND PULLING THE HANDLE BACKWARDS, THEN CLOSE THE WINDOW AND LET GO OF THE HANDLE WHEN THE BOTTOM ARM OF THE FITTING HAS PASSED THE FIRE-ESCAPE CATCH, SEE FIG. 1.
3. THE FIRE-ESCAPE CATCH WILL AUTOMATICALLY ENGAGE NEXT TIME THE WINDOW IS OPENED.
5. IF THE WINDOW IS FULLY REVERSED THEN THE FIRE-ESCAPE CATCH HAS TO BE RELEASED AS MENTIONED IN 2.

USE SCREW NO. 3,0

MAINTENANCE:

THE FITTINGS ARE NOT TO BE PAINTED. TEST THE OPERATION FROM TIME TO TIME. WHEN FITTING - LUBRICATE THE PIVOT/MOVABLE METAL PARTS OF THE MECHANISM WHILE ACTIVATING REPEATEDLY. HEREAFTER LUBRICATE MINIMUM TWICE A YEAR. DO NOT LUBRICATE THE ALUMINIUM RAILS. SEE ALSO SECTION H.



VENTILATION CATCH

IPA NO. 21157

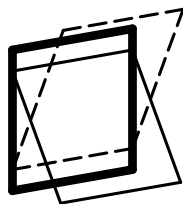

ORDERING NO.							
IPA NO.	MATERIAL	SURFACE		STANDARD PACKING IN BOXES OF 10 PIECES	A MM	SCREW	APPROX. WEIGHT KG/EACH
	STEEL	LEFT	ELECTROPLATED				
21157	1	7	21	1	20	3,0	0,02

USED IN CONJUNCTION WITH:
REVERSIBLE PROJECTING GEAR IPA NO. 21144-52, A
MINIMUM OF 20 MM BETWEEN BOTTOM ALU-RAIL AND
BOTTOM FRAME IS NEEDED.



FITTING INSTRUCTIONS

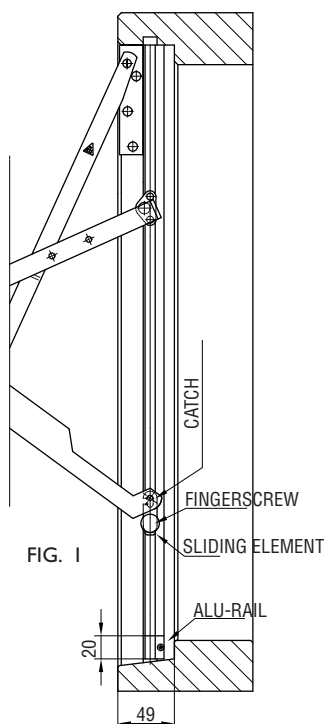

MOUNTING INSTRUCTIONS: (USE SCREW NO. 3.0)

1. THE FITTING IS MOUNTED ON THE RIGHT SIDE SEEN FROM THE INSIDE. THE FITTING IS MOUNTED AT THE BOTTOM END OF THE ALURAIL OF 21144-52, SEE FIG. 1.

IMPORTANT: THE SMALL PIECE OF ALU-RAIL FOR THE VENTILATION CATCH MUST BE PLACED CAREFULLY RIGHT UNDER THE ALU-RAIL IN THE FRAME. MAKE SURE THAT NOTHING PREVENTS THE SMOOTH MOVING OF THE VENTILATION CATCH BETWEEN THE TWO ALU-RAILS.

2. THE FINGERSCREW IS LOOSENED AND THE FITTING IS CONNECTED TO THE BOTTOM SLIDING ELEMENT OF 21144-52, THIS WAY THE FITTING WILL ALWAYS FOLLOW THE BOTTOM SLIDING ELEMENT OF 21144-52.

OPERATING INSTRUCTIONS:

1. THE WINDOW IS OPENED TO THE WANTED POSITION AND THE FINGERSCREW IS FASTENED.
2. WHEN CHANGING THE OPENING POSITION OF THE WINDOW THE FINGER-SCREW MUST BE LOOSENED BEFORE OPERATING THE WINDOW.

IMPORTANT: THE VENTILATION FITTING WILL BE DESTROYED IF THE FINGER-SCREW IS NOT LOOSENED BEFORE OPERATING THE WINDOW.

MAINTENANCE:

THE FITTINGS ARE NOT TO BE PAINTED. TEST THE OPERATION FROM TIME TO TIME. WHEN LUBRICATING THE THREAD AVOID LUBRICANT BETWEEN THE SLIDING ELEMENT AND THE ALU-RAIL AS THIS COULD RESULT IN MAL-FUNKTION OF THE FITTING. SEE ALSO SECTION H.



SAFETY RESTRICTOR

IPA NO. 21158

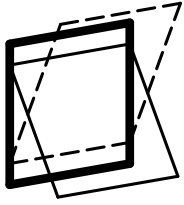

ORDERING NO.					A MM	MATERIAL MM	SCREW	APPROX WEIGHT KG/EACH
IPA NO.	MATERIAL	SURFACE		STANDARD PACKING IN BOXES OF 10 PIECES				
21158	STEEL 1	LEFT 7	ELECTROPLATED 21	1	385	4	3,0	0,12

USED IN CONJUNCTION WITH:
REVERSIBLE PROJECTING GEAR IPA NO.s 21144-52
AND IPA NO.s 21874-82.



FITTING INSTRUCTIONS

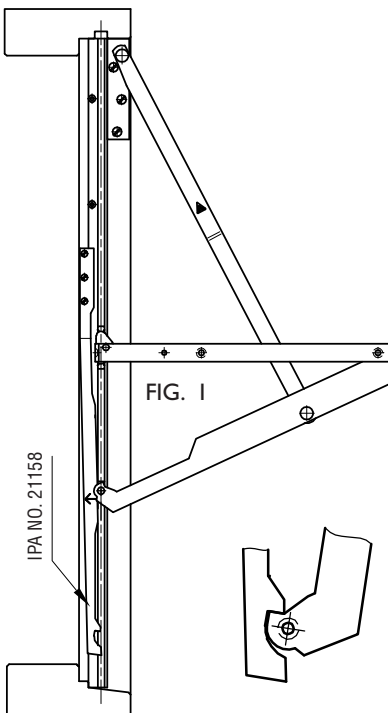

MOUNTING INSTRUCTIONS:

1. SAFETY CATCH IPA NO. 21158 IS MOUNTED ON THE LEFT SIDE SEEN FROM THE INSIDE - USING SCREW NO. 3.0 SEE FIG. 1. THE SAFETY OPENING OF THE WINDOW IS APROX. 100 MM.

OPERATING INSTRUCTIONS:

1. THE WINDOW IS OPENED UNTIL THE SAFETY CATCH AUTOMATICALLY ENGAGES.
2. TO OPEN THE WINDOW - CLOSE THE WINDOW APROX. 2 CM. PRESS THE SAFETY CATCH, SEE FIG. 1, IN THE DIRECTION SHOWN BY THE ARROW, THEN OPEN THE WINDOW.
3. THE SAFETY CATCH AUTOMATICALLY RE-ENGAGES NEXT TIME THE WINDOW IS OPENED.

USE SCREW NO. 3.0.

MAINTENANCE:

THE FITTINGS ARE NOT TO BE PAINTED. TEST THE OPERATION FROM TIME TO TIME. WHEN FITTING - LUBRICATE THE PIVOT/MOVABLE METAL PARTS OF THE MECHANISM WHILE ACTIVATING REPEATEDLY. HEREAFTER LUBRICATE MINIMUM TWICE A YEAR. DO NOT LUBRICATE THE ALUMINIUM RAILS. SEE ALSO SECTION H.



SAFETY RESTRICTORS

IPA NO.s 21162-63

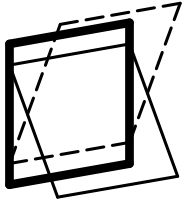

ORDERING NO.							
IPA NO.	MATERIAL	SURFACE		STANDARD PACKING IN BOXES OF 20 PIECES	A MM	SCREW	APPROX. WEIGHT KG/EACH
	STEEL	LEFT	ELECTROPLATED				
21162	1	7	21	1	170	3,5	0,06
21163	1	7	21	1	170	3,5	0,06

USED IN CONJUNCTION WITH:
 REVERSIBLE PROJECTING GEAR IPA NO.s 21144-52
 AND IPA NO.s 21874-82.



FITTING INSTRUCTIONS

MOUNTING INSTRUCTIONS:

1. THE SAFETY CATCH IS PLACED ON THE LEFT SIDE FRAME - SEEN FROM THE INSIDE - WITH THE FRONT EDGE OF THE MOUNTING PLATE PLACED AGAINST THE EDGE OF THE ALURAIL.
2. HORIZONTALLY THE FITTING CAN BE PLACED FREELY DEPENDING ON THE WANTED OPENING.

OPERATING INSTRUCTIONS:

1. THE WINDOW IS OPENED UNTIL THE SAFETY CATCH AUTOMATICALLY ENGAGES.
2. TO FURTHER OPEN THE WINDOW CLOSE THE WINDOW APROX. 2 CM, PRESS THE BOTTOM PART OF THE SAFETY CATCH IN THE DIRECTION SHOWN BY THE ARROW. PUSH OPEN THE WINDOW. LET GO OF THE SAFETY CATCH AND IT WILL ENGAGE IN THE NEXT POSITION.
3. TO FULLY OPEN THE WINDOW REPEAT NO. 2.
4. NEXT TIME THE WINDOW IS OPENED THE SAFETY CATCH AUTOMATICALLY RE-ENGAGES.

MAINTENANCE:

THE FITTINGS ARE NOT TO BE PAINTED. TEST THE OPERATION FROM TIME TO TIME. WHEN FITTING - LUBRICATE THE PIVOT/MOVABLE METAL PARTS OF THE MECHANISM WHILE ACTIVATING REPEATEDLY. HEREAFTER LUBRICATE MINIMUM TWICE A YEAR. DO NOT LUBRICATE THE ALUMINIUM RAILS. SEE ALSO SECTION H.

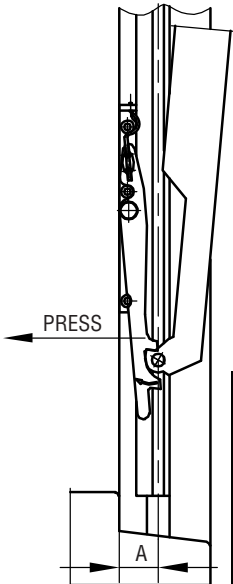

IPA NR.	A
21162	MIN. 50.5
21163	MIN. 48.5 MAX. 50.5

FIG. 1

FIG. 2

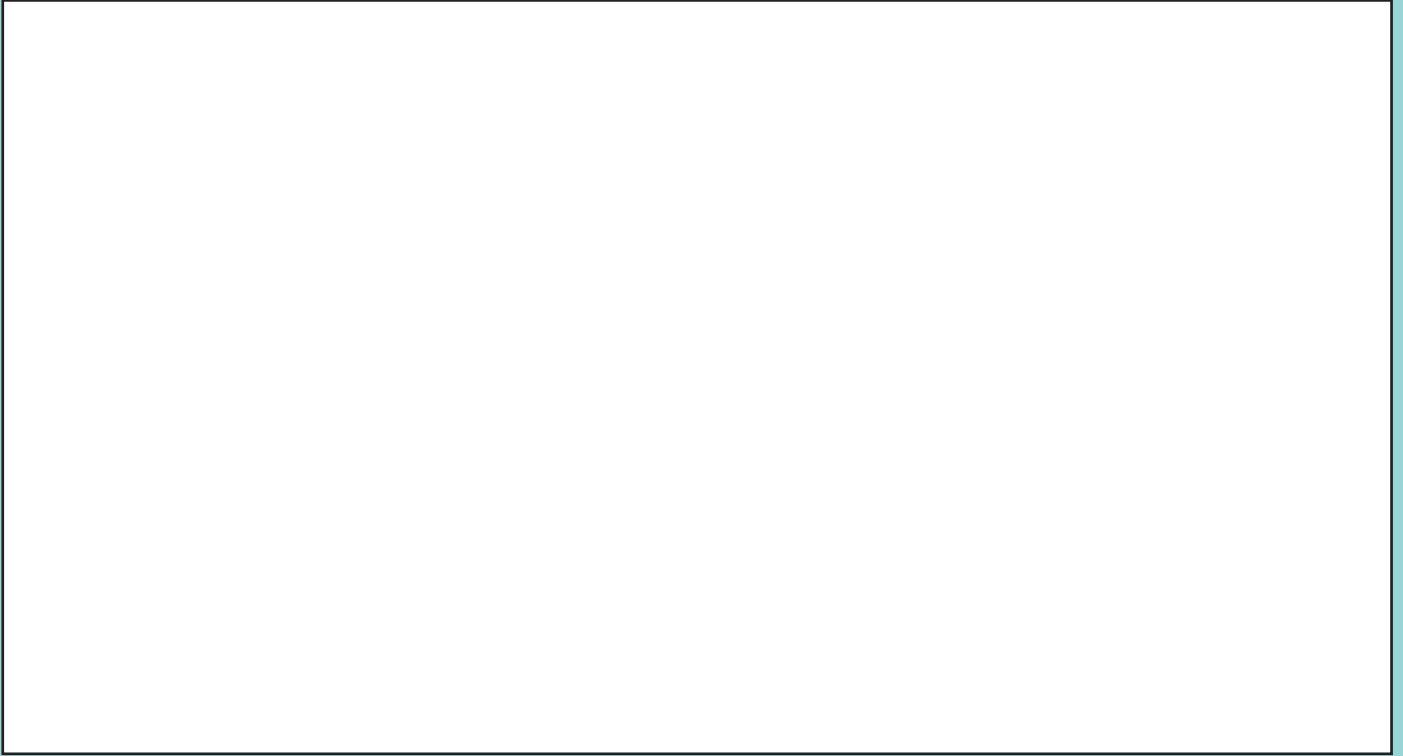

FITTING INSTRUCTIONS

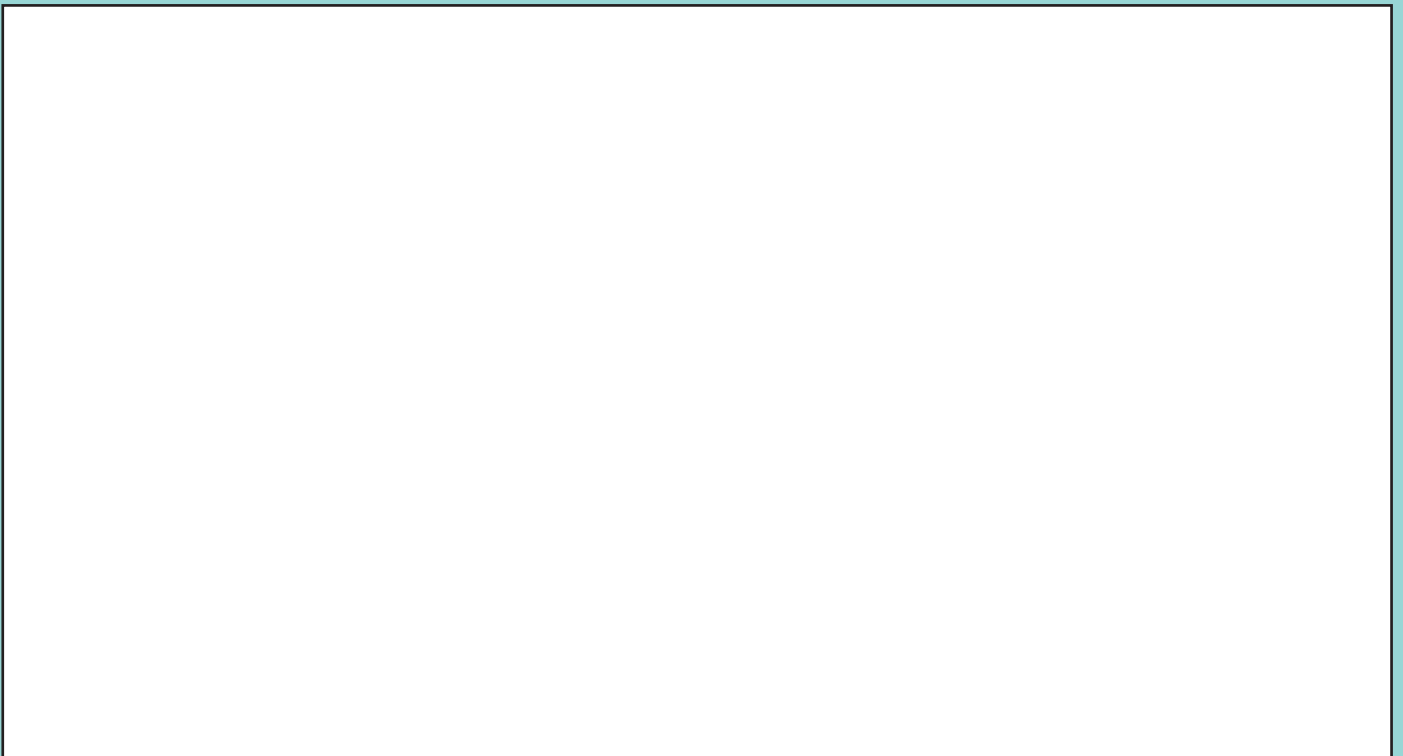



A large, empty white rectangular area with a thin black border, intended for drawing or writing.



SAFETY RESTRICTOR

IPA NO. 21232

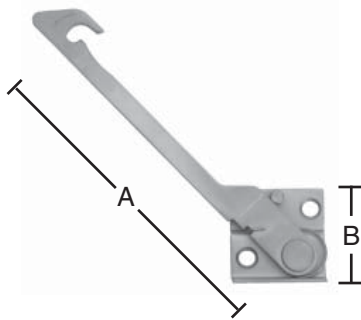
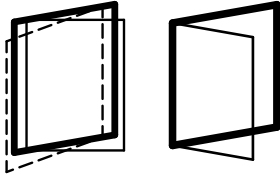

21232
LEFT HAND



21218 - LEFT HAND



21219



21220 - LEFT HAND

RESTRICTOR

ORDERING NO.											
IPA NO.	MATERIAL				SURFACE		STANDARD PACKING IN BOXES OF 10 PCS.	A MM	B MM	SCREW	APPROX. WEIGHT KG / EACH
	STAINLESS STEEL		LEFT	RIGHT	UNMACHINED						
21232	8		7	8	86		1	119	34,5	4,0	0,05

- MOUNTED ON THE SASH
- EASY TO OPERATE
- STAINLESS STEEL
- RETAINS THE WINDOW IN VENTILATION POSITION

RESTRICTOR CATCH

ORDERING NO.									
IPA NO.	MATERIAL		W/O SPECIFICATION		SURFACE		STANDARD PACKING IN BOXES OF 10 PCS.	APPROX. WEIGHT KG / EACH	
	STEEL	STAINLESS STEEL	LEFT	RIGHT	ELECTROPLATED	UNMACHINED			
21218	-	8	-	7	8	-	86	1	0,03
21219	-	8	0	-	-	-	86	1	0,03
21220	1	-	-	7	8	21	-	1	0,01

- IPA NO. 21218 IS TO BE USED ON WINDOWS WITH EXTRA REBATE SILL
- IPA NO. 21219 IS TO BE USED ON WINDOWS WITH 7° EVEN SILL
- IPA NO. 21220 IS TO BE USED IN CONJUNCTION WITH IPA NO. 21281-86

IPA NO. 21218 & 21219 ARE SUPPLIED WITH SUPPORT FITTING TO ENSURE A SAFE CATCH BY EACH OPENING.



FITTING INSTRUCTIONS

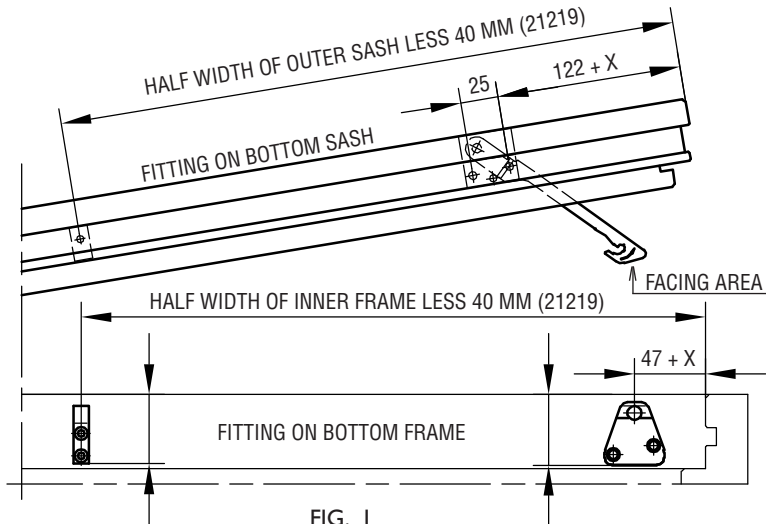

FIG. 1
RIGHT HAND

X-DIMENSION IS OPTIONAL. WE SUGGEST 6 MM AS MINIMUM. BY USING LARGER X-DIMENSION THE VENTILATION OPENING WILL BE EXTENDED. AT THE SAME TIME THE TURNING OF SASH TO CLEANING POSITION WILL BE REDUCED AS THE RESTRICTOR WILL STOP THE SLIDING PART.

EXAMPLES WOOD PROFILES

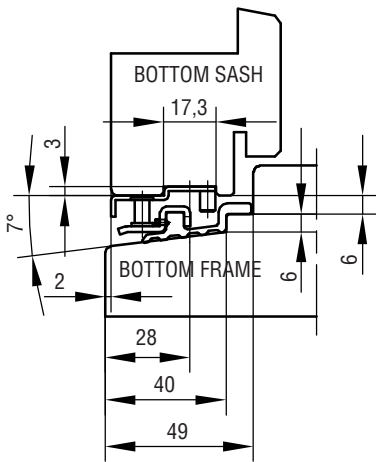

FIG. 2
IPA NO. 21220

IS USED IN CONJUNCTION WITH IPA NO. 21281-86. THE PIVOT CATCH IS MOUNTED ON THE BOTTOM ALU-RAIL.

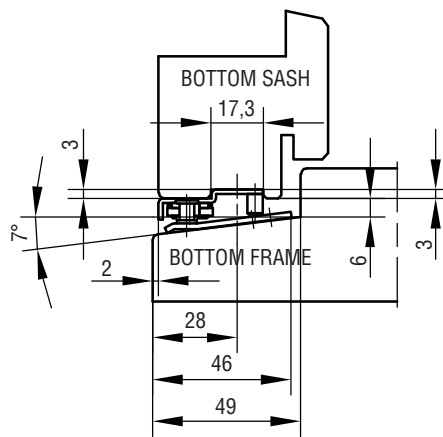

FIG. 3
IPA NO. 21219

IS USED ON WINDOWS WITH 7° EVEN SILL. THE PIVOT CATCH AND THE SUPPORT FITTING IS MOUNTED 46 MM FROM THE FRONT OF BOTTOM FRAME

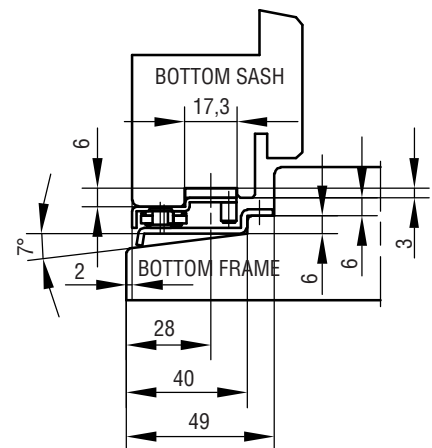

FIG. 4
IPA NO. 21218

IS USED ON WINDOWS WITH EXTRA REBATE SILL. A FITTING PLATE HAS TO BE MOUNTED UNDER THE RESTRICTOR ON THE BOTTOM SASH

OPERATING INSTRUCTIONS:

1. OPEN THE WINDOW UNTIL THE RESTRICTOR ENGAGES.
2. PULL THE SASH APPROXIMATELY 20 MM BACKWARDS.
3. PRESS THE RESTRICTOR OUTWARDS AS YOU OPEN THE WINDOW.
4. WHEN THE WINDOW IS CLOSED THE RESTRICTOR RE-ENGAGES AUTOMATICALLY.

MAINTENANCE:

THE FITTINGS ARE NOT TO BE PAINTED. TEST THE OPERATION FROM TIME TO TIME. WHEN FITTING - LUBRICATE THE PIVOT/MOVABLE METAL PARTS OF THE MECHANISM WHILE ACTIVATING REPEATEDLY. HEREAFTER LUBRICATE MINIMUM TWICE A YEAR. DO NOT LUBRICATE THE ALUMINIUM RAILS. SEE ALSO SECTION H.

USE SCREW NO. 4.0 FOR IPA NO. 21232+21219-20
USE SCREW NO. 3.5 FOR IPA NO. 21218



ESPAGNOLETTES

WITH MUSHROOM HEAD BOLTS

IPA NO.s 23051-60 & 23061-70

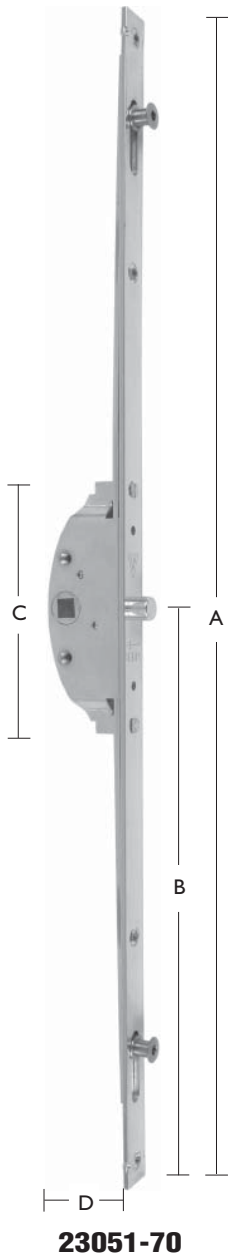
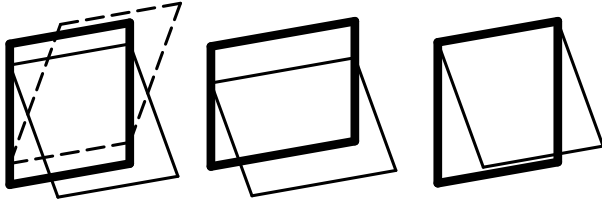

ORDERING NO.						A MM	B MM	BACKSET MM	PIN MM	C MM	D MM	FACEPLATE MM	THICKNESS PLATE MM	SCREW	APPROX. WEIGHT KG / EACH
IPA NO.	MATERIAL	SURFACE		STANDARD PACKING IN BOXES OF 10 PIECES.	INDUSTRY / PACKING IN BOXES OF 25 PIECES.										
	STEEL	SQUARE EDGES	ELECTROPLATED												
23051	1	6	21	1	-	300	150	25	8	106	34	16/17	2,5	4,0	0,24
23052	1	6	21	1	2	400	200	25	8	106	34	16/17	2,5	4,0	0,29
23053	1	6	21	1	-	500	250	25	8	106	34	16/17	2,5	4,0	0,34
23054	1	6	21	1	2	600	300	25	8	106	34	16/17	2,5	4,0	0,39
23055	1	6	21	1	-	700	350	25	8	106	34	16/17	2,5	4,0	0,44
23056	1	6	21	1	2	800	400	25	8	106	34	16/17	2,5	4,0	0,49
23057	1	6	21	1	-	900	450	25	8	106	34	16/17	2,5	4,0	0,54
23058	1	6	21	1	2	1000	500	25	8	106	34	16/17	2,5	4,0	0,59
23059	1	6	21	1	-	1100	550	25	8	106	34	16/17	2,5	4,0	0,64
23060	1	6	21	1	2	1200	600	25	8	106	34	16/17	2,5	4,0	0,69
23061	1	6	21	1	-	300	150	28	8	106	37	16/17	2,5	4,0	0,24
23062	1	6	21	1	-	400	200	28	8	106	37	16/17	2,5	4,0	0,29
23063	1	6	21	1	-	500	250	28	8	106	37	16/17	2,5	4,0	0,34
23064	1	6	21	1	2	600	300	28	8	106	37	16/17	2,5	4,0	0,39
23065	1	6	21	1	-	700	350	28	8	106	37	16/17	2,5	4,0	0,44
23066	1	6	21	1	2	800	400	28	8	106	37	16/17	2,5	4,0	0,49
23067	1	6	21	1	-	900	450	28	8	106	37	16/17	2,5	4,0	0,54
23068	1	6	21	1	2	1000	500	28	8	106	37	16/17	2,5	4,0	0,59
23069	1	6	21	1	-	1100	550	28	8	106	37	16/17	2,5	4,0	0,64
23070	1	6	21	1	2	1200	600	28	8	106	37	16/17	2,5	4,0	0,69

ACCESSORIES - SEE SECTION F

- CONSEALED FITTINGS
- IMPROVED SECURITY IN CLOSED POSITION
- GUIDING PIN FOR SASH
- ADJUSTABLE MUSHROOM HEAD BOLTS



FITTING INSTRUCTIONS

IPA NO.	L MM	C MM	A MM	B MM
23051	300	195	25	34
23052	400	295		
23053	500	395		
23054	600	495		
23055	700	595		
23056	800	695		
23057	900	795		
23058	1000	895		
23059	1100	995		
23060	1200	1095		
23061	300	195	28	37
23062	400	295		
23063	500	395		
23064	600	495		
23065	700	595		
23066	800	695		
23067	900	795		
23068	1000	895		
23069	1100	995		
23070	1200	1095		

FIG. 1

EXAMPLE WOOD PROFILE

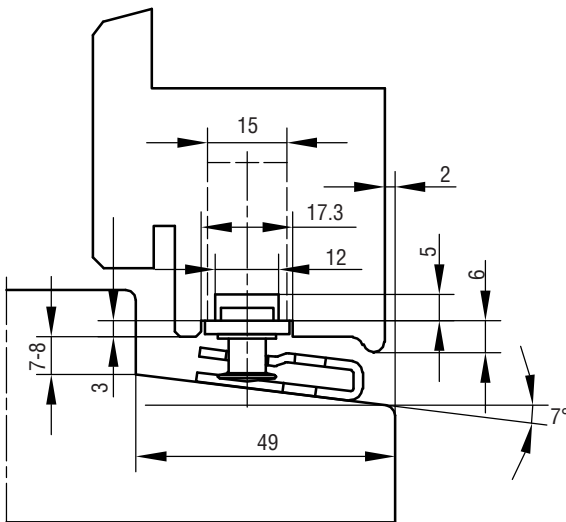
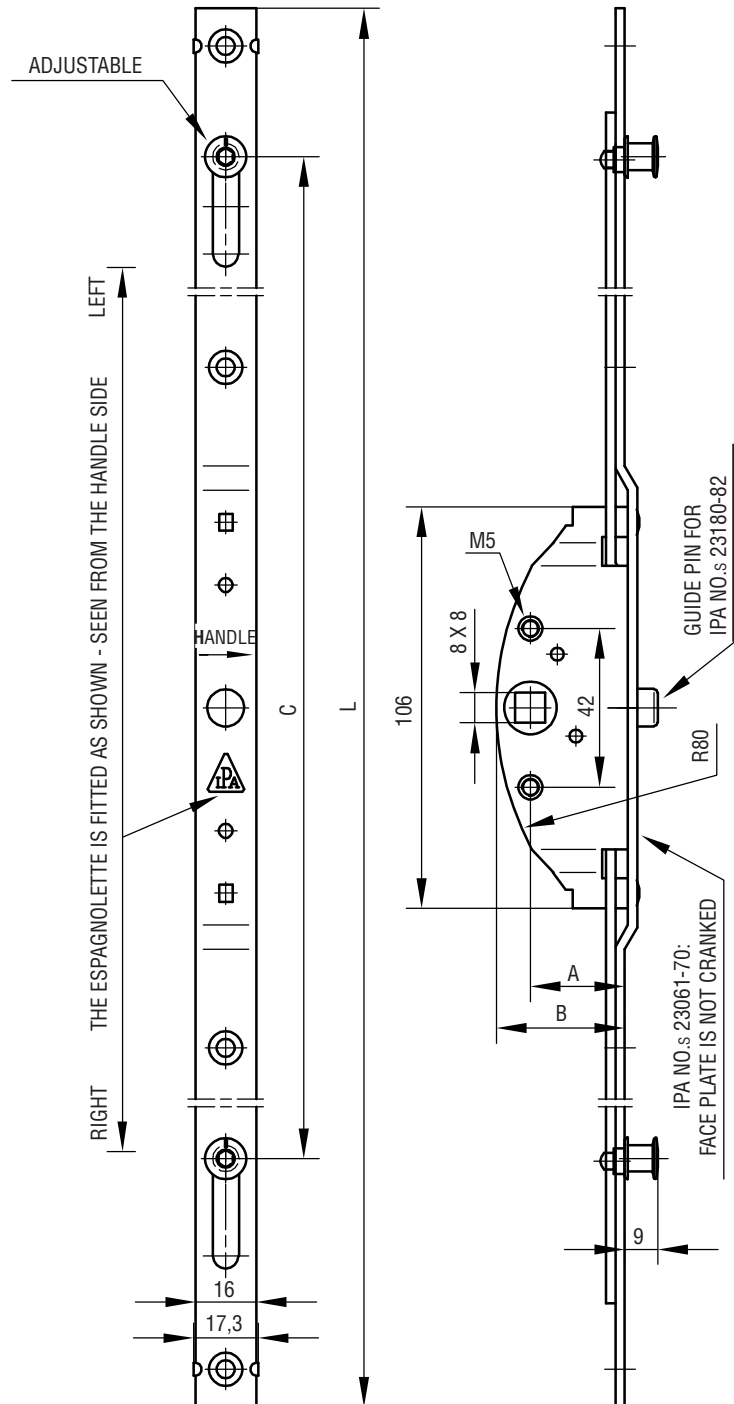

FIG. 2

SHOWN WITH RECEIVER IPA NO. 23190



MAINTENANCE:

THE FITTINGS ARE NOT TO BE PAINTED. TEST THE OPERATION FROM TIME TO TIME. WHEN MOUNTING - LUBRICATE THE PIVOT/MOVABLE METAL PARTS OF THE MECHANISM WHILE ACTIVATING REPEATEDLY. HEREAFTER LUBRICATE MINIMUM TWICE A YEAR. SEE ALSO SECTION H.



ESPAGNOLETTES

WITH SIDE BOLTS

IPA NO.s 23141-48 & 23285-86

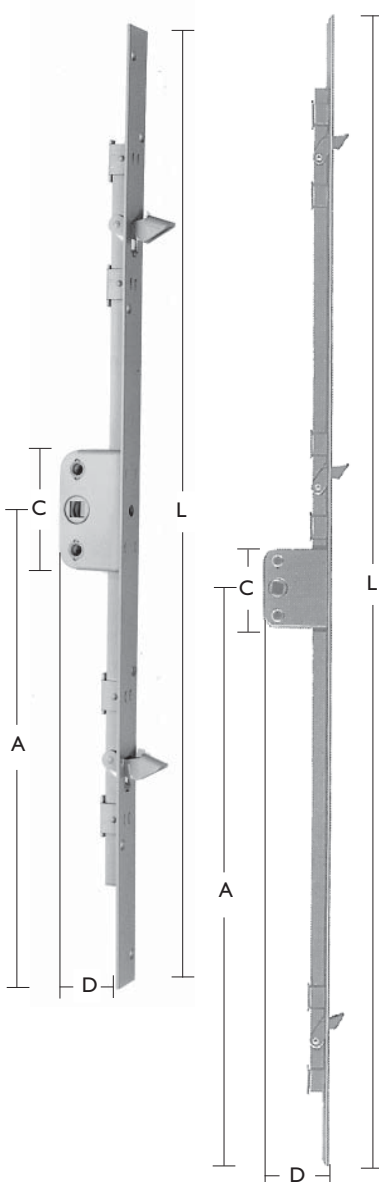
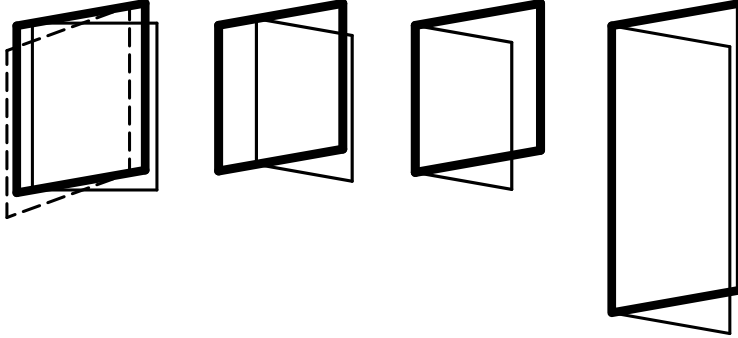

23141-48

23285-86

ORDERING NO.															
IPA NO.	MATERIAL	SURFACE		STANDARD PACKING IN BOXES OF 5 PIECES.	L MM	A MM	BACKSET MM	PIN MM	C MM	D MM	FACEPLATE MM	THICKNESS PLATE MM	THREADED NIPPLE FOR HANDLE MM	SCREW	APPROX. WEIGHT KG / EACH
	STEEL	SQUARE EDGES	ELECTROPLATED												
23141	1	6	21	1	500	250	25	8	63	35	17	2	5	3,0	0,30
23142	1	6	21	1	500	250	28	8	63	38	17	2	5	3,0	0,30
23143	1	6	21	1	800	400	25	8	63	35	17	2	5	3,0	0,50
23144	1	6	21	1	800	400	28	8	63	38	17	2	5	3,0	0,50
23145	1	6	21	1	1000	500	25	8	63	35	17	2	5	3,0	0,60
23146	1	6	21	1	1000	500	28	8	63	38	17	2	5	3,0	0,60
23147	1	6	21	1	1300	650	25	8	63	35	17	2	5	3,0	0,80
23148	1	6	21	1	1300	650	28	8	63	38	17	2	5	3,0	0,80
23285	1	6	21	1	2110	1050	40	8	63	50	17	2	5	3,0	1,20
23286	1	6	21	1	2110	1050	40	8	63	50	17	2	5	3,0	1,20

ACCESSORIES - SEE SECTION F

- CONSEALED FITTINGS
- 19 MM SIDE BOLTS



FITTING INSTRUCTIONS

IPA NO.s	L MM	A MM	B MM	C MM BACKSET	D MM	E MM	F MM	G MM
23141	500	250	140	25	35	-	-	-
23142	500	250	140	28	38	-	-	-
23143	800	400	290	25	35	-	-	-
23144	800	400	290	28	38	-	-	-
23145	1000	500	390	25	35	-	-	-
23146	1000	500	390	28	38	-	-	-
23147	1300	650	540	25	35	-	-	-
23148	1300	650	540	28	38	-	-	-
23285	2110	1050	1060	40	50	660	840	90
23286	2110	1050	1060	40	50	450	840	90

EXAMPLE WOOD PROFILE
IPA NO.s 23141-48

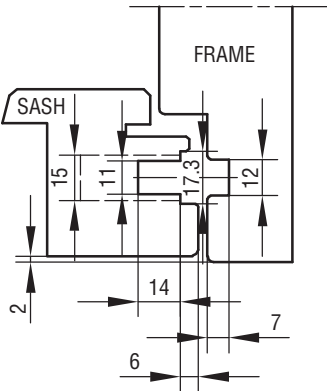

EXAMPLE WOOD PROFILE
IPA NO.s 23285-86

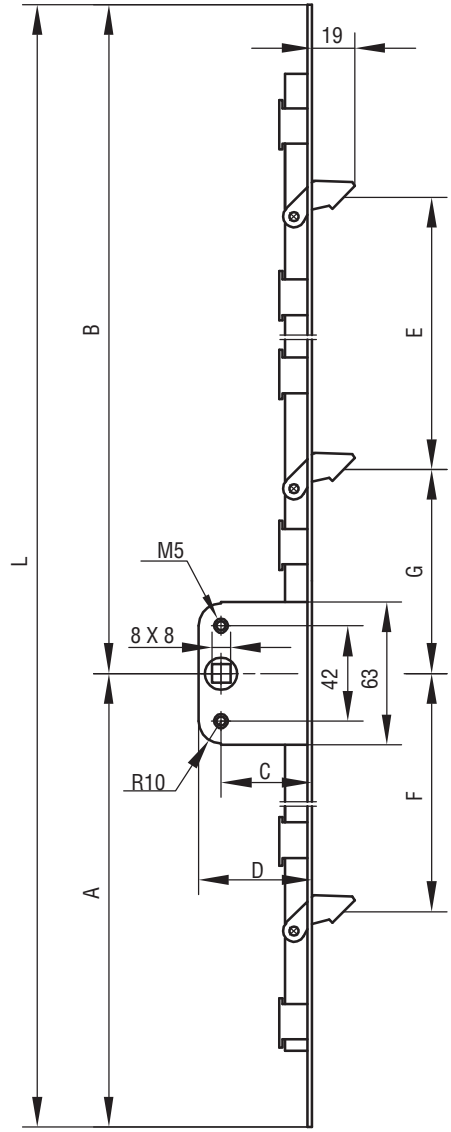
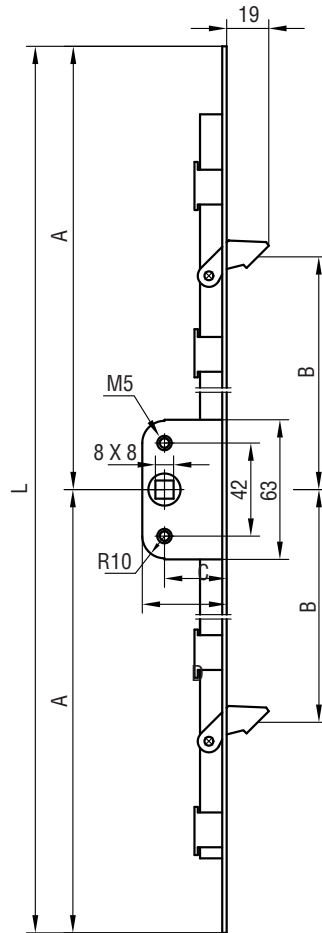
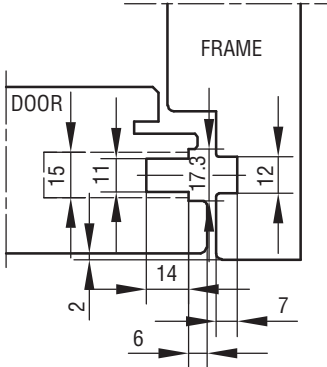

- 23141-48: FACE PLATE CAN BE SHORTENED 50 MM IN EACH END.
- 23285: AT HANDLE HEIGHT 1050 MM THE FACE PLATE CAN BE SHORTENED IN THE TOP TO 1850 MM.
- 23286: AT HANDLE HEIGHT 1050 MM THE FACE PLATE CAN BE SHORTENED IN THE TOP TO 1640 MM.

MAINTENANCE:
THE FITTINGS ARE NOT TO BE PAINTED. TEST THE OPERATION FROM TIME TO TIME.
WHEN MOUNTING - LUBRICATE THE PIVOT/ MOVABLE METAL PARTS OF THE MECHANISM WHILE ACTIVATING REPEATEDLY. HEREAFTER LUBRICATE MINIMUM TWICE A YEAR. SEE ALSO SECTION H.



ESPAGNOLETTES

WITH ROLLER BOLTS

IPA NO.s 23151-70

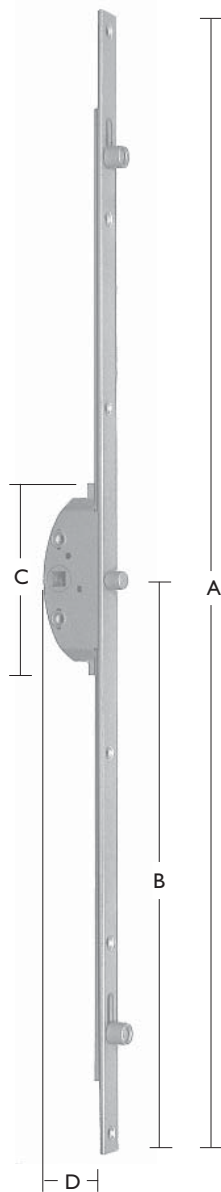
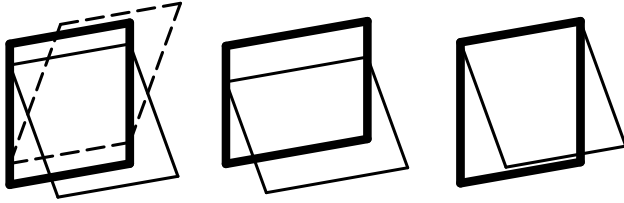

23151-70

ORDERING NO.															
IPA NO.	MATERIAL	SURFACE		STANDARD PACKING IN BOXES OF 10 PIECES	A MM	B MM	BACKSET MM	PIN MM	C MM	D MM	FACE PLATE MM	THICKNESS PLATE MM	THREADED HOLE FOR HANDLE MM	SCREW	APPROX. WEIGHT KG / EACH
	STEEL	SQUARE EDGES	ELECTROPLATED												
23151	1	6	21	1	300	150	25	8	106	34	16/17	2,5	5	4,0	0,24
23152	1	6	21	1	400	200	25	8	106	34	16/17	2,5	5	4,0	0,29
23153	1	6	21	1	500	250	25	8	106	34	16/17	2,5	5	4,0	0,34
23154	1	6	21	1	600	300	25	8	106	34	16/17	2,5	5	4,0	0,39
23156	1	6	21	1	800	400	25	8	106	34	16/17	2,5	5	4,0	0,49
23158	1	6	21	1	1000	500	25	8	106	34	16/17	2,5	5	4,0	0,59
23160	1	6	21	1	1200	600	25	8	106	34	16/17	2,5	5	4,0	0,69
23161	1	6	21	1	300	150	28	8	106	37	16/17	2,5	5	4,0	0,24
23162	1	6	21	1	400	200	28	8	106	37	16/17	2,5	5	4,0	0,29
23163	1	6	21	1	500	250	28	8	106	37	16/17	2,5	5	4,0	0,34
23164	1	6	21	1	600	300	28	8	106	37	16/17	2,5	5	4,0	0,39
23166	1	6	21	1	800	400	28	8	106	37	16/17	2,5	5	4,0	0,49
23168	1	6	21	1	1000	500	28	8	106	37	16/17	2,5	5	4,0	0,59
23170	1	6	21	1	1200	600	28	8	106	37	16/17	2,5	5	4,0	0,69

ACCESSORIES - SEE SECTION F

- CONCEALED FITTINGS
- IMPROVED SECURITY IN CLOSED POSITION
- GUIDE PIN FOR SASH



FITTING INSTRUCTIONS

IPA NO.	L MM	C MM	A MM BACKSET	B MM
23151	300	195	25	34
23152	400	295		
23153	500	395		
23154	600	495		
23156	800	695		
23158	1000	895		
23160	1200	1095		
23161	300	195	28	37
23162	400	295		
23163	500	395		
23164	600	495		
23166	800	695		
23168	1000	895		
23170	1200	1095		

FIG. 1

EXAMPLE WOOD PROFILE

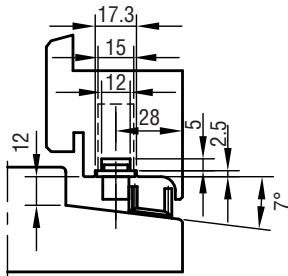

FIG. 2

SHOWN WITH RECEIVER IPA NO. 23183

WOOD PROFILE FOR IPA SYSTEM FITTINGS

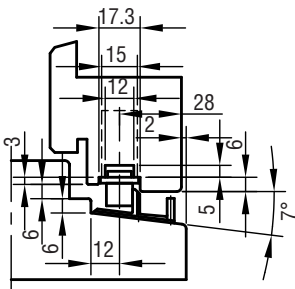

FIG. 3

SHOWN WITH RECEIVER IPA NO. 23185

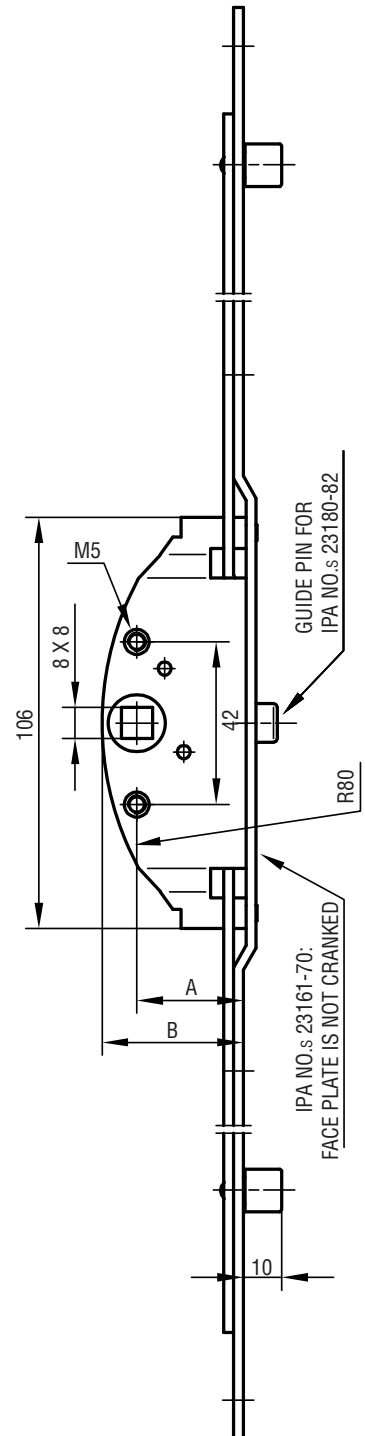
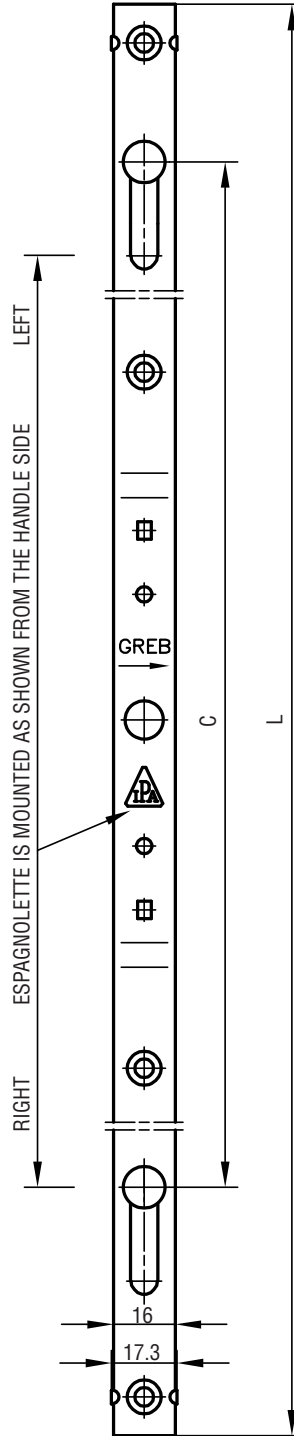

FIG. 4

MAINTENANCE:

THE FITTINGS ARE NOT TO BE PAINTED. TEST THE OPERATION FROM TIME TO TIME. WHEN MOUNTING - LUBRICATE THE PIVOT/MOVABLE METAL PARTS OF THE MECHANISM WHILE ACTIVATING REPEATEDLY. HEREAFTER LUBRICATE MINIMUM TWICE A YEAR. SEE ALSO SECTION H.



ESPAGNOLETTES

WITH SIDE BOLTS

IPA NO.s 23701-10 & 23715-24

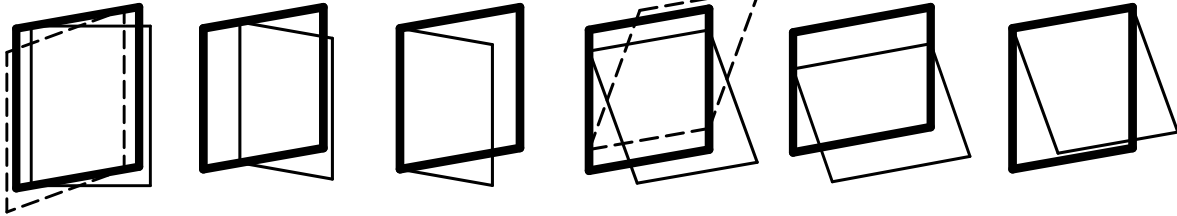

PREPARED FOR FRICTION STAY
12 MM SIDE BOLTS

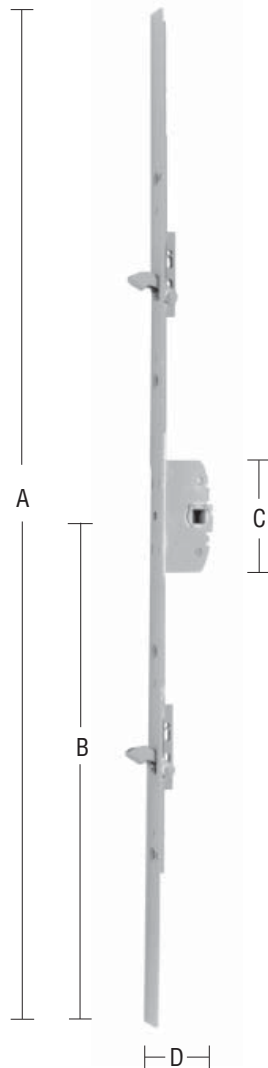

23701-24

ORDERING NO.					A MM	B MM	BACKSET MM	PIN MM	C MM	D MM	FACEPLATE MM	THICKNESS PLATE MM	SCREW	APPROX. WEIGHT KG / EACH
IPA NO.	MATERIAL	SURFACE	STANDARD PACKING IN BOXES OF 10 PIECES	SQUARE EDGES										
23701	1	6	21	1	600	300	25	8	66	34	16/17	2,5	4,0	0,30
23702	1	6	21	1	720	360	25	8	66	34	16/17	2,5	4,0	0,35
23703	1	6	21	1	820	410	25	8	66	34	16/17	2,5	4,0	0,40
23704	1	6	21	1	920	460	25	8	66	34	16/17	2,5	4,0	0,45
23705	1	6	21	1	1020	510	25	8	66	34	16/17	2,5	4,0	0,50
23706	1	6	21	1	1120	560	25	8	66	34	16/17	2,5	4,0	0,55
23707	1	6	21	1	1220	610	25	8	66	34	16/17	2,5	4,0	0,60
23708	1	6	21	1	1320	660	25	8	66	34	16/17	2,5	4,0	0,65
23709	1	6	21	1	1420	710	25	8	66	34	16/17	2,5	4,0	0,70
23710	1	6	21	1	1400	700	25	8	66	34	16/17	2,5	4,0	0,75
23715	1	6	21	1	600	300	28	8	66	37	16/17	2,5	4,0	0,30
23716	1	6	21	1	720	360	28	8	66	37	16/17	2,5	4,0	0,35
23717	1	6	21	1	820	410	28	8	66	37	16/17	2,5	4,0	0,40
23718	1	6	21	1	920	460	28	8	66	37	16/17	2,5	4,0	0,45
23719	1	6	21	1	1020	510	28	8	66	37	16/17	2,5	4,0	0,50
23720	1	6	21	1	1120	560	28	8	66	37	16/17	2,5	4,0	0,55
23721	1	6	21	1	1220	610	28	8	66	37	16/17	2,5	4,0	0,60
23722	1	6	21	1	1320	660	28	8	66	37	16/17	2,5	4,0	0,65
23723	1	6	21	1	1420	710	28	8	66	37	16/17	2,5	4,0	0,70
23724	1	6	21	1	1400	700	28	8	66	37	16/17	2,5	4,0	0,75

- CONSEALED FITTINGS
- IMPROVED SECURITY IN CLOSED POSITION
- USABLE FOR TOP HUNG WINDOWS ALSO
- CAN BE USED WITH FRICTION STAY NO.s 23810-21, EXTENTION PIECES NO.s 23580-97 AND CONNECTION PIECES NO.s 23782-90



FITTING INSTRUCTIONS

IPA NO.	L MM	A MM	B MM	D MM
23701 / 23715	600	300	140	12
23702 / 23716	720	360	140	12
23703 / 23717	820	410	190	12
23704 / 23718	920	460	240	12
23705 / 23719	1020	510	290	12
23706 / 23720	1120	560	340	12
23707 / 23721	1220	610	390	12
23708 / 23722	1320	670	440	12
23709 / 23723	1420	720	490	12
23710 / 23724	1400	700	540	12

FIG. 1

SHORTENING POSSIBILITIES:

WITHOUT FRICTION STAY:

130 MM AT THE TOP WITH SIDE BOLTS OUT.

130 MM AT THE BOTTOM WITH SIDE BOLTS IN.

WITH FRICTION STAY MOUNTED (TOP):

(TO MOUNT FRICTION STAY MIN. 60 MM HAS TO BE CUT OF)

110 MM AT THE TOP WITH SIDE BOLTS OUT.

130 MM AT THE BOTTOM WITH SIDE BOLTS IN.

WITH FRICTION STAY MOUNTED (BOTTOM):

(TO MOUNT FRICTION STAY MIN. 60 MM HAS TO BE CUT OF)

130 MM AT THE TOP WITH SIDE BOLTS OUT.

1100 MM AT THE BOTTOM WITH SIDE BOLTS IN.

IPA NO.s 23701 AND 23715 HAS SMALLER SHORTENING POSSIBILITIES.

FACE PLATE: 16/17 MM

USE SCREW NO. 4.

MAINTENANCE:

THE FITTINGS ARE NOT TO BE PAINTED. TEST THE OPERATION FROM TIME TO TIME.

WHEN MOUNTING - LUBRICATE THE PIVOT/ MOVABLE METAL PARTS OF THE MECHANISM WHILE ACTIVATING REPEATEDLY. HEREAFTER LUBRICATE MINIMUM TWICE A YEAR. SEE ALSO SECTION H.

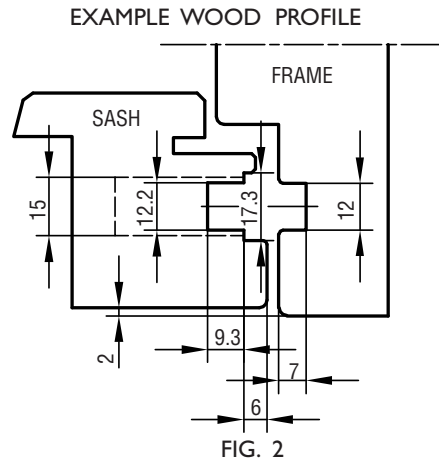
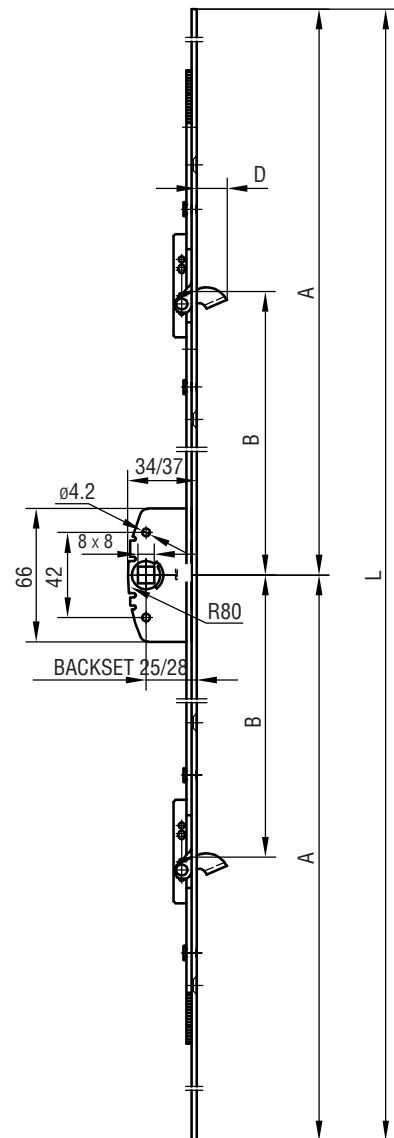

FIG. 2



IPA NO.s 23701-24

FIG. 3



ESPAGNOLETTES

WITH SIDE BOLTS

IPA NO.s 23745-54 & 23760-69

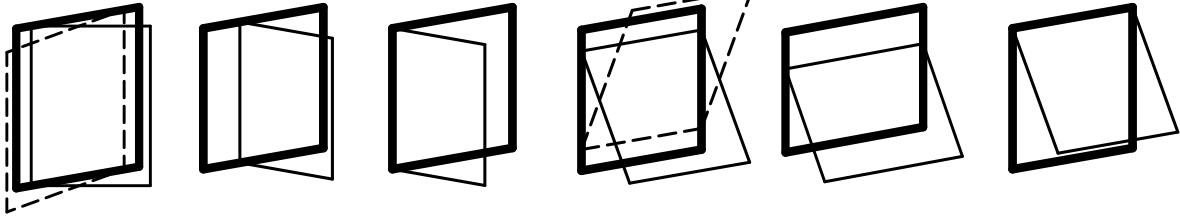

PREPARED FOR FRICTION STAY
15 MM SIDE BOLTS

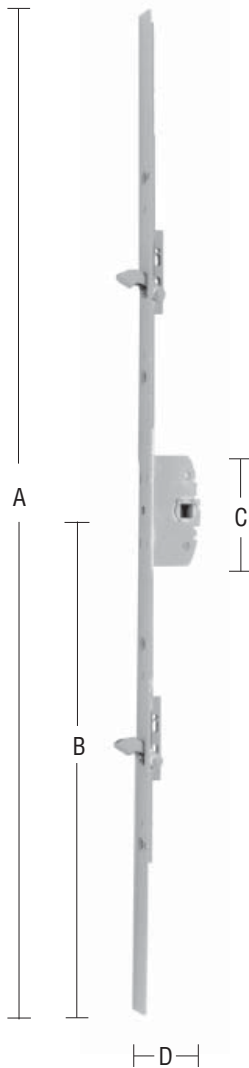

23745-69

ORDERING NO.					A MM	B MM	BACKSET MM	PIN MM	C MM	D MM	FACEPLATE MM	THICKNESS PLATE MM	SCREW	APPROX. WEIGHT KG / EACH
IPA NO.	MATERIAL	SURFACE		STANDARD PACKING IN BOXES OF 10 PIECES										
	STEEL	SQUARE EDGES	ELECTROPLATED											
23745	1	6	21	1	600	300	25	8	66	34	16/17	2,5	4,0	0,30
23746	1	6	21	1	720	360	25	8	66	34	16/17	2,5	4,0	0,35
23747	1	6	21	1	820	410	25	8	66	34	16/17	2,5	4,0	0,40
23748	1	6	21	1	920	460	25	8	66	34	16/17	2,5	4,0	0,45
23749	1	6	21	1	1020	510	25	8	66	34	16/17	2,5	4,0	0,50
23750	1	6	21	1	1120	560	25	8	66	34	16/17	2,5	4,0	0,55
23751	1	6	21	1	1220	610	25	8	66	34	16/17	2,5	4,0	0,60
23752	1	6	21	1	1320	660	25	8	66	34	16/17	2,5	4,0	0,65
23753	1	6	21	1	1420	710	25	8	66	34	16/17	2,5	4,0	0,70
23754	1	6	21	1	1400	700	25	8	66	34	16/17	2,5	4,0	0,75
23760	1	6	21	1	600	300	28	8	66	37	16/17	2,5	4,0	0,30
23761	1	6	21	1	720	360	28	8	66	37	16/17	2,5	4,0	0,35
23762	1	6	21	1	820	410	28	8	66	37	16/17	2,5	4,0	0,40
23763	1	6	21	1	920	460	28	8	66	37	16/17	2,5	4,0	0,45
23764	1	6	21	1	1020	510	28	8	66	37	16/17	2,5	4,0	0,50
23765	1	6	21	1	1120	560	28	8	66	37	16/17	2,5	4,0	0,55
23766	1	6	21	1	1220	610	28	8	66	37	16/17	2,5	4,0	0,60
23767	1	6	21	1	1320	660	28	8	66	37	16/17	2,5	4,0	0,65
23768	1	6	21	1	1420	710	28	8	66	37	16/17	2,5	4,0	0,70
23769	1	6	21	1	1400	700	28	8	66	37	16/17	2,5	4,0	0,75

- CONSEALED FITTINGS
- IMPROVED SECURITY IN CLOSED POSITION
- USABLE FOR TOP HUNG WINDOWS ALSO
- CAN BE USED WITH FRICTION STAY NO.s 23810-21, EXTENTION PIECES NO.s 23580-97 AND CONNECTION PIECES NO.s 23782-90



FITTING INSTRUCTIONS

IPA NO.	L MM	A MM	B MM	D MM
23745 / 23760	600	300	140	15
23746 / 23761	720	360	140	15
23747 / 23762	820	410	190	15
23748 / 23763	920	460	240	15
23749 / 23764	1020	510	290	15
23750 / 23765	1120	560	340	15
23751 / 23766	1220	610	390	15
23752 / 23767	1320	660	440	15
23753 / 23768	1420	710	490	15
23754 / 23769	1400	700	540	15

FIG. 1

SHORTENING POSSIBILITIES:

WITHOUT FRICTION STAY:

130 MM AT THE TOP WITH SIDE BOLTS OUT.
130 MM AT THE BOTTOM WITH SIDE BOLTS IN.

WITH FRICTION STAY MOUNTED (TOP):

(TO MOUNT FRICTION STAY MIN. 60 MM HAS TO BE CUT OF)
110 MM AT THE TOP WITH SIDE BOLTS OUT.
130 MM AT THE BOTTOM WITH SIDE BOLTS IN.

WITH FRICTION STAY MOUNTED (BOTTOM):

(TO MOUNT FRICTION STAY MIN. 60 MM HAS TO BE CUT OF)
130 MM AT THE TOP WITH SIDE BOLTS OUT.
110 MM AT THE BOTTOM WITH SIDE BOLTS IN.

IPA NO.s 23745 AND 23760 HAS SMALLER SHORTENING POSSIBILITIES.

FACE PLATE: 16/17 MM

USE SCREW NO. 4.

MAINTENANCE:

THE FITTINGS ARE NOT TO BE PAINTED. TEST THE OPERATION FROM TIME TO TIME.
WHEN MOUNTING - LUBRICATE THE PIVOT/ MOVABLE METAL PARTS OF THE MECHANISM WHILE ACTIVATING REPEATEDLY. HEREAFTER LUBRICATE MINIMUM TWICE A YEAR. SEE ALSO SECTION H.

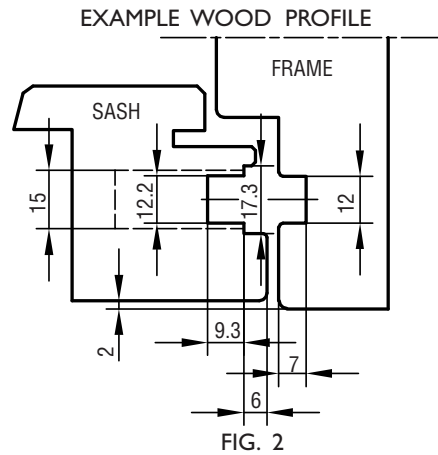
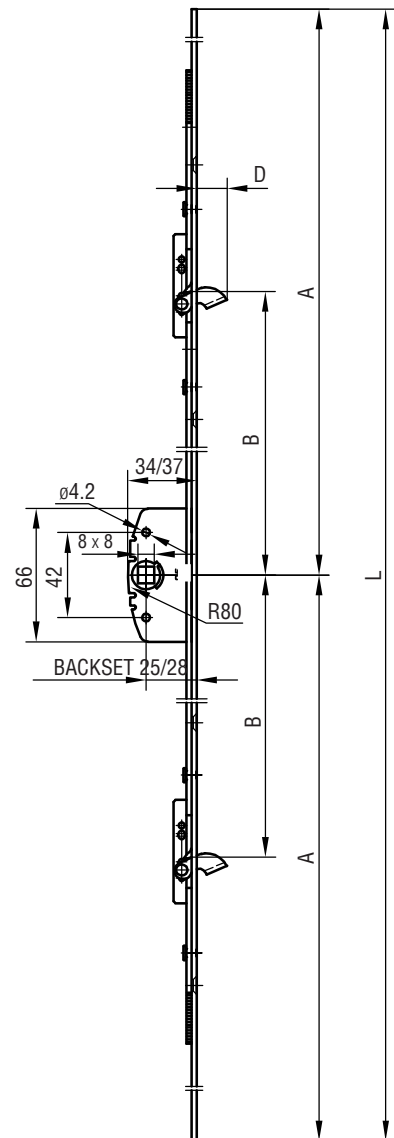

FIG. 2



IPA NO.s 23745-69

FIG. 3



ESPAGNOLETTES

WITH SIDE BOLTS

IPA NO.s 23841-44 & 23845-48

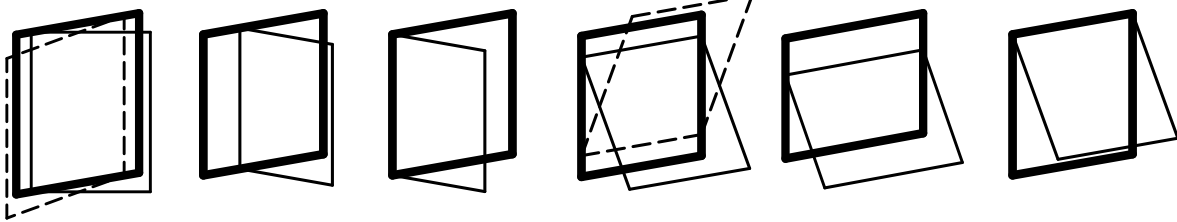

PREPARED FOR FRICTION STAY
12 MM SIDE BOLTS

ORDERING NO.					A MM	B MM	BACKSET MM	PIN MM	C MM	D MM	FACEPLATE MM	THICKNESS PLATE MM	SCREW	APPROX. WEIGHT KG / EACH
IPA NO.	MATERIAL	SURFACE		STANDARDPACKING IN BOXES OF 10 PIECES										
	STEEL	SQUARE EDGES	ELECTROPLATED											
23841	1	6	21	1	440	220	25	8	66	34	16/17	2,5	4,0	0,26
23842	1	6	21	1	520	250	25	8	66	34	16/17	2,5	4,0	0,31
23843	1	6	21	1	440	220	28	8	66	37	16/17	2,5	4,0	0,27
23844	1	6	21	1	520	250	28	8	66	37	16/17	2,5	4,0	0,32

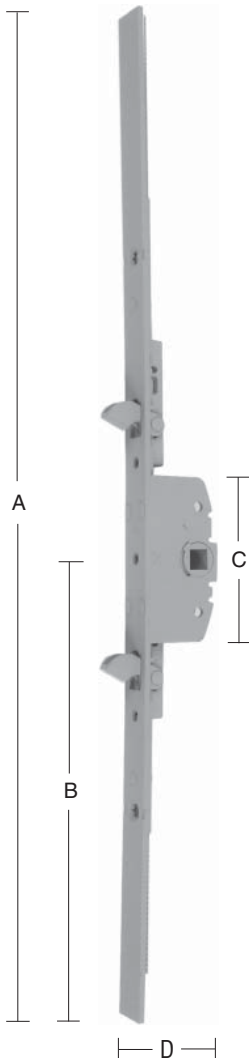

23841-48

PREPARED FOR FRICTION STAY
15 MM SIDE BOLTS

ORDERING NO.					A MM	B MM	BACKSET MM	PIN MM	C MM	D MM	FACEPLATE MM	THICKNESS PLATE MM	SCREW	APPROX. WEIGHT KG / EACH
IPA NO.	MATERIAL	SURFACE		STANDARDPACKING IN BOXES OF 10 PIECES										
	STEEL	SQUARE EDGES	ELECTROPLATED											
23845	1	6	21	1	440	220	25	8	66	34	16/17	2,5	4,0	0,26
23846	1	6	21	1	520	250	25	8	66	34	16/17	2,5	4,0	0,31
23847	1	6	21	1	440	220	28	8	66	37	16/17	2,5	4,0	0,27
23848	1	6	21	1	520	250	28	8	66	37	16/17	2,5	4,0	0,32

- CONSEALED FITTINGS
- IMPROVED SECURITY IN CLOSED POSITION
- USABLE FOR TOP HUNG WINDOWS ALSO
- CAN BE USED WITH FRICTION STAY NO.s 23810-21, EXTENTION PIECES NO.s 23580-97 AND CONNECTION PIECES NO.s 23782-90



FITTING INSTRUCTIONS

IPA NO.	L MM	A MM	B MM	C MM	D MM	E MM	F MM	G MM
23841	440	220	220	40	60	12	25	34
23842	520	250	270	90	110	12	25	34
23843	440	220	220	40	60	12	28	37
23844	520	250	270	90	110	12	28	37
23845	440	220	220	40	60	15	25	34
23846	520	250	270	90	110	15	25	34
23847	440	220	220	40	60	15	28	37
23848	520	250	270	90	110	15	28	37

FIG. 1

SHORTENING POSSIBILITIES FOR IPA NO. 23841+43+45+47:
WITHOUT FRICTION STAY:

- 70 MM AT THE TOP WITH SIDE BOLTS OUT.
- 90 MM AT THE BOTTOM WITH SIDE BOLTS IN.

FRICTION STAY AT THE TOP:

- 50 MM AT THE TOP WITH SIDE BOLTS OUT.
- 90 MM AT THE BOTTOM WITH SIDE BOLTS IN.

FRICTION STAY AT THE BOTTOM:

- 70 MM AT THE TOP WITH SIDE BOLTS OUT.
- 70 MM AT THE BOTTOM WITH SIDE BOLTS IN.

SHORTENING POSSIBILITIES FOR IPA NO. 23842+44+46+48:
WITHOUT FRICTION STAY:

- 70 MM AT THE TOP WITH SIDE BOLTS OUT.
- 70 MM AT THE BOTTOM WITH SIDE BOLTS IN.

FRICTION STAY AT THE TOP:

- 50 MM AT THE TOP WITH SIDE BOLTS OUT.
- 70 MM AT THE BOTTOM WITH SIDE BOLTS IN.

FRICTION STAY AT THE BOTTOM:

- 70 MM AT THE TOP WITH SIDE BOLTS OUT.
- 50 MM AT THE BOTTOM WITH SIDE BOLTS IN.

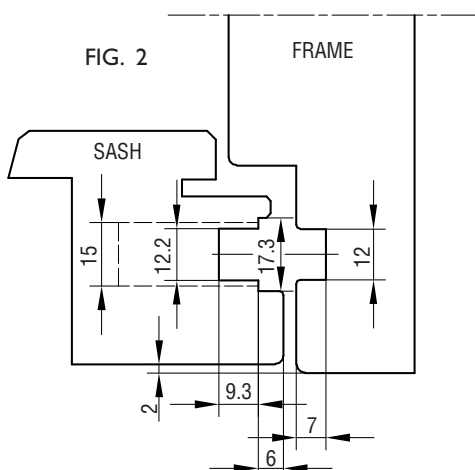

FIG. 2

FRAME

SASH

FACEPLATE: 16/17 MM

USE SCREW NO.

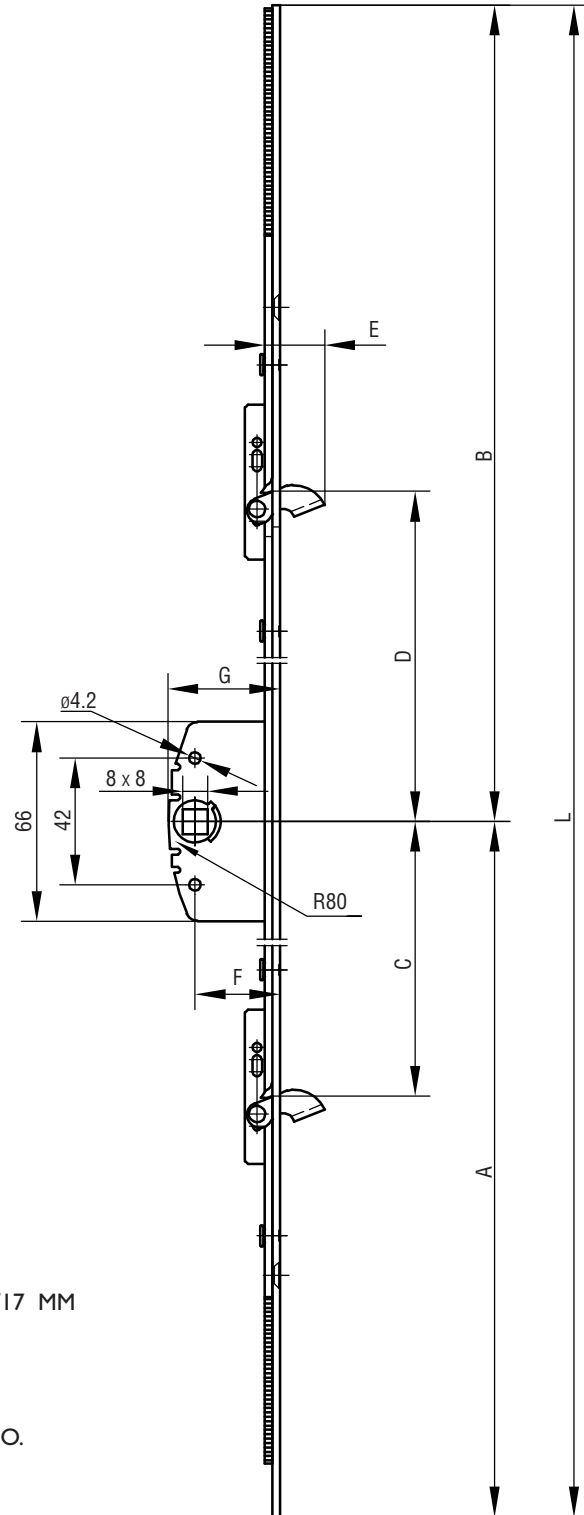

FIG. 3

MAINTENANCE:

THE FITTINGS ARE NOT TO BE PAINTED. TEST THE OPERATION FROM TIME TO TIME. WHEN MOUNTING - LUBRICATE THE PIVOT/MOVABLE METAL PARTS OF THE MECHANISM WHILE ACTIVATING REPEATEDLY. HEREAFTER LUBRICATE MINIMUM TWICE A YEAR. SEE ALSO SECTION H.



ESPAGNOLETTES

WITH SIDE BOLTS

IPA NO.s 23121-24

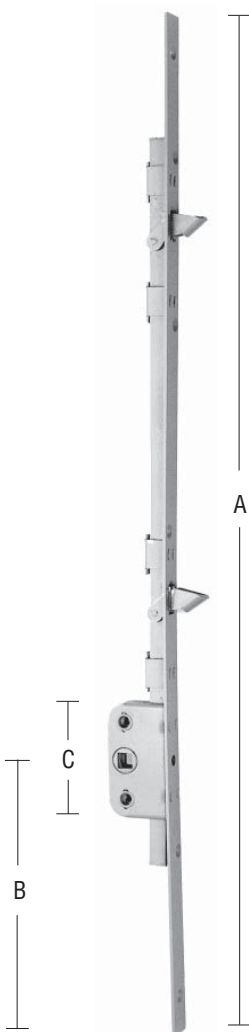
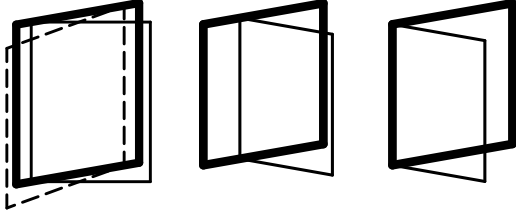

H-D-H
23121-24

ORDERING NO.					A MM	B MM	BACKSET MM	PIN MM	C MM	D MM	FACEPLATE MM	THICKNESS PLATE MM	THREADED NIPPLE FOR HANDLE MM	SCREW	APPROX. WEIGHT KG / EACH
IPA NO.	MATERIAL	SURFACE		STANDARD PACKING IN BOXES OF 10 PIECES											
	STEEL	SQUARE EDGES	ELECTROPLATED												
23121	1	6	21	1	550	150	25	8	63	35	17	2	5	3,0	0,38
23122	1	6	21	1	850	150	25	8	63	35	17	2	5	3,0	0,55
23123	1	6	21	1	1050	150	25	8	63	35	17	2	5	3,0	0,65
23124	1	6	21	1	1350	150	25	8	63	35	17	2	5	3,0	0,83

ACCESSORIES - SEE SECTION F

- CONSEALED FITTINGS
- IMPROVED SECURITY IN CLOSED POSITION
- 19 MM SIDE BOLTS



FITTING INSTRUCTIONS

IPA NO.	L MM	A MM	B MM	C MM	D MM	E MM BACKSET	F MM
23121	550	400	150	90	200	25	35
23122	850	700	150	90	500	25	35
23123	1050	900	150	90	700	25	35
23124	1350	1200	150	90	1000	25	35

FIG. 1

FACEPLATE: 17 MM

SHORTENING POSSIBILITIES:

50 MM AT EACH END

USE SCREW NO.

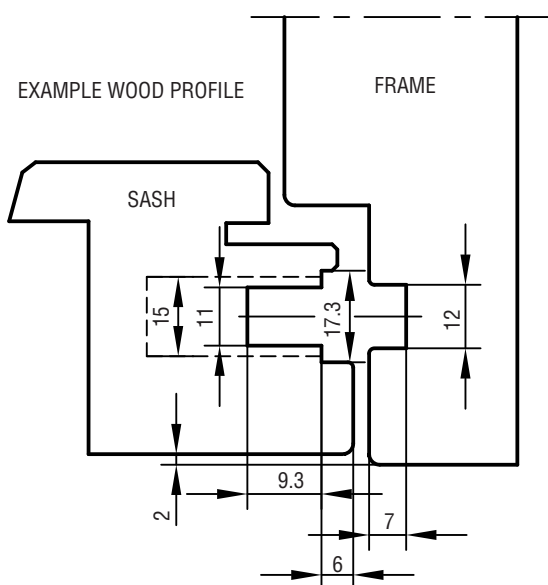

FIG. 2

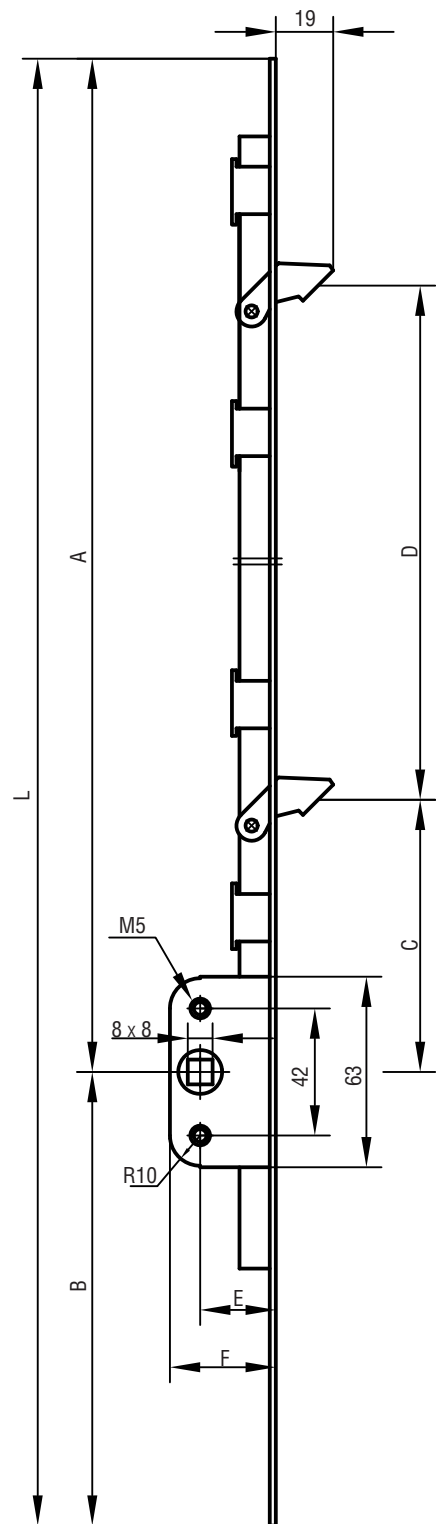

FIG. 3

MAINTENANCE:

THE FITTINGS ARE NOT TO BE PAINTED. TEST THE OPERATION FROM TIME TO TIME. WHEN MOUNTING - LUBRICATE THE PIVOT/MOVABLE METAL PARTS OF THE MECHANISM WHILE ACTIVATING REPEATEDLY. HEREAFTER LUBRICATE MINIMUM TWICE A YEAR. SEE ALSO SECTION H.



ESPAGNOLETTES

WITH SIDE BOLTS FOR PATIO DOORS

IPA NO.s 23551-53

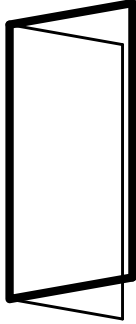

ORDERING NO.					L MM	A MM	B MM	C MM	D MM	E MM	BACKSET MM	PIN MM	FACEPLATE MM	THICKNESS PLATE MM	SCREW	APPROX. WEIGHT KG/SET
IPA NO.	MATERIAL	SURFACE		STANDARD PACKING IN BOXES OF 5 PIECES.												
	STEEL	SQUARE EDGES	ELECTROPLATED													
23551	1	6	21	1	2110	270	1005	1050	1540	17	40	8	16/17	2,5	4,0	1,08
23553	1	6	21	1	2110	270	1005	1050	1750	17	40	8	16/17	2,5	4,0	1,10

ACCESSORIES - SEE SECTION F

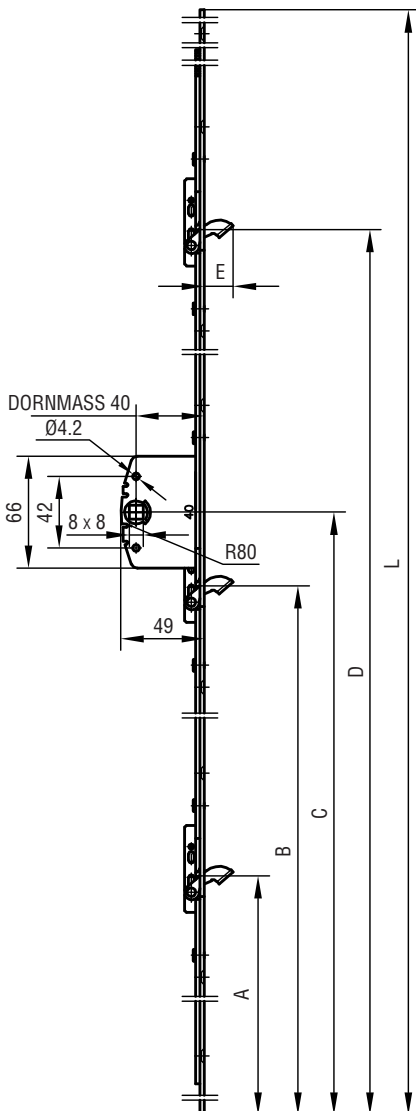

23551-53

- CONSEALED FITTINGS
- IMPROVED SECURITY IN CLOSED POSITION
- 17 MM SIDE BOLTS
- CAN BE USED WITH FRICTION STAY NO.s 23820-23, EXTENTION PIECES NO.s 23583 AND 23790 AND CONNECTION PIECES NO.s 23782-90



FITTING INSTRUCTIONS

IPA NO.	L MM	A MM	B MM	C MM	D MM	E MM	FACEPLATE MM
23551	2110	270	1005	1050	1540	17	16/17
23553	2110	270	1005	1050	1750	17	16/17

FIG. 1

SHORTENING POSSIBILITIES (AT THE TOP):

IPA NO. 23551: WITHOUT RESTRICTOR:
475 MM WITH SIDEBOLTS OUT.

WITH RESTRICTOR:
MIN. 235 MM WITH SIDEBOLTS OUT.
MAX. 455 MM WITH SIDEBOLTS OUT.

IPA NO. 23553: WITHOUT RESTRICTOR:
255 MM WITH SIDEBOLTS OUT.

WITH RESTRICTOR:
MIN. 65 MM WITH SIDEBOLTS OUT.
MAX. 235 MM WITH SIDEBOLTS OUT.

USE SCREW NO. 4.0

MAINTENANCE:

THE FITTINGS ARE NOT TO BE PAINTED. TEST THE OPERATION FROM TIME TO TIME. WHEN MOUNTING - LUBRICATE THE PIVOT/ MOVABLE METAL PARTS OF THE MECHANISM WHILE ACTIVATING REPEATEDLY. HEREAFTER LUBRICATE MINIMUM TWICE A YEAR. SEE ALSO SECTION H.

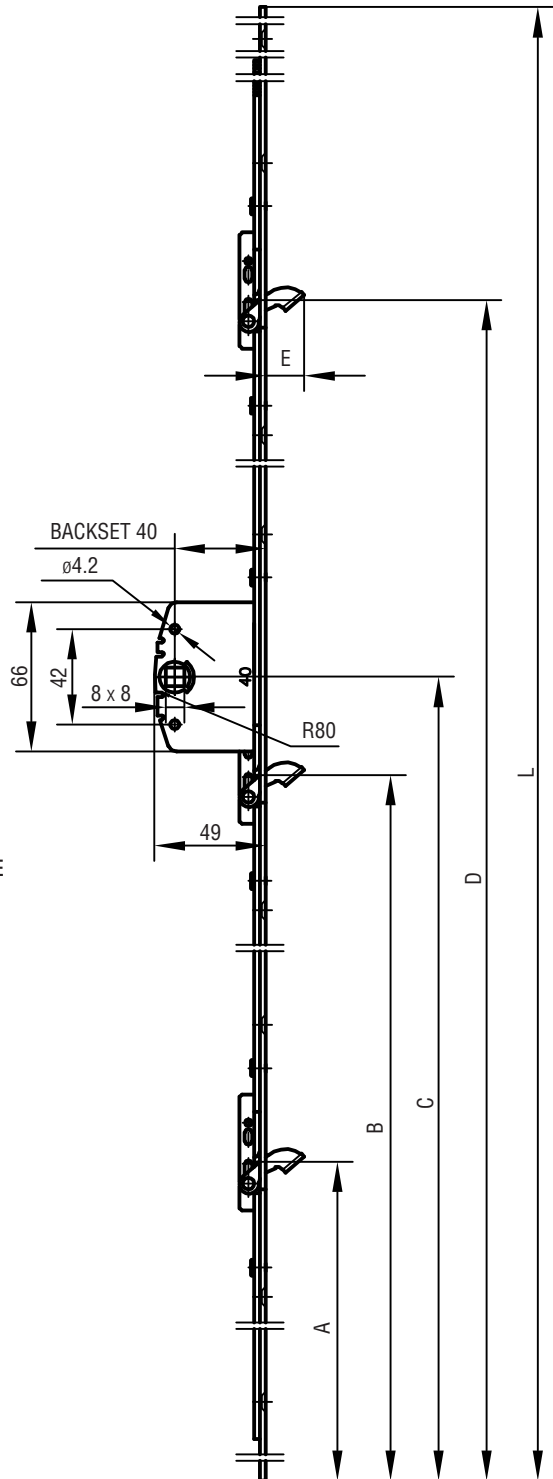

FIG. 3

EXAMPLE WOOD PROFILE

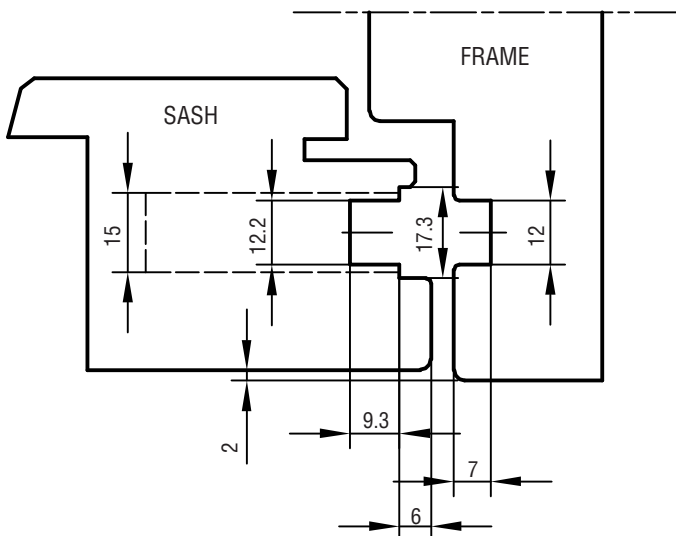
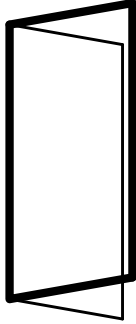

FIG. 2



ESPAGNOLETTES 2-PARTS WITH SIDE BOLTS FOR PATIO DOORS IPA NO. 23461 & IPA NO.s 23462-67



ESPAGNOLETTE LOWER PART

ORDERING NO.															
IPA NO.	MATERIAL	SURFACE			STANDARD PACKING IN BOXES OF 25 PIECES	A MM	B MM	C MM	D MM	BACKSET MM	PIN MM	FACEPLATE MM	THICKNESS PLATE MM	SCREW	APPROX.WEIGHT KG / EACH
	STEEL	SQUARE EDGES	ELECTROPLATED												
23461	1	6	21	1	1230	270	1005	1050	40	8	16	2,5	4,0	0,7	

EXTENTION PIECES UPPER PART

ORDERING NO.												
IPA NO.	MATERIAL	SURFACE			STANDARD PACKING IN BOXES OF 10 PIECES	E MM	F MM	FACEPLATE MM	THICKNESS PLATE MM	SCREW	APPROX.WEIGHT KG / EACH	
	STEEL	SQUARE EDGES	ELECTROPLATED									
23462	1	6	21	1	520	270	16	2,5	4,0	0,26		
23463	1	6	21	1	670	270	16	2,5	4,0	0,32		
23464	1	6	21	1	820	270	16	2,5	4,0	0,38		
23465	1	6	21	1	970	270	16	2,5	4,0	0,44		
23466	1	6	21	1	1120	270	16	2,5	4,0	0,50		
23467	1	6	21	1	1270	270	16	2,5	4,0	0,56		

ACCESSORIES - SEE SECTION F

- CONSEALED FITTINGS
- IMPROVED SECURITY IN CLOSED POSITION
- 17 MM SIDE BOLTS
- CAN BE FITTED TO ANY DOORS SIZE ON SIGHT
- CAN BE USED WITH FRICTION STAY NO.s 23820-23 AND EXTENTION PIECES NO.s 23581, 23584, 23587, 23590, 23593 & 23596 (FACEPLATE 16/17 MM) - SEE SECTION F

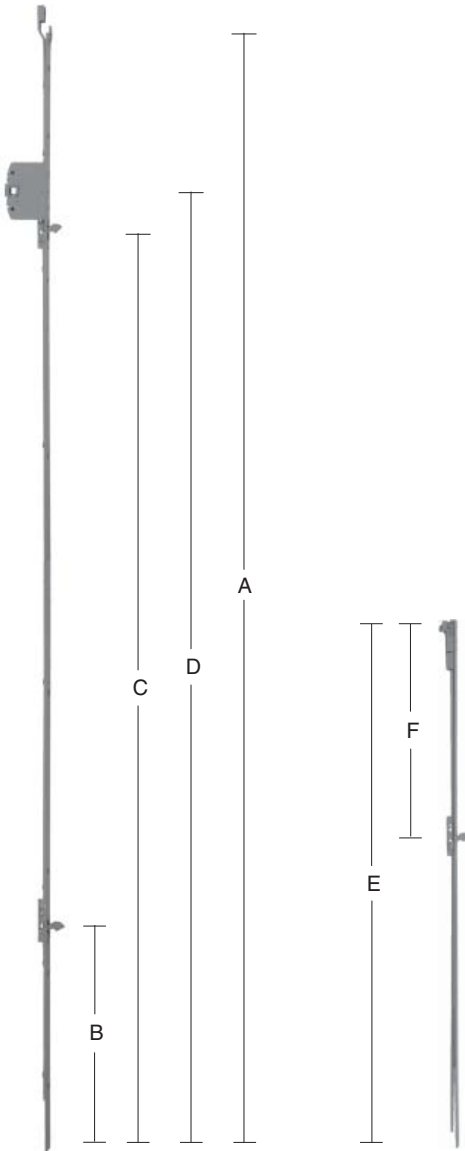

23461

23462-67



FITTING INSTRUCTIONS

IPA NO.	A MM	B MM	C MM	D MM	E MM	F MM	FACEPLATE MM
23461	1230	270	1005	1050	17	270	16

FIG. 1

SHORTENING POSSIBILITIES:

THE TOP PARTS OF THE ESPAGNOLETTE ARE AVAILABLE IN 6 LENGTHS 520, 670, 820, 970, 1120 & 1270 MM. THEY CAN ALL BE SHORTENED UP TO 150 MM, WHICH GIVES THE POSSIBILITY OF ESPAGNOLETES FROM 1600 - 2500 MM.

USE SCREW NO. 4,0.

TO ENSURE THE FUNCTION OF THE ESPAGNOLETTE, PLEASE MAKE SURE WHEN MOUNTING THAT THE FACEPLATE IS NOT DEFORMED.

MAINTENANCE:

THE FITTINGS ARE NOT TO BE PAINTED. TEST THE OPERATION FROM TIME TO TIME. WHEN MOUNTING - LUBRICATE THE PIVOT/MOVABLE METAL PARTS OF THE MECHANISM WHILE ACTIVATING REPEATEDLY. HEREAFTER LUBRICATE MINIMUM TWICE A YEAR. SEE ALSO SECTION

EXAMPLE WOOD PROFILE

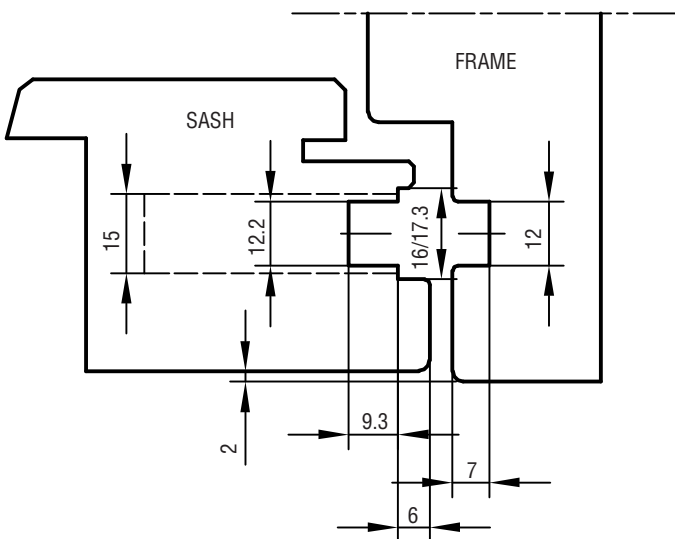

FIG. 2

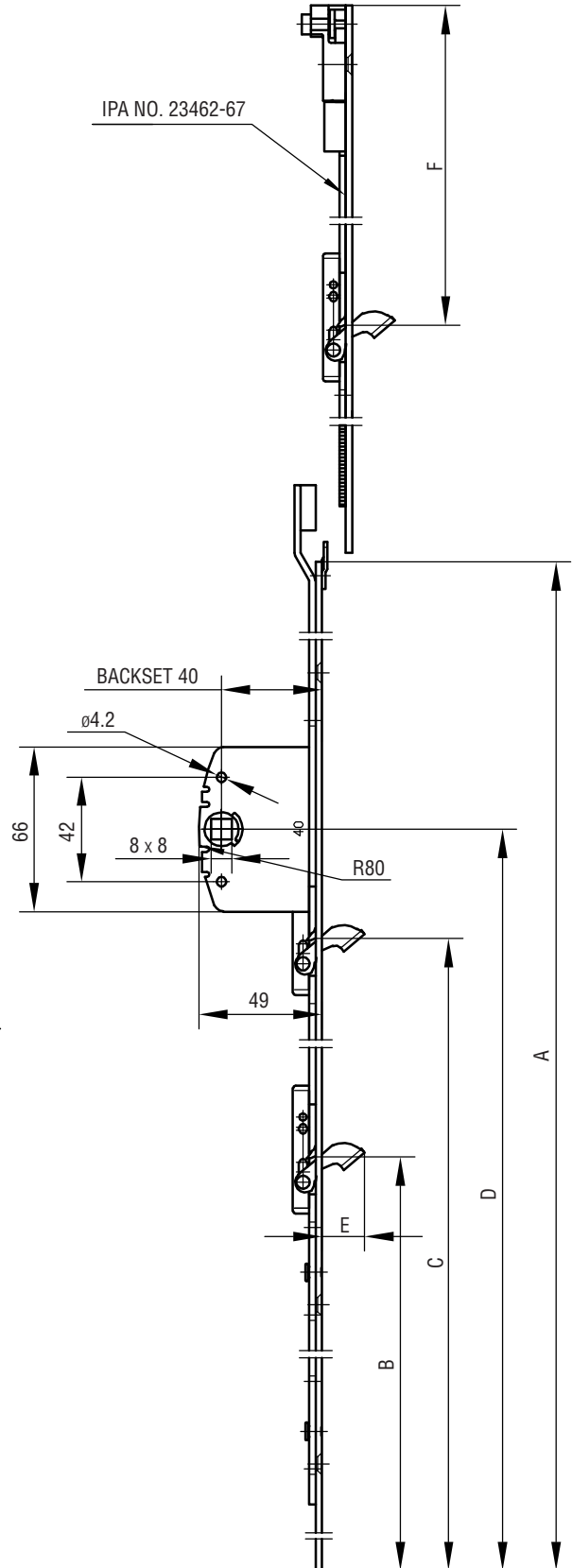
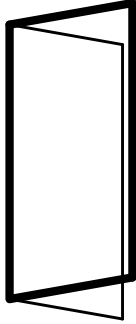

FIG. 3



ESPAGNOLETTES 2-PARTS WITH SIDE BOLTS FOR PATIO DOORS IPA NO. 23481 & IPA NO.s 23482-87



ESPAGNOLETTE LOWER PART

ORDERING NO.					A MM	B MM	C MM	D MM	BACKSET MM	PIN MM	FACEPLATE MM	THICKNESS PLATE MM	SCREW	APPROX. WEIGHT KG / EACH
IPA NO.	MATERIAL	SURFACE		STANDARD PACKING IN BOXES OF 25 PIECES										
	STEEL	SQUARE EDGES	ELECTROPLATED											
23481	1	6	21	1	1230	200	1074	1000	40	8	16	2,5	4,0	0,7

EXTENTION PIECES UPPER PART

ORDERING NO.					E MM	F MM	FACEPLATE MM	THICKNESS PLATE MM	SCREW	APPROX. WEIGHT KG / EACH
IPA NO.	MATERIAL	SURFACE		STANDARD PACKING IN BOXES OF 10 PIECES						
	STEEL	SQUARE EDGES	ELECTROPLATED							
23482	1	6	21	1	520	200	16	2,5	4,0	0,26
23483	1	6	21	1	670	200	16	2,5	4,0	0,32
23484	1	6	21	1	820	200	16	2,5	4,0	0,38
23485	1	6	21	1	970	200	16	2,5	4,0	0,44
23486	1	6	21	1	1120	200	16	2,5	4,0	0,50
23487	1	6	21	1	1270	200	16	2,5	4,0	0,56

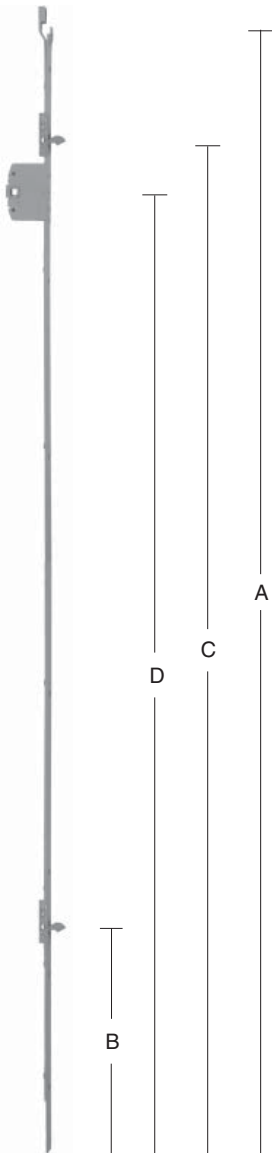

23481

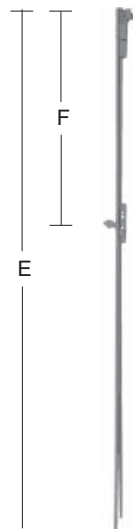

23482-87

ACCESSORIES - SEE SECTION F

- CONSEALED FITTINGS
- IMPROVED SECURITY IN CLOSED POSITION
- 17 MM SIDE BOLTS
- CAN BE FITTED TO ANY DOORS SIZE ON SIGHT
- CAN BE USED WITH FRICTION STAY NO.s 23820-23 AND EXTENTION PIECES NO.s 23581, 23584, 23587, 23590, 23593 & 23596 (FACEPLATE 16/17 MM) - SEE SECTION F



FITTING INSTRUCTIONS

IPA NO.	A MM	B MM	C MM	D MM	E MM	F MM	FACEPLATE MM
23481	1230	200	1074	1000	17	200	16

FIG. 1

SHORTENING POSSIBILITIES:

THE TOP PARTS OF THE ESPAGNOLETTE ARE AVAILABLE IN 6 LENGTHS 520, 670, 820, 970, 1120 & 1270 MM. THEY CAN ALL BE SHORTENED UP TO 150 MM, WHICH GIVES THE POSSIBILITY OF ESPAGNOLETES FROM 1600 - 2500 MM.

USE SCREW NO. 4,0.

TO ENSURE THE FUNCTION OF THE ESPAGNOLETTE, PLEASE MAKE SURE WHEN MOUNTING THAT THE FACEPLATE IS NOT DEFORMED.

MAINTENANCE:

THE FITTINGS ARE NOT TO BE PAINTED. TEST THE OPERATION FROM TIME TO TIME. WHEN MOUNTING - LUBRICATE THE PIVOT/MOVABLE METAL PARTS OF THE MECHANISM WHILE ACTIVATING REPEATEDLY. HEREAFTER LUBRICATE MINIMUM TWICE A YEAR. SEE ALSO SECTION

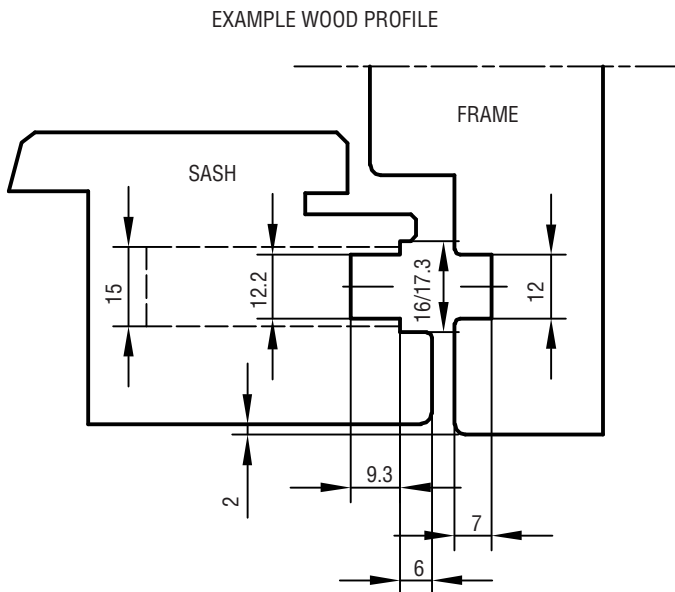

FIG. 2

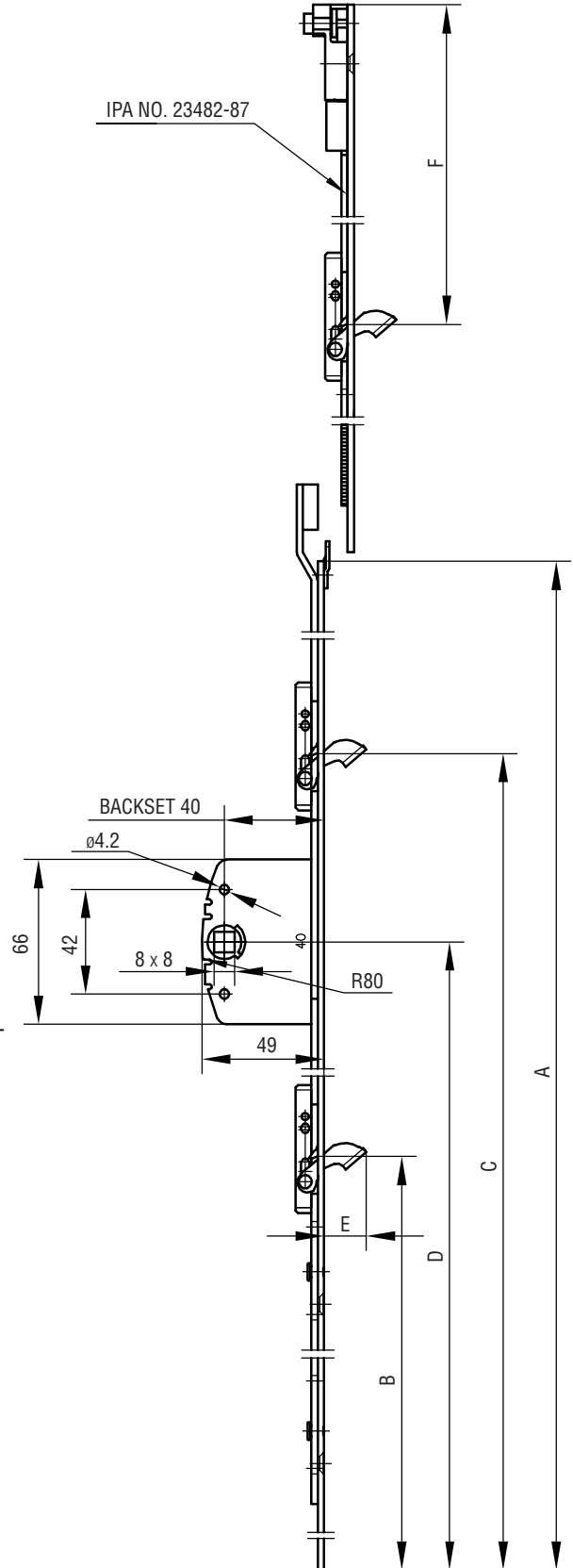
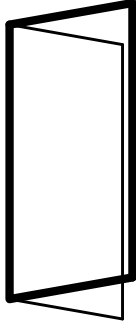

FIG. 3



ESPAGNOLETTES 2-PARTS WITH SIDE BOLTS FOR PATIO DOORS IPA NO. 23498 & IPA NO.s 23482-87



ESPAGNOLETTE LOWER PART

ORDERING NO.					A MM	B MM	C MM	D MM	BACKSET MM	PIN MM	FACEPLATE MM	THICKNESS PLATE MM	SCREW	APPROX.WEIGHT KG / EACH
IPA NO.	MATERIAL	SURFACE		STANDARD PACKING IN BOXES OF 25 PIECES										
	STEEL	SQUARE EDGES	ELECTROPLATED											
23498	1	6	21	1	1230	200	935	1000	40	8	16	2,5	4,0	0,7

EXTENTION PIECES UPPER PART

ORDERING NO.					E MM	F MM	FACEPLATE MM	THICKNESS PLATE MM	SCREW	APPROX.WEIGHT KG / EACH
IPA NO.	MATERIAL	SURFACE		STANDARD PACKING IN BOXES OF 10 PIECES						
	STEEL	SQUARE EDGES	ELECTROPLATED							
23482	1	6	21	1	520	200	16	2,5	4,0	0,26
23483	1	6	21	1	670	200	16	2,5	4,0	0,32
23484	1	6	21	1	820	200	16	2,5	4,0	0,38
23485	1	6	21	1	970	200	16	2,5	4,0	0,44
23486	1	6	21	1	1120	200	16	2,5	4,0	0,50
23487	1	6	21	1	1270	200	16	2,5	4,0	0,56

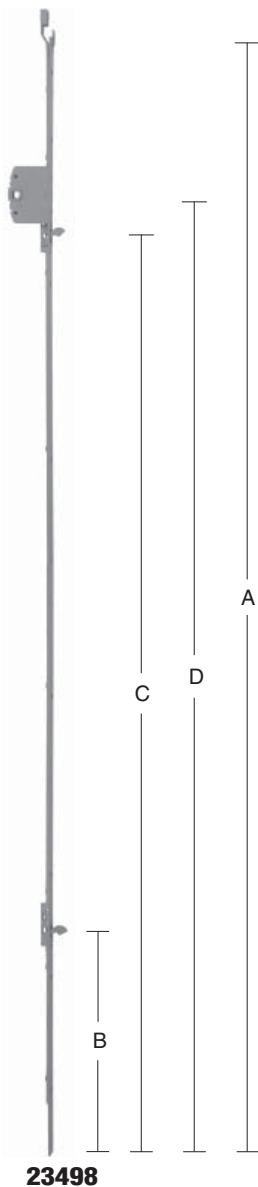

ACCESSORIES - SEE SECTION F

- CONSEALED FITTINGS
- IMPROVED SECURITY IN CLOSED POSITION
- 17 MM SIDE BOLTS
- CAN BE FITTED TO ANY DOORS SIZE ON SIGHT
- CAN BE USED WITH FRICTION STAY NO.s 23820-23 AND EXTENTION PIECES NO.s 23581, 23584, 23587, 23590, 23593 & 23596 (FACEPLATE 16/17 MM) - SEE SECTION F



FITTING INSTRUCTIONS

IPA NO.	A MM	B MM	C MM	D MM	E MM	F MM	FACEPLATE MM
23498	1230	200	935	1000	17	200	16

FIG. 1

SHORTENING POSSIBILITIES:

THE TOP PARTS OF THE ESPAGNOLETTE ARE AVAILABLE IN 6 LENGTHS 520, 670, 820, 970, 1120 & 1270 MM. THEY CAN ALL BE SHORTENED UP TO 150 MM, WHICH GIVES THE POSSIBILITY OF ESPAGNOLETES FROM 1600 - 2500 MM.

USE SCREW NO. 4,0.

TO ENSURE THE FUNCTION OF THE ESPAGNOLETTE, PLEASE MAKE SURE WHEN MOUNTING THAT THE FACEPLATE IS NOT DEFORMED.

MAINTENANCE:

THE FITTINGS ARE NOT TO BE PAINTED. TEST THE OPERATION FROM TIME TO TIME. WHEN MOUNTING - LUBRICATE THE PIVOT/MOVABLE METAL PARTS OF THE MECHANISM WHILE ACTIVATING REPEATEDLY. HEREAFTER LUBRICATE MINIMUM TWICE A YEAR. SEE ALSO SECTION

EXAMPLE WOOD PROFILE

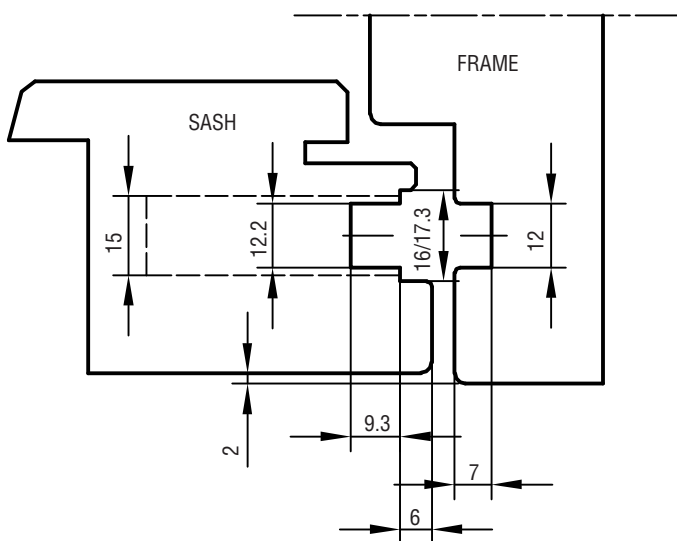

FIG. 2

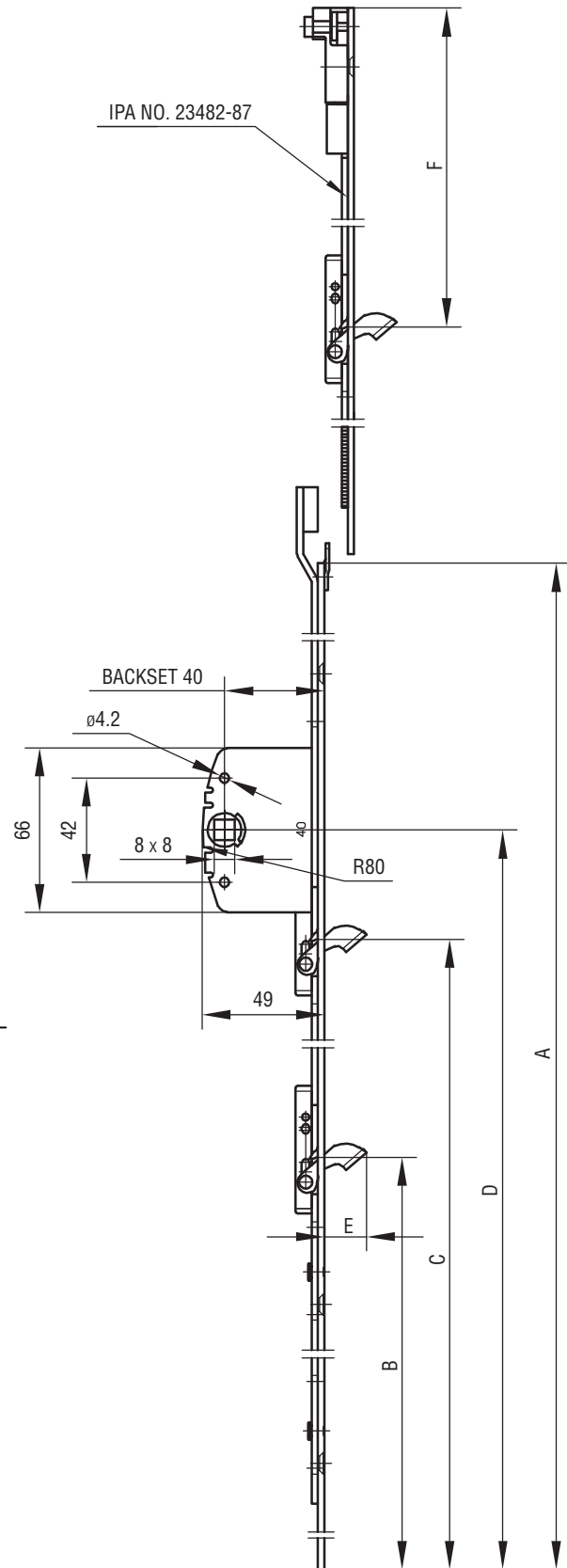

FIG. 3



ESPAGNOLETTES

WITH SIDE BOLTS

IPA NO.s 23131-34

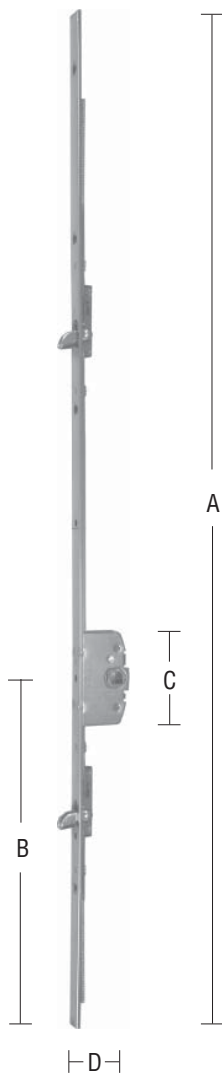
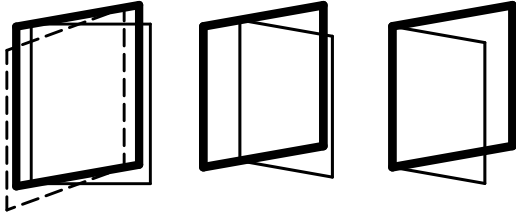

23131-34

ORDERING NO.					A MM	B MM	BACKSET MM	PIN MM	C MM	D MM	FACEPLATE MM	THICKNESS PLATE MM	SCREW	APPROX. WEIGHT KG / EACH
IPA NO.	MATERIAL	SURFACE		STANDARD PACKING IN BOXES OF 10 PIECES										
	STEEL	SQUARE EDGES	ELECTROPLATED											
23131	1	6	21	1	720	250	28	8	66	37	16	2,5	4,0	0,35
23132	1	6	21	1	920	250	28	8	66	37	16	2,5	4,0	0,45
23133	1	6	21	1	1120	250	28	8	66	37	16	2,5	4,0	0,55
23134	1	6	21	1	1320	250	28	8	66	37	16	2,5	4,0	0,65

ACCESSORIES - SEE SECTION F

- TO BE USED WHERE LOW HANDLE HEIGHT IS REQUIRED - FROM 160 MM FROM BOTTOM OF SASH
- CONSEALED FITTINGS
- IMPROVED SECURITY IN CLOSED POSITION
- CAN BE USED WITH FRICTION STAY NO.s 23810-21, EXTENTION PIE-
- CES NO.s 23580-97 AND CONNECTION PIECES NO.s 23782-90



FITTING INSTRUCTIONS

IPA NO.	L MM	A MM	B MM	C MM	D MM	E MM	F MM	G MM
23131	720	250	470	90	250	15	28	37
23132	920	250	670	90	450	15	28	37
23133	1120	250	870	90	650	15	28	37
23134	1320	250	1070	90	850	15	28	37

FIG. 1

SHORTENING POSSIBILITIES FOR IPA NO. 23131-34:

WITHOUT FRICTION STAY:

- 130 MM AT THE TOP WITH SIDE BOLTS OUT.
- 90 MM AT THE BOTTOM WITH SIDE BOLTS IN.

FRICTION STAY AT THE TOP:

- (TO MOUNT FRICTION STAY MIN. 60 MM HAS TO BE CUT OF)
- 60 - 110 MM AT THE TOP WITH SIDE BOLTS OUT.
- 90 MM AT THE BOTTOM WITH SIDE BOLTS IN.

FRICTION STAY AT THE BOTTOM:

- 130 MM AT THE TOP WITH SIDE BOLTS OUT.
- 70 MM AT THE BOTTOM WITH SIDE BOLTS IN.

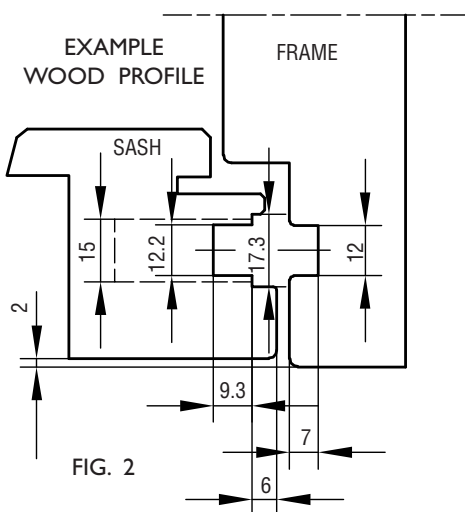

FIG. 2

USE SCREW NO. 4.0

FACEPLATE: 16/17 MM

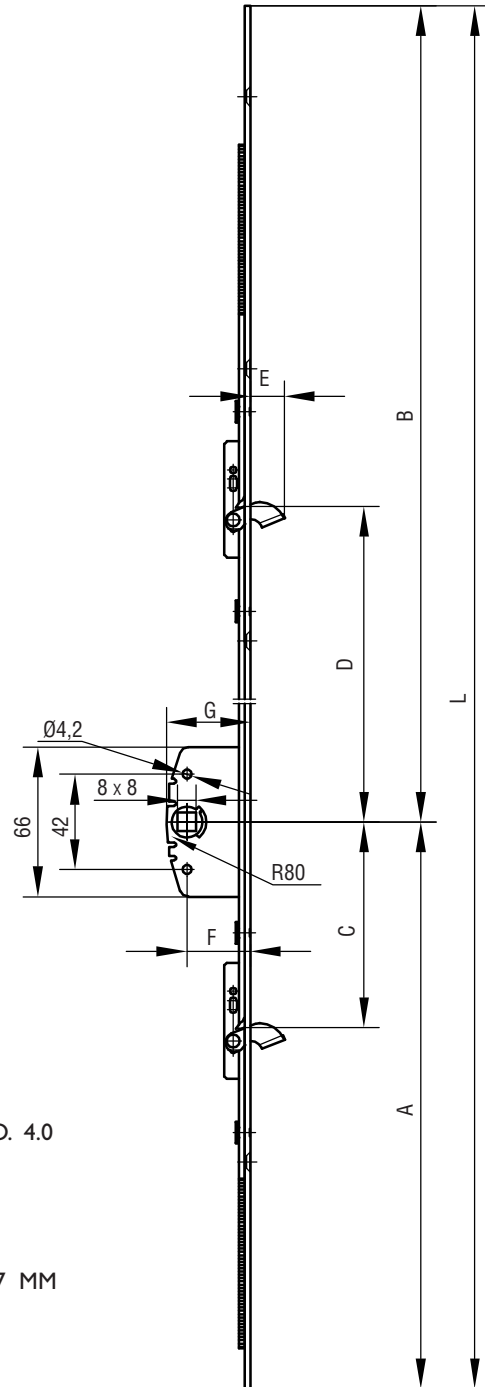

FIG. 3

MAINTENANCE:

THE FITTINGS ARE NOT TO BE PAINTED. TEST THE OPERATION FROM TIME TO TIME. WHEN MOUNTING - LUBRICATE THE PIVOT/MOVABLE METAL PARTS OF THE MECHANISM WHILE ACTIVATING REPEATEDLY. HEREAFTER LUBRICATE MINIMUM TWICE A YEAR. SEE ALSO SECTION H.



ESPAGNOLETTES WITH MUSHROOM HEAD BOLTS IPA NO.s 63051-60

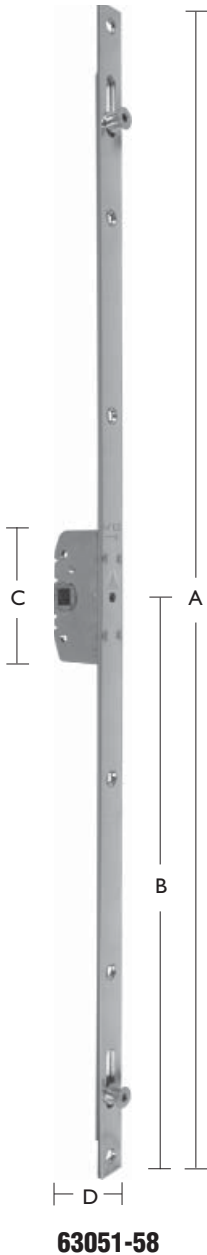
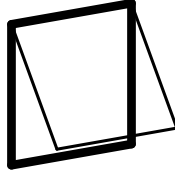
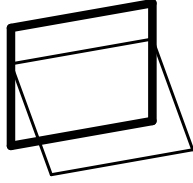
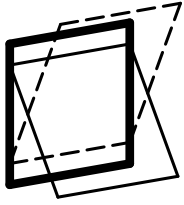

ORDERING NO.					A MM	B MM	BACKSET MM	FOR PIN MM	C MM	D MM	FACEPLATE MM	THICKNESS PLATE MM	SCREW	WEIGHT APPROX. KGS / 100 PCS.
IPA NO.	MATERIAL	W/O SPECIFICATION	SURFACE											
	STEEL		ELECTROPLATED	INDUSTRY PACKING IN BOXES OF 25 PCS.										
63051	1	0	21	2	300	150	25	8	66	34	16	2,5	4,0	0,20
63052	1	0	21	2	400	200	25	8	66	34	16	2,5	4,0	0,24
63054	1	0	21	2	600	300	25	8	66	34	16	2,5	4,0	0,34
63056	1	0	21	2	800	400	25	8	66	34	16	2,5	4,0	0,44
63058	1	0	21	2	1000	500	25	8	66	34	16	2,5	4,0	0,54

- 16 MM FACEPLATE
- CONSEALED FITTINGS
- IMPROVED SECURITY IN CLOSED POSITION
- GUIDE PIN IPA NO. 63081 - IS OPTIONAL
- ADJUSTABLE MUSHROOM HEAD BOLTS

RECEIVERS IPA NO. 23190-92 - SEE SECTION F.

GUIDE PIN



ORDERING NO.								
IPA NR.	MATERIAL	W/O SPECIFICATION	SURFACE		A MM	HEIGHT MM	SCREW	WEIGHT APPROX. KGS / 100 PCS.
	PLASTIC		GRAPHITE	INDUSTRY PACKING IN BOXES OF 100 PCS.				
63081	9	0	57	2	10	2,5	4,0	0,05



FITTING INSTRUCTIONS

IPA NO.	L MM	A MM
63051	300	195
63052	400	295
63054	600	495
63056	800	695
63058	1000	895
63060	1200	1095

FIG. 1

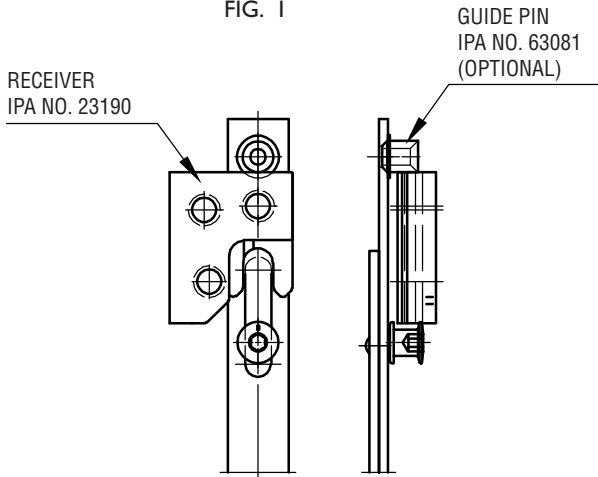

FIG. 4

WHEN USING IPA GUIDE PIN NO. 63081,
THE PIN MUST BE MOUNTED IN THE SCREWHOLE
TO THE RIGHT OF THE RIGHT LOCKING POINT
(SEEN FROM THE OUTSIDE)

EXAMPLE WOOD PROFILE

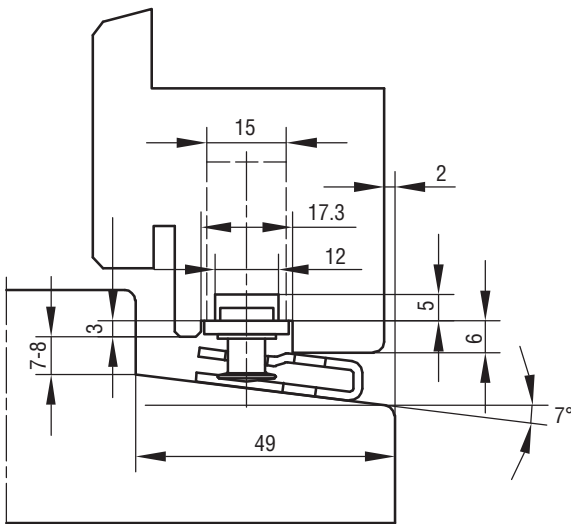

FIG. 2

SHOWN WITH RECEIVER IPA NO. 23190

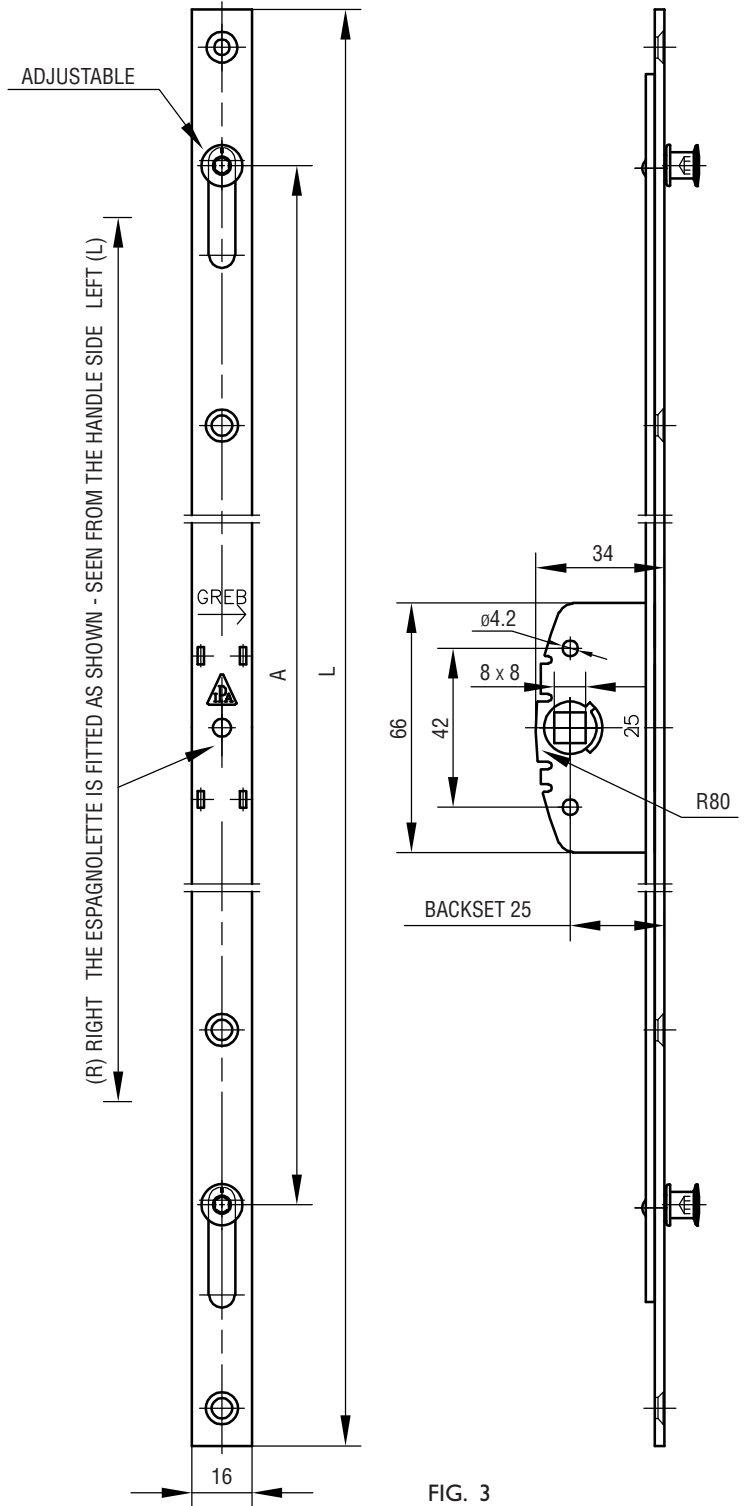

FIG. 3

USE SCREW NO. 4.0.

MAINTENANCE:

THE FITTINGS ARE NOT TO BE PAINTED. TEST THE OPERATION FROM TIME TO TIME. WHEN MOUNTING - LUBRICATE THE PIVOT/MOVABLE METAL PARTS OF THE MECHANISM WHILE ACTIVATING REPEATEDLY. HERAFTER LUBRICATE MINIMUM TWICE A YEAR.



FRICTION STAYS AND FRAME FIXTURES

IPA NO.s 23810-18, 23797-99 & 23801-03

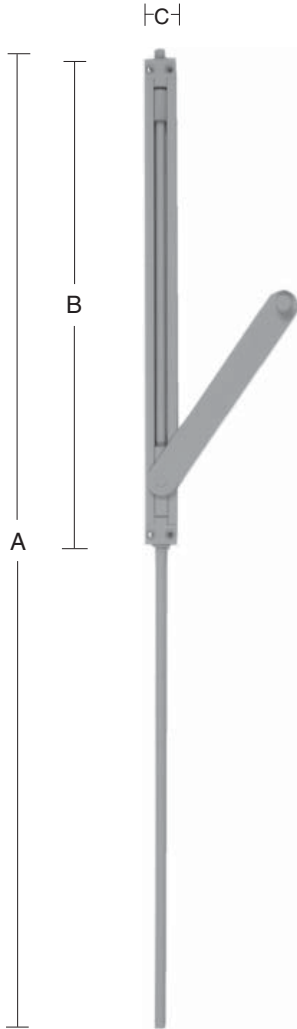

ORDERING NO.					A MM	B MM	SASH WIDTH MM	C MM	SCREW	APPROX. WEIGHT KG / EACH
IPA NO.	MATERIAL	SURFACE		STANDARD PACKING IN BOXES OF 10 PIECES						
	STEEL	WITHOUT SPECIFICATION	ELECTROPLATED							
23810	1	0	21	1	500	250	330-480	16	3,0	0,18
23811	1	0	21	1	650	330	481-690	16	3,0	0,25
23812	1	0	21	1	750	435	691-900	16	3,0	0,34
23813	1	0	21	1	1025	465	901-1100	16	3,0	0,43
23815	1	0	21	1	500	250	330-480	16	3,0	0,18
23816	1	0	21	1	650	330	481-690	16	3,0	0,25
23817	1	0	21	1	750	435	691-900	16	3,0	0,34
23818	1	0	21	1	1025	465	901-1100	16	3,0	0,43

23810-13: TO BE USED IN TOP SASH
23815-18: TO BE USED IN BOTTOM SASH

23810-21

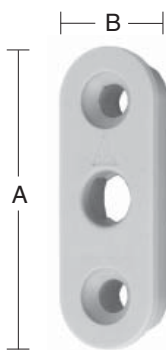
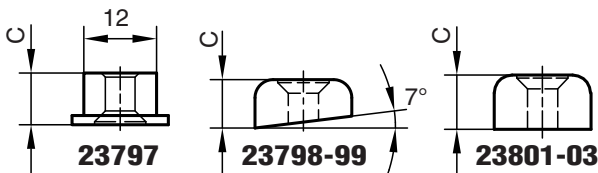

23797



23798-99 + 23801-03

ORDERING NO.					A MM	B MM	C MM	SCREW	WEIGHT APPROX. KGS / 100 PCS.	
IPA NR.	MAT.	SURFACE		STANDARD PACKING IN BOXES OF 10 PCS.						
	PLASTIC	W/O SPECIFICATION	GREY		WHITE					
23797	9	9	00	-	1	45	16	8,5	4,0	0,20
23798	9	9	-	00	1	45	16	6,1	4,0	0,20
23799	9	9	-	00	1	45	16	10,7	4,0	0,40
23801	9	9	00	-	1	45	16	5	4,0	0,20
23802	9	9	00	-	1	45	16	9	4,0	0,40
23803	9	0	00	-	1	45	16	9	4,0	0,40

23797 + 23803: TO BE USED IN TOP FRAME
23798-99 + 23801-02: TO BE USED IN BOTTOM FRAME



FITTING INSTRUCTIONS

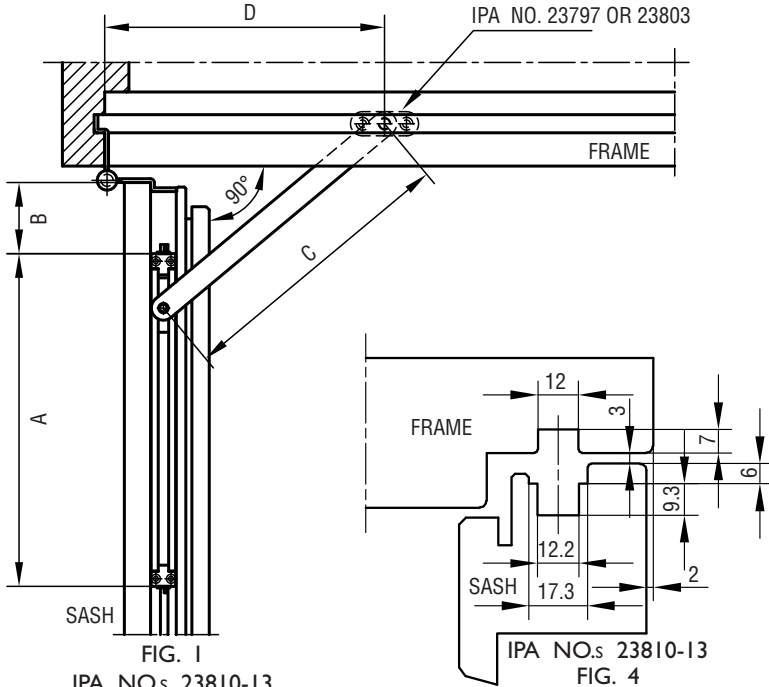

FIG. 1
IPA NO.s 23810-13
FOR THE TOP

FITTING INSTRUCTIONS:

1. ALUMINIUM RAIL WITH ARM IS MOUNTED IN THE TOP OF THE SASH (23810-13) OR AT THE BOTTOM OF THE SASH (23815-18). USE 4 PCS SCREW NO. 3.
2. THE PLASTIC FRAME FIXTURE IS MOUNTED IN THE TOP OF THE FRAME (23797 OR 23803) OR AT THE BOTTOM OF THE FRAME (23798-99 OR 23801-02). USE 2 PCS. SCREW NO. 4.
3. THE ARM IS PRESSED IN PLACE IN THE FRAME FIXTURE.

IPA NO.	SASH WIDTH MM	A MM	B MM	C MM	D MM
23810	330 - 480	250	15	110	102
23811	481 - 690	330	90	200	152
23812	691 - 900	435	195	330	230
23813	901 - 1100	465	305	450	280
23815	330 - 480	250	15	110	102
23816	481 - 690	330	90	200	152
23817	691 - 900	435	195	330	230
23818	901 - 1100	465	305	450	280

FIG. 3

WHEN THE OPENING ANGEL IS MORE THAN 90° A MECHANICAL RESTRICTOR WHICH PREVENTS THE DOOR FROM OPENING MORE THAN 90° MUST BE FITTED.

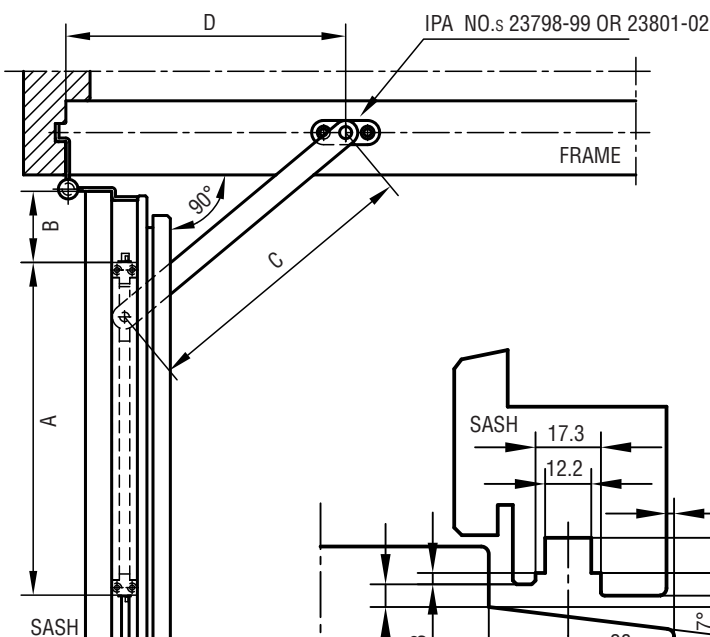

FIG. 2
IPA NO.s 23815-18
FOR THE BOTTOM

MAINTENANCE:

THE FITTINGS ARE NOT TO BE PAINTED. TEST THE OPERATION FROM TIME TO TIME. WHEN MOUNTING - LUBRICATE THE PIVOT/MOVABLE METAL PARTS OF THE MECHANISM WHILE ACTIVATING REPEATEDLY. HEREAFTER LUBRICATE MINIMUM TWICE A YEAR. DO NOT LUBRICATE THE ALUMINIUM RAILS. SEE ALSO SECTION H.

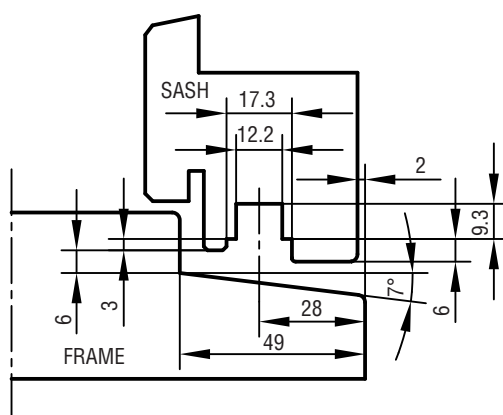

FIG. 5

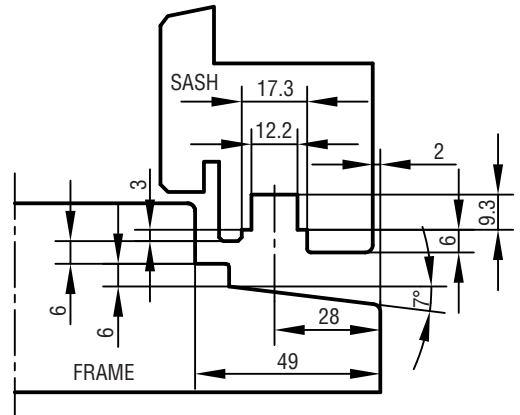
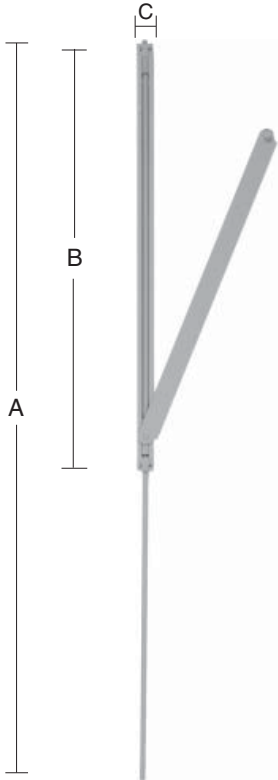

FIG. 6



FRICITION STAYS FOR DOORS IPA NO.s 23820-23



23820-21
LEFT

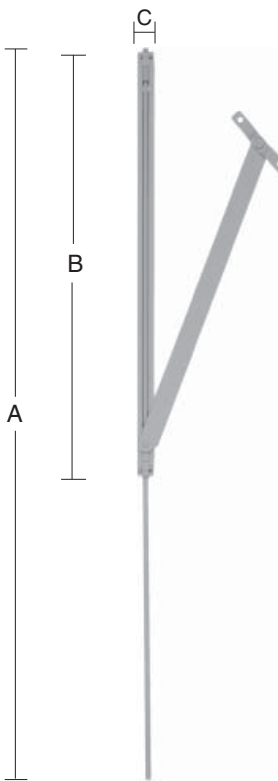

23822-23
LEFT

ORDERING NO.											
IPA NO.	MATERIAL			SURFACE	STANDARD PACKING IN BOXES OF 10 PIECES	A MM	B MM	SASH WIDTH MM	C MM	SCREW	APPROX. WEIGHT KG / EACH
	STEEL	LEFT	RIGHT	ELECTROPLATED							
23820	1	7	8	21	1	750	435	691-900	16	3,0	0,34
23821	1	7	8	21	1	1025	465	901-1100	16	3,0	0,43
23822	1	7	8	21	1	750	435	691-900	16	3,0	0,35
23823	1	7	8	21	1	1025	465	901-1100	16	3,0	0,44

FRAME FIXTURES IPA NO.s 23797 AND 23801-02, SEE PAGE F-01



FITTING INSTRUCTIONS

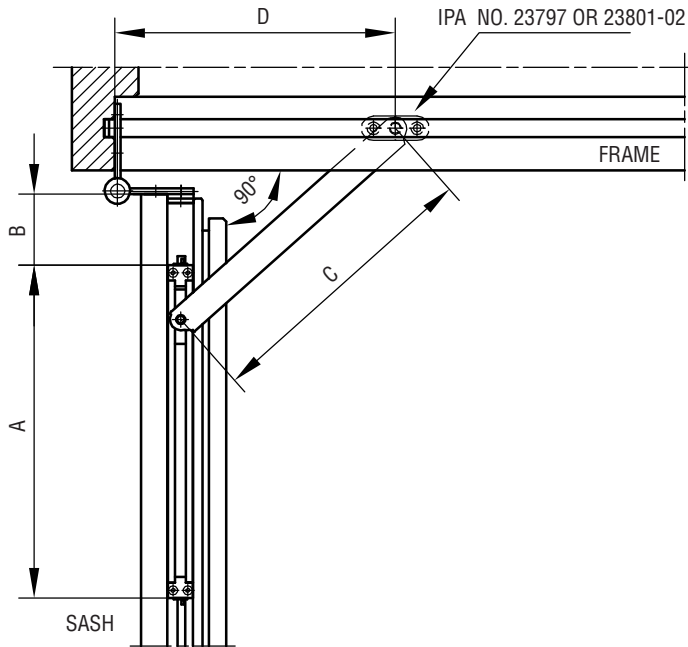

FIG. 1
IPA NO. 23820-21
LEFT

THE FRICTION STAY FOR DOORS
COMES AS LEFT AND RIGHT
USE LEFT FOR A LEFTHUNG DOOR.

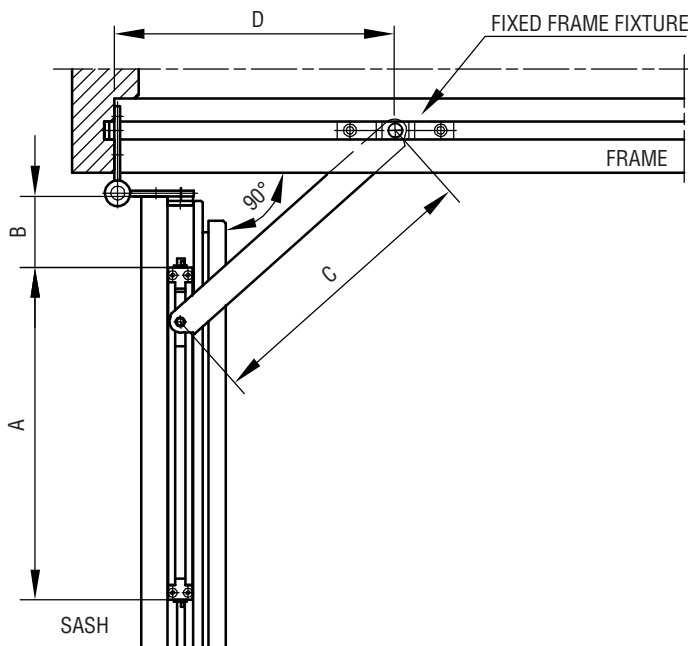

FIG. 2
IPA NO. 23822-23
LEFT

THE FRICTION STAY FOR DOORS
COMES AS LEFT AND RIGHT
USE LEFT FOR A LEFTHUNG DOOR.

IPA NO.	SASH WIDTH MM	A MM	B MM	C MM	D MM
23820	691 - 900	435	195	330	230
23821	901 - 1100	465	305	450	280
23822	691 - 900	435	195	330	230
23823	901 - 1100	465	305	450	280

FIG. 3

MONTERINGSVEJLEDNING:

1. ALUMINIUM RAIL WITH ARM IS MOUNTED IN THE TOP OF THE SASH. USE 4 PCS SCREW NO. 3.
2. 21820-21: THE PLASTIC FRAME FIXTURE IS MOUNTED IN THE TOP OF THE FRAME. USE 2 PCS. SCREW NO. 4. - SEE FIG. 1.
21822-23: THE FIXED FRAME FIXTURE IS MOUNTED IN THE TOP OF THE FRAME. USE 2 PCS. SCREW NO. 4. - SEE FIG. 2.
3. 21820-21: THE ARM IS PRESSED IN PLACE IN THE FRAME FIXTURE.

WHEN THE OPENING ANGEL IS MORE THAN 90° A MECHANICAL RESTRICTOR WHICH PREVENTS THE DOOR FROM OPENING MORE THAN 90° MUST BE FITTED.

EXAMPLE WOOD PROFILE

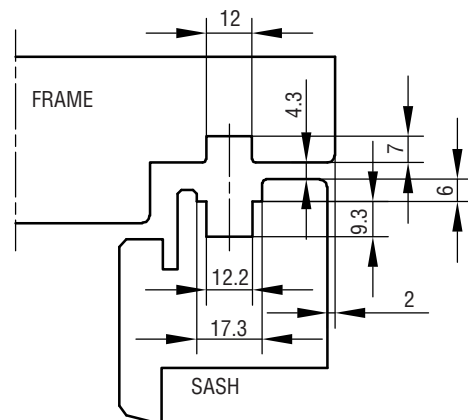

FIG. 4

MAINTENANCE:

THE FITTINGS ARE NOT TO BE PAINTED. TEST THE OPERATION FROM TIME TO TIME. WHEN MOUNTING - LUBRICATE THE PIVOT/ MOVABLE METAL PARTS OF THE MECHANISM WHILE ACTIVATING REPEATEDLY. HEREAFTER LUBRICATE MINIMUM TWICE A YEAR. DO NOT LUBRICATE THE ALUMINIUM RAILS. SEE ALSO SECTION H.



CONNECTION PIECES

IPA NO.s 23782-90

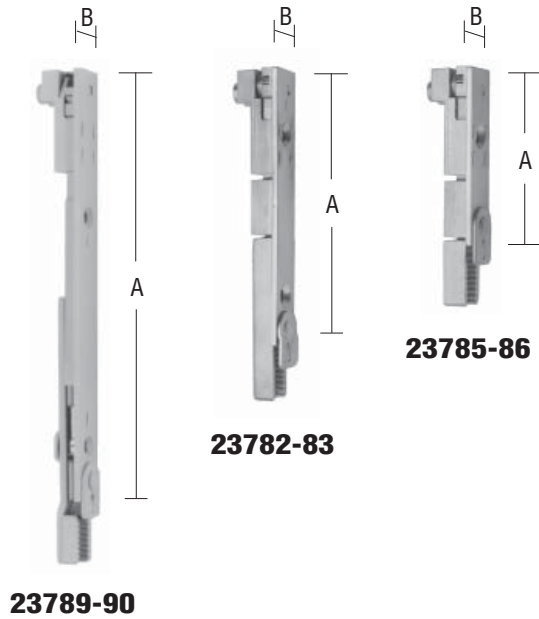

ORDERING NO.					A MM	B MM	SCREW	APPROX.WEIGHT KG / EACH
IPA NO.	MATERIAL	SURFACE		STANDARD PACKING IN BOXES OF 10 PIECES				
	STEEL/ALLOY	WITHOUT SPECIFICATION	ELECTROPLATED					
23785	0	0	21	1	63	16	4,0	0,07
23786	0	0	21	1	63	16	4,0	0,07
23782	0	0	21	1	100	16	4,0	0,09
23783	0	0	21	1	100	16	4,0	0,09
23789	0	0	21	1	160	16	4,0	0,11
23790	0	0	21	1	160	16	4,0	0,11

23783, 23786 AND 23789: TO BE USED AT THE BOTTOM
 23782, 23785 AND 23790: TO BE USED AT THE TOP



FITTING INSTRUCTIONS

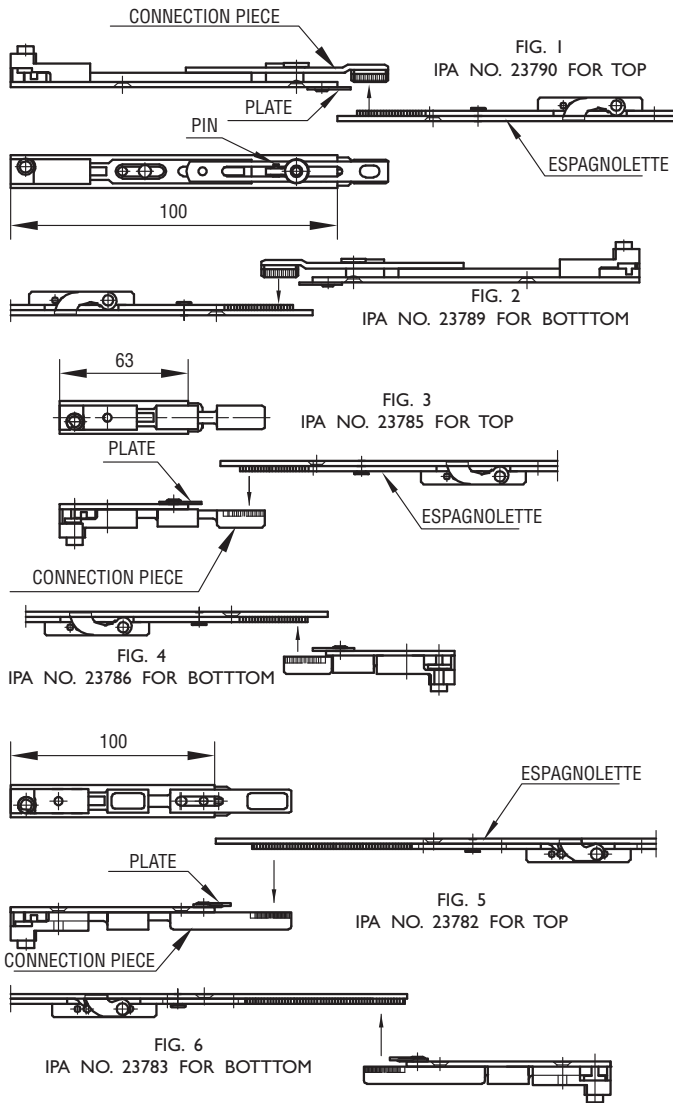

FITTING INSTRUCTIONS:

1. THE CONNECTION PIECE IS PLACED IN THE BOTTOM (23783/86/89) OF THE SIDE SASH OR IN THE TOP (23782/85/90) OF THE SIDE SASH, SO THAT THE UPPER/LOWER EDGE IS IN LEVEL WITH THE LOWER/UPPER EDGE OF THE SASH. USE SCREW 4.0 x 50.
IPA NO. 23782/85: WHEN MOUNTED AT THE TOP THE CONNECTION PIECE HAS TO BE FULLY EXTRACTED.
IPA NO. 23783/86: WHEN MOUNTED AT THE BOTTOM THE CONNECTION PIECE HAS TO BE FULLY COMPRESSED.
2. THE PLATE IS TURNED FOR MOUNTING OF ESPAGNOLETTE.
3. THE EXPAGNOLETTE (FOR EXAMPLE IPA NO. 23702) IS SET IN OPEN POSITION (SIDE BOLTS IN) THE TOOTHED PART OF THE ESPAGNOLETTE IS CONNECTED WITH THE CONNECTION PIECE, SO THAT THE FACE PLATE OF THE ESPAGNOLETTE FITS TIGHTLY AGAINST THE FACE PLATE OF THE CONNECTION PIECE.
4. PLATE ON CONNECTION PIECE IS TURNED BACK.
5. FRICTION STAY IS MOUNTED, IPA NO.s 23791-96.
6. WHEN THE ESPAGNOLETTE IS ACTIVATED THE MOUNTING SECURITY PIN BRAKES OFF (IPA NO: 23810-21) AND THE SYSTEM IS NOW FULLY OPERATIONAL.

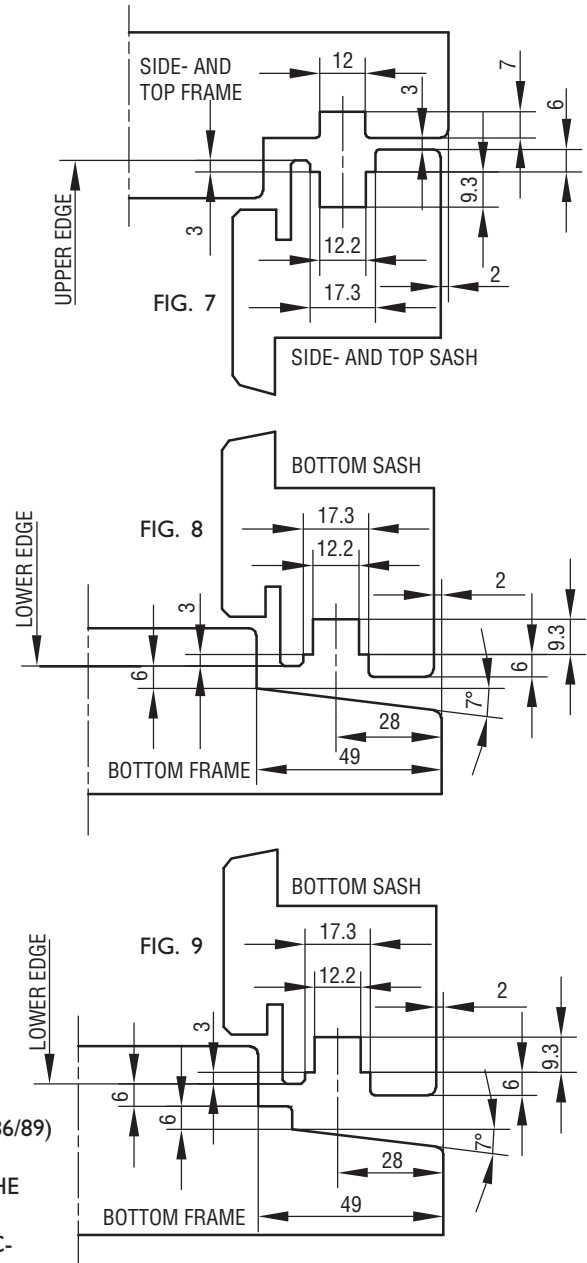

PLEASE NOTE! WHEN MOUNTING THE CONNECTION PIECE IN THE ESPAGNOLETTE HAS TO BE OPENED (SIDE BOLTS IN) BEFORE SHORTENING.

MAINTENANCE:

THE FITTINGS ARE NOT TO BE PAINTED. TEST THE OPERATION FROM TIME TO TIME. WHEN MOUNTING - LUBRICATE THE PIVOT/ MOVABLE METAL PARTS OF THE MECHANISM WHILE ACTIVATING REPEATEDLY. HEREAFTER LUBRICATE MINIMUM TWICE A YEAR. DO NOT GREASE THE ALUMINIUM RAILS. SEE ALSO SECTION H.



ACCESSORIES FOR SIDE BOLT ESPAGNOLETTES

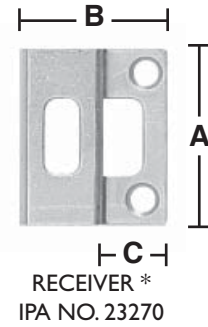
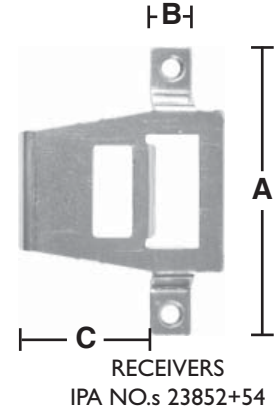
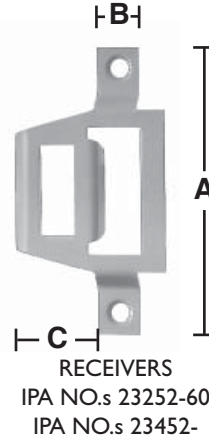
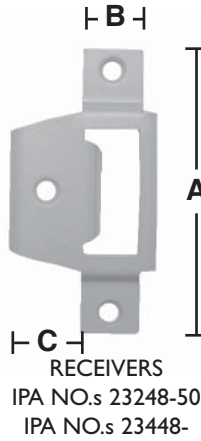

ORDERING NO.														
IPA NO.	MATERIAL		WITHOUT SPECIFICATION	SURFACE		STANDARD PACKING IN BOXES OF 20 PIECES	STANDARD PACKING IN BOXES OF 25 PIECES	INDUSTRY PACKING IN BOXES OF 100 PIECES	A MM	B MM	C MM	MATERIAL MM	SCREW	APPROX. WEIGHT KG/100 PCS.
	STEEL	STAINLESS STEEL		ELECTROPLATED	UNMACHINED									
23248	1	-	0	21	-	-	1	-	79,5	17	21	1,50	3,5	2,6
23249	1	-	0	21	-	-	1	-	78,5	12	23	1,50	3,5	2,0
23250	1	-	0	21	-	-	1	-	78,5	12	24	1,50	3,5	2,0
23252	1	-	0	21	-	-	1	-	78,5	12	24	1,50	3,5	2,0
23259	1	-	0	21	-	-	1	-	50	47	-	1,50	3,5	2,0
23260	1	-	0	21	-	-	1	-	82	17	21	1,50	3,5	2,0
23269	1	-	0	21	-	1	-	2	46	25	-	7,00	4,0	3,0
23270	-	8	0	-	86	1	-	-	46	38,5	18	1,75	4,0	2,6
23448	1	-	0	21	-	-	1	-	79,5	17	21	1,50	3,5	2,0
23450	1	-	0	21	-	-	1	-	78,5	12	24	1,50	3,5	2,0
23452	1	-	0	21	-	-	1	-	78,5	12	24	1,50	3,5	2,0
23460	1	-	0	21	-	-	1	-	79,5	17	21	1,50	3,5	2,0
23852	1	-	0	21	-	-	1	-	80,5	12	37	1,50	3,5	2,2
23853	1	-	0	21	-	-	1	-	80,5	12	38	1,50	3,5	2,3
23854	1	-	0	21	-	-	1	-	80,5	12	38	1,50	3,5	2,2

* THESE RECEIVERS HAVE BEEN DESIGNED SPECIALLY FOR THE ESPAGNOLETTE PROGRAMME IPA NO. 23701-69/23841-48 AND THE RECEIVERS IPA NO. 23269 OR 23270 HAS TO BE USED WHEN THE ESPAGNOLETTE IS MOUNTED IN THE BOTTOM SASH.



ACCESSORIES FOR ROLLER BOLT ESPAGNOLETTES

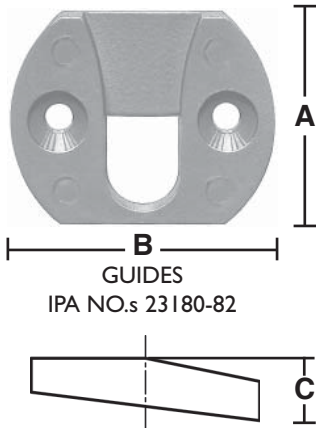

GUIDES
IPA NO.s 23180-82

ORDERING NO.											
IPA NO.	MATERIAL	SURFACE			STANDARD PACKING IN BOXES OF 10 PIECES	STANDARD PACKING IN BOXES OF 100 PIECES	A MM	B MM	C MM	SCREW	APPROX. WEIGHT KG/EACH
	PLASTIC	WITHOUT SPECIFICATION	WHITE								
23180	9	0	56	1	2	38	30	8	4,0	0,005	
23181	9	0	56	1	2	38	30	11	4,0	0,006	
23182	9	0	56	1	-	38	30	13	4,0	0,008	

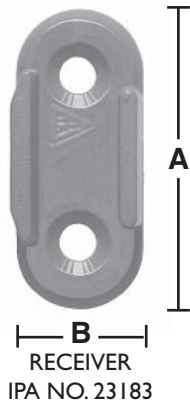

RECEIVER
IPA NO. 23183

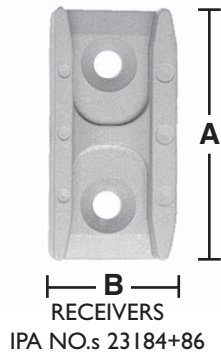

RECEIVERS
IPA NO.s 23184+86

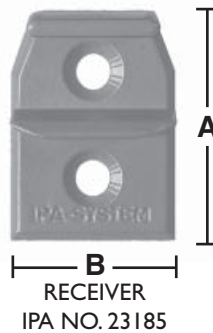

RECEIVER
IPA NO. 23185

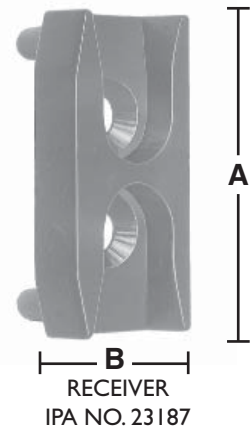

RECEIVER
IPA NO. 23187

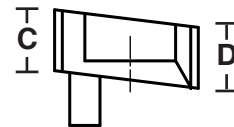
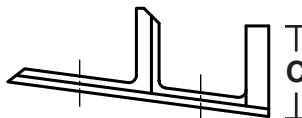
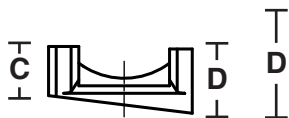
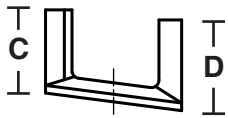

ORDERING NO.											
IPA NO.	MATERIAL	SURFACE			STANDARD PACKING IN BOXES OF 20 PIECES	A MM	B MM	C MM	D MM	SCREW	APPROX. WEIGHT KG/EACH
	STEEL	WITHOUT SPECIFICATION	ELECTROPLATED								
23183	1	0	21	1	43	18	11	12	4,0	0,016	
23184	1	0	21	1	39	19	6,5	8,5	4,0	0,022	
23185	1	0	21	1	25	35	10	12	4,0	0,015	
23186	1	0	21	1	39	19	8,5	10,5	4,0	0,022	
23187	1	0	21	1	39	20	8	8	4,0	0,022	



ACCESSORIES FOR MUSHROOM HEAD BOLT ESPAGNOLETTES

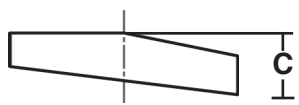
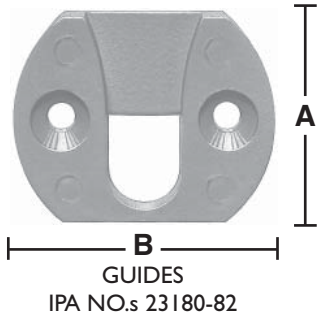

		ORDERING NO.								
IPA NO.	MATERIAL	WITHOUT SPECIFICATION	SURFACE	STANDARD PACKING IN BOXES OF 10 PIECES	STANDARD PACKING IN BOXES OF 100 PIECES	A MM	B MM	C MM	SCREW	APPROX. WEIGHT KG/EACH
	PLASTIC		WHITE							
23180	9	0	56	1	2	38	30	8	4,0	0,005
23181	9	0	56	1	2	38	30	11	4,0	0,006
23182	9	0	56	1	-	38	30	13	4,0	0,008

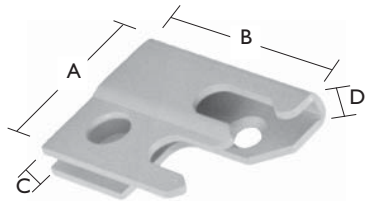

RECEIVER IPA NO. 23190

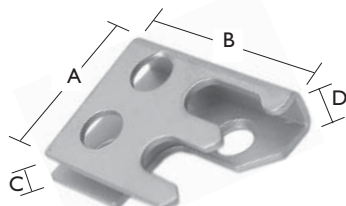

RECEIVER IPA NO. 23191

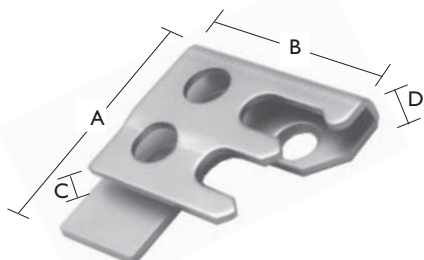
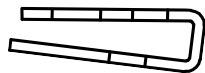

RECEIVER NO. 23192



		ORDERING NO.									
IPA NO.	MATERIAL	WITHOUT SPECIFICATION	SURFACE	STANDARD PACKING IN BOXES OF 25 PIECES	INDUSTRY PACKING IN BOXES OF 100 PIECES	A MM	B MM	C MM	D MM	SCREW	APPROX. WEIGHT KG/100 PCS.
	STAINLESS STEEL		UNMACHINED								
23190	8	0	86	1	2	32,5	40	7	8	4,0	0,024
23191	8	0	86	-	2	31	40	7	10	4,0	0,024
23192	8	0	86	1	2	44	40	7	8	4,0	0,026



ACCESSORIES FOR ESPAGNOLETTES



GUIDE PLATE
IPA NO. 23220



GUIDE PLATE
IPA NO. 23221

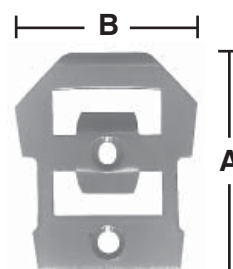

RECEIVER
IPA NO. 23222



GUIDE PLATE
IPA NO. 23521

ORDERING NO.											
IPA NR.	MATERIAL	WITHOUT SPECIFICATION	SURFACE		STANDARD PACKING IN BOXES OF 20 PIECES	STANDARD PACKING IN BOXES OF 50 PIECES	A MM	B MM	MATERIAL MM	SCREW	APPROX. WEIGHT KG/EACH
	STEEL		ELECTROPLATED	GALVANIZED							
23220	1	0	21	-	-	1	85	17	3	4,0	0,03
23221	1	0	21	-	-	1	85	17	3	4,0	0,03
23222	1	0	21	87	-	1	47	40	2	3,5	0,03
23521	1	0	21	-	1	-	35	17	1,5	3,0	0,01



EXTENSION PIECES

IPA NO.s 23580-96

**WITH
SIDE BOLTS
TOP**

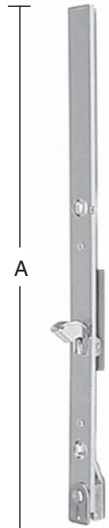

**WITHOUT
SIDE BOLTS**

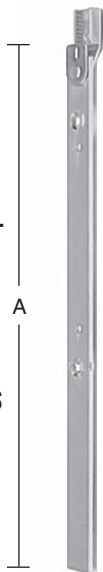

**23580+
83+86+89+
92+95+97**

**WITH
SIDE BOLTS
BOTTOM**

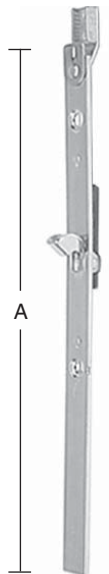

**23582+
85+88**

**23581+
84+87+90+
93+96**

ORDERING NO.												
IPA NO.	MATERIAL	SURFACE			A MM	SIDE BOLTS MM	FACEPLATE MM	THICKNESS PLATE MM	SCREW	POSITIONING	CAN BE SHORTENED W/ FRICTION STAY MM	CAN BE SHORTENED W/O FRICTION STAY MM
	STEEL	SQUARE EDGES	ELECTROPLATED	STANDARD PACKING IN BOXES OF 10 PIECES								
23580	1	6	21	1	250	12	16/17	2,5	4,0	TOP	50	70
23581	1	6	21	1	250	12	16/17	2,5	4,0	BOTTOM	50	70
23582	1	6	21	1	250	-	16/17	2,5	4,0	TOP/BOTTOM	50	70
23583	1	6	21	1	380	12	16/17	2,5	4,0	TOP	50	70
23584	1	6	21	1	380	12	16/17	2,5	4,0	BOTTOM	50	70
23585	1	6	21	1	380	-	16/17	2,5	4,0	TOP/BOTTOM	50	70
23586	1	6	21	1	500	12	16/17	2,5	4,0	TOP	50	70
23587	1	6	21	1	500	12	16/17	2,5	4,0	BOTTOM	50	70
23588	1	6	21	1	500	-	16/17	2,5	4,0	TOP/BOTTOM	50	70
23589	1	6	21	1	250	15	16/17	2,5	4,0	TOP	50	70
23590	1	6	21	1	250	15	16/17	2,5	4,0	BOTTOM	50	70
23592	1	6	21	1	380	15	16/17	2,5	4,0	TOP	50	70
23593	1	6	21	1	380	15	16/17	2,5	4,0	BOTTOM	50	70
23595	1	6	21	1	500	15	16/17	2,5	4,0	TOP	50	70
23596	1	6	21	1	500	15	16/17	2,5	4,0	BOTTOM	50	70
23597	1	6	21	1	1000	15	16/17	2,5	4,0	TOP	50	70



FITTING INSTRUCTIONS

IPA NO.	A MM	B MM	C MM	POSITION
23580	250	12	85	TOP
23581	250	12	95	BOTTOM
23582	250	-	-	TOP/BOTTOM
23583	380	12	215	TOP
23584	380	12	225	BOTTOM
23585	380	-	-	TOP/BOTTOM
23586	500	12	335	TOP
23587	500	12	345	BOTTOM
23588	500	-	-	TOP/BOTTOM
23589	250	15	85	TOP
23590	250	15	95	BOTTOM
23592	380	15	215	TOP
23593	380	15	225	BOTTOM
23595	500	15	335	TOP
23596	500	15	345	BOTTOM
23597	1000	15	840	TOP

FIG. 1

FACEPLATE: 16/17 MM

SHORTENING POSSIBILITIES:

WITHOUT FRICTION STAY:

70 MM AT TOP/BOTTOM WITH SIDE BOLTS OUT/IN.

WITH FRICTION STAY:

50 MM AT TOP/BOTTOM WITH SIDE BOLTS OUT/IN.

USE SCREW NO. 4,0.

EXAMPLE WOODPROFILE

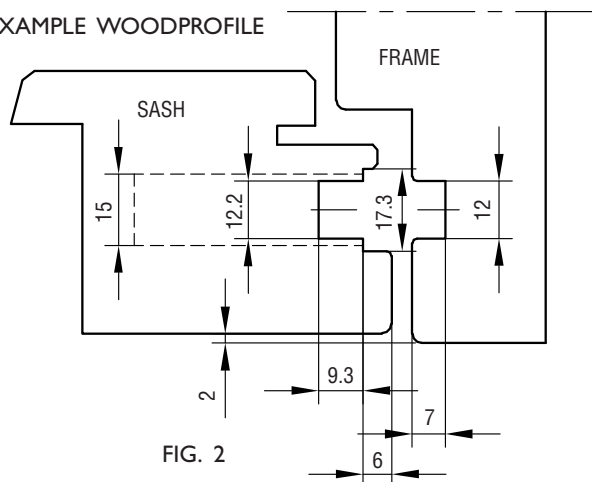

FIG. 2

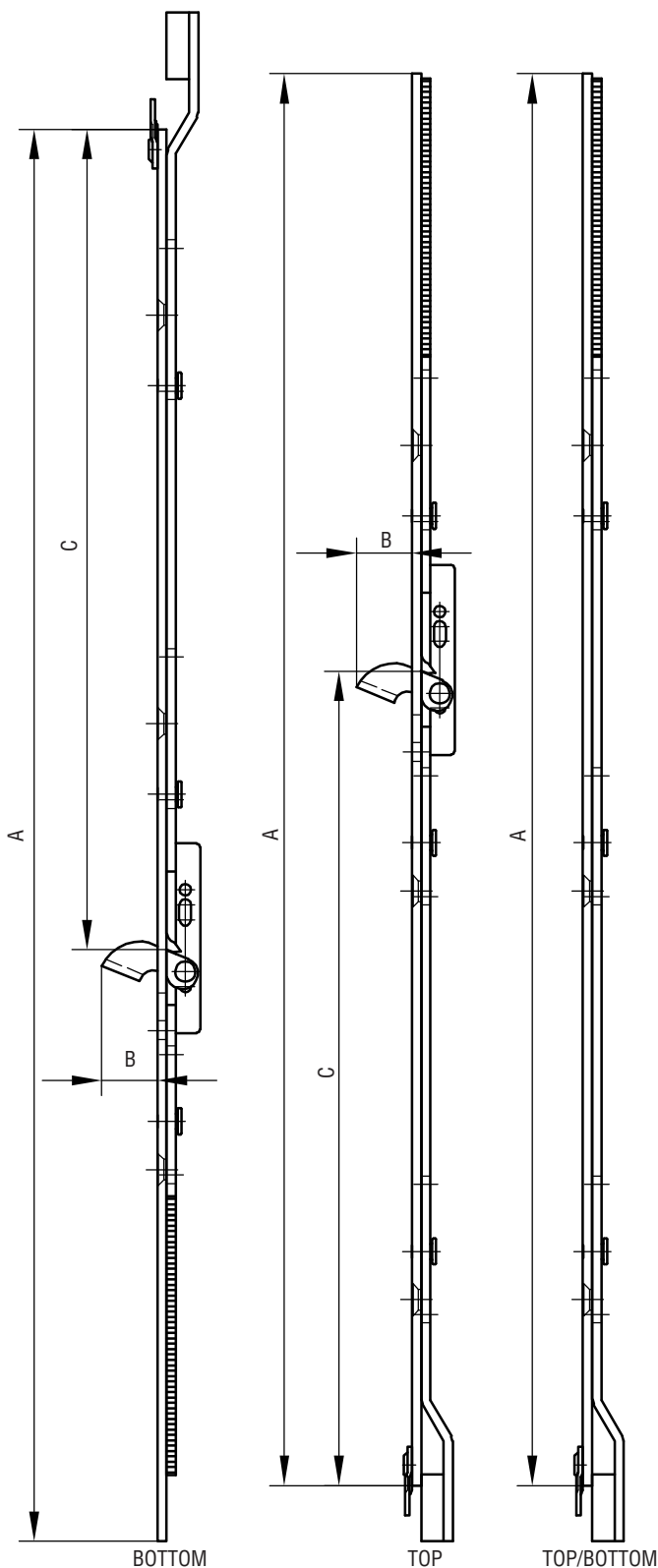

FIG. 3

MAINTENANCE: THE FITTINGS ARE NOT TO BE PAINTED. TEST THE OPERATION FROM TIME TO TIME. WHEN MOUNTING - LUBRICATE THE PIVOT/MOVABLE METAL PARTS OF THE MECHANISM WHILE ACTIVATING REPEATEDLY. HEREAFTER LUBRICATE MINIMUM TWICE A YEAR. SEE ALSO SECTION H.



SHOOTBOLTS EXTENSIONS

IPA NO. 23780

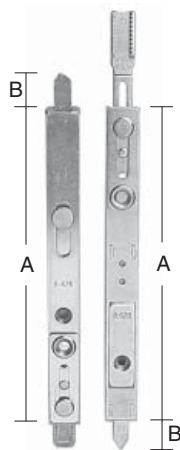

23780
1 SET

ORDERING NO.					A MM	B MM	FACEPLATE MM	SCREW
IPA NO.	STEEL/ALLOY	WITHOUT SPECIFICATION	ELECTROPLATED	STANDARD PACKING IN BOXES OF 5 SETS				
23780	0	0	21	1	160	16	16	4,0

FOR MOUNTING IN TOP/BOTTOM OR IN RIGHT/LEFT SIDES



HANDLES FOR WINDOW ESPAGNOLETTES



23228-29+33-34

RIGHT

HANDLES

ORDERING NO.											
IPA NO.	MATERIAL		SURFACE		STANDARDPACKING IN BOXES OF 10 PCS.	PIN MM	DISTANCE BETWEEN SCREWHOLE MM	LENGTH OF PIN MM	HOLES FOR SCREWS MM	WEIGHT APPROX. KGS / EACH.	
	ALLOY	LEFT	RIGHT	DULL CROME							CROME
23228	0	7	8	80	-	1	8	42	43	5	0,15
23229	0	7	8	-	81	1	8	42	43	5	0,15
23233	0	7	8	80	-	1	7	42	43	5	0,15
23234	0	7	8	-	81	1	7	42	43	5	0,15



23238

SAFETY LOCK

ORDERING NO.						
IPA NO.	MATERIAL		SURFACE		STANDARDPACKING IN BOXES OF 5 PCS.	HOLE MM
	STEEL	W/O SPECIFICATION	DULL CROME	CROME		
23238	1	0	80	81	1	8 X 8

FOR HANDLES 23228-29+33-34



ADJUSTABLE FRICTION STAY

IPA NO. 21327

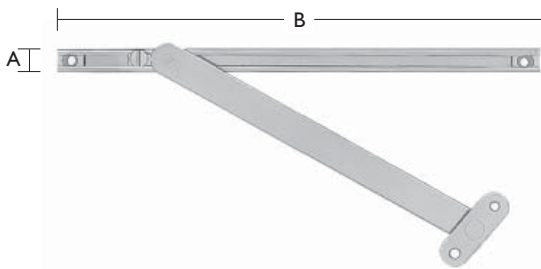
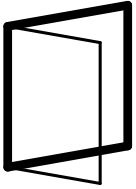

ORDERING NO.									
IPA NO.	MATERIAL	SURFACE		STANDARD PACKING IN BOXES OF 25 PCS.	A MM	B MM	MATERIAL MM	SCREW	APPROX. WEIGHT KG / PCS.
	STEEL	WITHOUT SPECIFICATION	ELECTROPLATED						
21327	1	0	21	1	12	260	17 x 3	4,0	0,14

- CONCEALED FITTING
- OPENS UP TILL 100°
- FRICTION IN ALL POSITIONS
- ADJUSTABLE FRICTION
- ANODIZED ALUMINIUM RAIL



FITTING INSTRUCTIONS

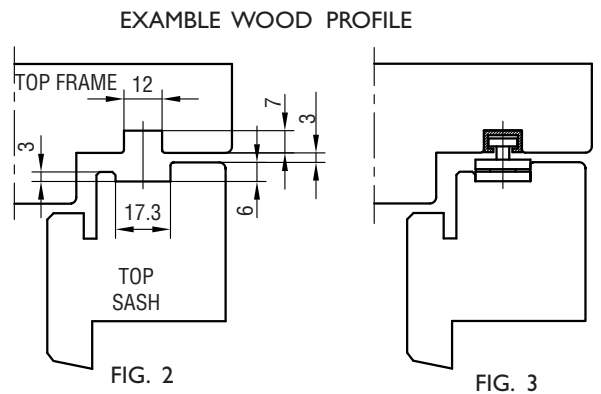
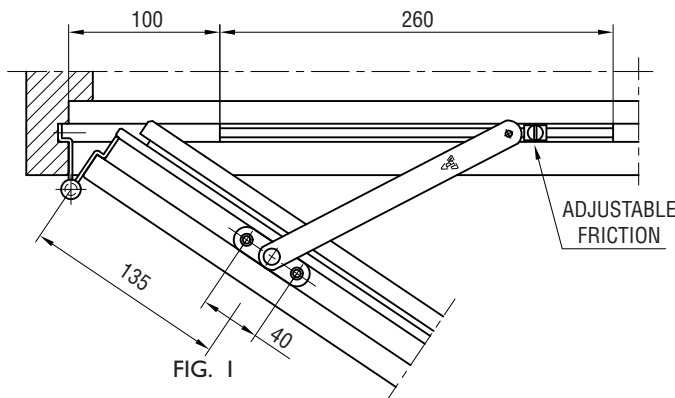

MAINTENANCE:

THE FITTINGS ARE NOT TO BE PAINTED. TEST THE OPERATION FROM TIME TO TIME. WHEN MOUNTING - LUBRICATE THE PIVOT/MOVABLE METAL PARTS OF THE MECHANISM WHILE ACTIVATING REPEATEDLY. HEREAFTER LUBRICATE MINIMUM TWICE A YEAR. DO NOT LUBRICATE THE ALUMINIUM RAILS. SEE ALSO SECTION H.



ADJUSTABLE FRICTION STAY

IPA NO. 22411

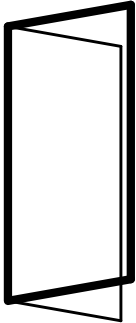

ORDERING NO.					A MM	B MM	MATERIAL MM	SCREW	APPROX. WEIGHT KG / PCS.
IPA NO.	MATERIAL	SURFACE		STANDARD PACKING IN BOXES OF 25 PCS.					
	22411	1	0		21	1	12	400	17 X 3

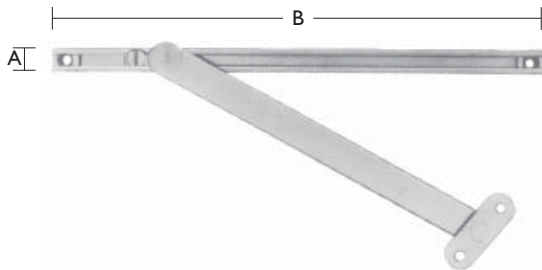

- CONCEALED FITTING
- OPENS UP TILL 100°
- FRICTION IN ALL POSITIONS
- ADJUSTABLE FRICTION
- ANODIZED ALUMINIUM RAIL



FITTING INSTRUCTIONS

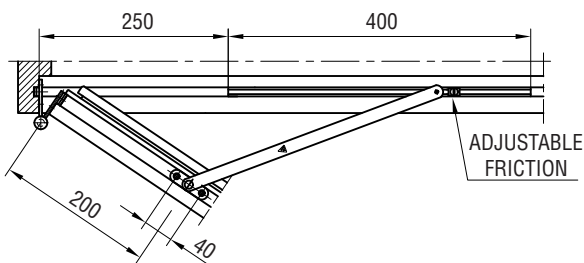

FIG. 1

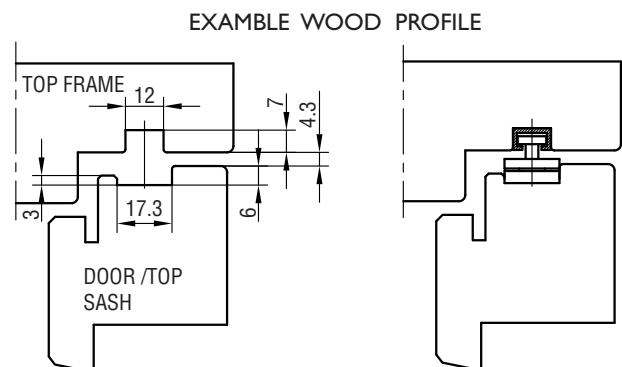

FIG. 2

FIG. 3

MAINTENANCE:

THE FITTINGS ARE NOT TO BE PAINTED. TEST THE OPERATION FROM TIME TO TIME. WHEN MOUNTING - LUBRICATE THE PIVOT/MOVABLE METAL PARTS OF THE MECHANISM WHILE ACTIVATING REPEATEDLY. HEREAFTER LUBRICATE MINIMUM TWICE A YEAR. DO NOT LUBRICATE THE ALUMINIUM RAILS. SEE ALSO SECTION H.



ACCESSORIES FOR IPA SYSTEM FITTINGS



COUPLING HINGES
IPA NO.s 13241-43



SUPPORT FITTING
IPA NO. 21221



SUPPORT FITTING
IPA NO. 21222



RECEIVER FOR 21221
IPA NO. 21223



SUPPORT FITTING
IPA NO. 21225



GUIDE BLOCKS FOR SASHES/DOORS
IPA NO. 23230-31



CLOSING CATCH
IPA NO. 21458



CLOSING CATCH
IPA NO. 21460



CENTER HINGE
IPA NO. 21541

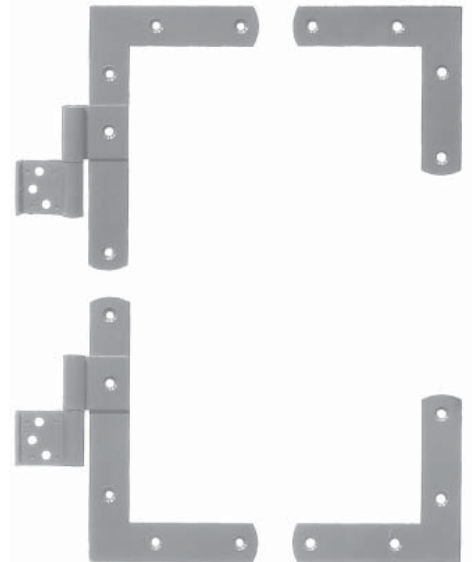

HINGED ANGLE BRACKETS
IPA NO.s 21552+62

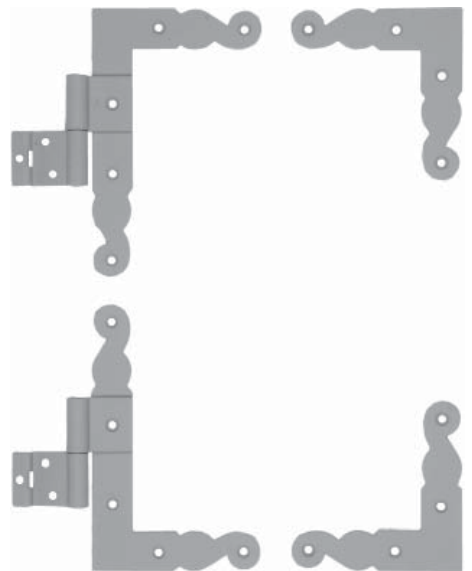

HINGED ANGLE BRACKETS
IPA NO.s 21554+64

IPA NO.	ORDERING NO.																
	MATERIAL					SURFACE					STANDARD PACKING IN BOXES OF 5 SETS	STANDARD PACKING IN BOXES OF 20 PIECES	STANDARD PACKING IN BOXES OF 25 PIECES	INDUSTRY PACKING IN BOXES OF 100 PIECES			
	ALUMINIUM	STEEL	STEEL W/BRASS PIN	STEEL W/LOOSE STEEL PIN	PLASTIC	WITHOUT SPECIFICATION	SQUARE EDGES	LEFT	RIGHT	ANODIZED					ELECTROPLATED	ELECTROPLATED YELLOW	WHITE
13241	-	-	3	5	-	6	-	-	-	-	25	-	-	-	1	-	-
13243	-	-	3	-	-	6	-	-	-	-	21	-	-	-	-	-	2
	-	-	3	-	-	6	-	-	-	-	25	-	-	-	1	-	-
21221	-	1	-	-	-	0	-	-	-	21	25	-	-	-	1	-	-
21222	0	-	-	-	-	0	-	-	00	-	-	-	-	-	1	-	-
21223	-	1	-	-	-	0	-	-	-	21	-	-	-	-	1	-	-
21225	0	-	-	-	-	0	-	-	00	-	-	-	-	-	1	-	-
21458	-	1	-	-	-	-	7	8	-	-	25	-	-	-	1	-	-
21460	-	1	-	-	-	0	-	-	-	-	25	-	-	-	1	-	-
21541	-	1	-	-	-	0	-	-	-	-	-	-	-	87	1	-	-
21552	-	1	-	-	-	-	7	8	-	-	-	-	-	87	1	-	-
21554	-	1	-	-	-	-	7	8	-	-	-	-	-	87	1	-	-
21562	-	1	-	-	-	-	7	8	-	-	-	-	-	87	1	-	-
21564	-	1	-	-	-	-	7	8	-	-	-	-	-	87	1	-	-
23230	-	-	-	-	9	0	-	-	-	-	-	-	-	56	-	1	-
23231	-	-	-	-	9	0	-	-	-	-	-	-	-	56	-	1	-



ACCESSORIES FOR IPA SYSTEM FITTINGS



FLUSH BOLT
IPA NO. 23301



FLUSH BOLT
IPA NO. 23303



FLUSH BOLT
IPA NO. 23305



FLUSH BOLT
IPA NO.S 23308-09



RECEIVER
IPA NO. 23340



WINDOW STAY
IPA NO. 21318

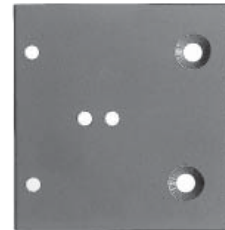

THREADED PLATE
FOR DOOR HINGE
IPA NO. 12721



THREADED PLATE
FOR REVERSIBLE
PROJECTING GEARS
IPA NO. 21155



BRACKETS FOR
SASHES
IPA NO. 23531



COVER STRIP
IPA NO. 23501

ORDERING NO.

IPA NO.	MATERIAL		WITHOUT SPECIFICATION	ROUND EDGES	SQUARE EDGES	LEFT	RIGHT	SURFACE				STANDARD PACKING IN BOXES OF 10 PIECES	STANDARD PACKING IN BOXES OF 20 PIECES	STANDARD PACKING IN BOXES OF 25 PIECES
	STEEL	PLASTIC						ELECTROPLATED	ELECTROPLATED YELLOW	WHITE	GALVANIZED			
12721	1	-	0	-	-	-	-	21	-	-	-	-	-	1
21155	1	-	0	-	-	-	-	21	-	-	-	-	-	1
21318	1	-	-	-	-	7	8	-	25	-	-	1	-	-
23301	1	-	0	-	6	-	-	21	-	-	-	1	-	-
23303	1	-	-	-	6	-	-	21	-	-	-	1	-	-
23305	1	-	-	5	-	-	-	21	-	-	-	1	-	-
23308	1	-	-	-	6	-	-	21	-	-	-	1	-	-
23309	1	-	-	-	6	-	-	21	-	-	-	1	-	-
23340	-	9	0	-	-	-	-	-	-	56	-	-	1	-
23501	1	-	0	-	-	-	-	-	-	-	87	1	-	-
23531	1	-	0	-	-	-	-	21	-	-	-	-	1	-



CASEMENT STAYS AND - HOOKS

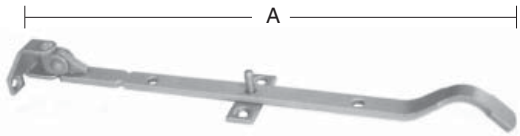

IPA NO. 21311-13

CASEMENT STAYS

ORDERING NO.										
IPA NO.	MATERIAL	SURFACE			STANDARD PACKING IN BOXES OF 10 PIECES	A MM	MATERIAL	SCREW	APPROX.WEIGHT KG/EACH	
	STEEL	WITHOUT SPECIFICATION	ELECTROPL/WHITE	ELECTROPLATED						ELECTROPLATED YELLOW
21311	1	0	06	21	25	1	220	15X4	4,0	0,17
21313	1	0	06	21	25	1	310	15X4	4,0	0,21

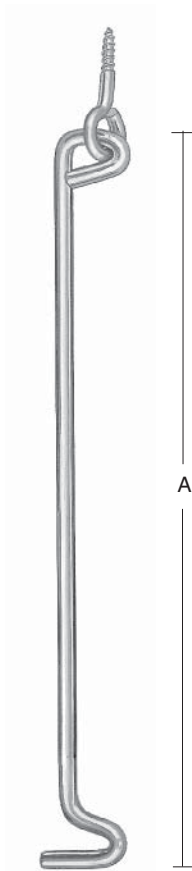

IPA NO.s 21343-57

CASEMENT HOOKS

ORDERING NO.										
IPA NO.	MATERIAL	SURFACE			STANDARD PACKING IN BOXES OF 25 PIECES	SINGLE PCS.	A MM	MATERIAL	APPROX.WEIGHT KG/100 PCS.	
	STEEL	WITHOUT SPECIFICATION	ELECTROPL/WHITE	ELECTROPLATED YELLOW						GALVANIZED
21343	1	0	06	25	87	1	-	105	6	5,0
21345	1	0	06	25	87	1	-	155	6	6,4
21347	1	0	06	25	87	1	-	210	6	7,5
21349	1	0	06	25	87	1	-	260	6	8,8
21351	1	0	06	25	87	1	-	310	6	10,0
21353	1	0	06	25	87	1	-	390	6	11,8
21355	1	0	06	-	87	1	-	470	6	13,5
21357	1	0	-	-	87	-	3	625	8	36,6



HOOK HOLDERS, HOOK CATCHES AND NAILS



A

B

IPA NO. 21359



A

B

IPA NO. 21360

HOOK HOLDERS

ORDERING NO.											
IPA NO.	MATERIAL		WITHOUT SPECIFICATION	SURFACE			STANDARD PACKING IN BOXES OF 100 PIECES	A MM	B MM	SCREW	APPROX WEIGHT KG/100 PCS.
	PLASTIC			GREY	WHITE						
21359	9	0	-	56	1		18,5	9,5	-	0,10	
21360	9	0	54	56	1		19,0	12,0	3,5	0,19	

HOOK CATCHES



A

IPA NO.s 21361-63

ORDERING NO.														
IPA NO.	MATERIAL		WITHOUT SPECIFICATION	SURFACE					STANDARD PACKING IN BOXES OF 25 PIECES	STANDARD PACKING IN BOXES OF 100 PIECES	A MM	HOLE MM	THICKNESS MM	APPROX WEIGHT KG/EACH
	STEEL			ELECTROPL./WHITE	BROWN	ELECTROPLATED	ELECTROPL. YELLOW	GALVANIZED						
21361	1	0	-	-	21	25	-	-	1	25	8	4,0	0,6	
21363	1	0	06	12	21	25	87	1	-	25	8	4,7	0,8	

NAILS



A

IPA NO. 21369

ORDERING NO.										
IPA NO.	MATERIAL		WITHOUT SPECIFICATION	SURFACE			STANDARD PACKING IN BOXES OF 1 KG.	A MM	THICKNESS MM	APPROX WEIGHT KG/100 PCS.
	STEEL			ELECTROPL./WHITE	ELECTROPLATED	ELECTROPL. YELLOW				
21369	1	0	06	21	25	1	25	2,5	0,1	

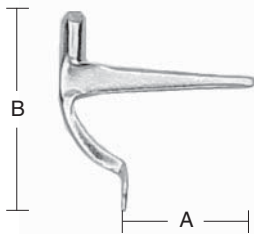

B

A

IPA NO. 21381



B

IPA NO. 21382

HOOK CATCHES

ORDERING NO.																	
IPA NO.	MATERIAL		WITHOUT SPECIFICATION	SURFACE					STANDARD PACKING IN BOXES OF 50 PIECES	STANDARD PACKING IN BOXES OF 100 PIECES	INDUSTRY PACKING IN BOXES OF 100 PIECES	INDUSTRY PACKING IN BOXES OF 250 PIECES	A MM	B MM	PIN MM	HOLE MM	APPROX WEIGHT KG/100 PCS.
	STEEL	BRASS		ELECTROPL./WHITE	ELECTROPLATED	ELECTROPL. YELLOW	POLISHED										
21381	1	-	0	06	21	25	-	-	1	-	2		28	47	5,5	3,5	0,75
	-	6	0	-	-	-	85	1	-	2	-						
21382	1	-	0	06	-	-	-	-	-	-	2		13,3	34	5,6	3,5	1,4
	1	-	0	-	21	25	-	1	-	-	2						



CASEMENT HOOKS



IPA NO. 21376



IPA NO. 21371



IPA NO.s 21370 & 21372-73



IPA NO. 21378



IPA NO. 21379

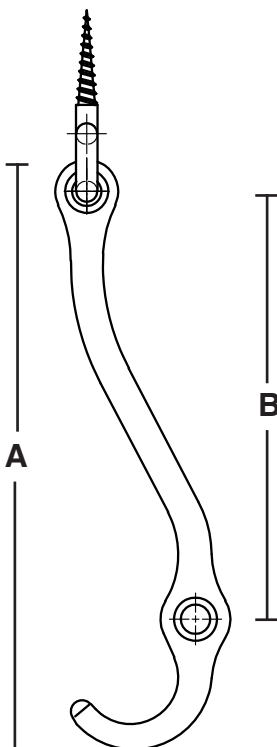
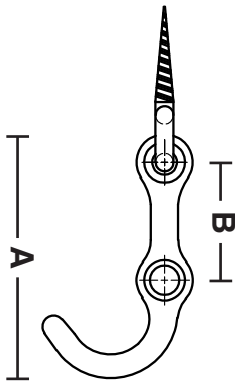

CASEMENT HOOK AND HOOK CATCH

ORDERING NO.																
IPA NO.	MATERIAL			SURFACE								A MM	B MM	HOLE FOR PIN MM	APPROX. WEIGHT KG/100 PCS.	
	ZINK ALLOY	STEEL	BRASS	WITHOUT SPECIFICATION	ELECTROPLATED/WHITE	ELECTROPLATED	ELECTROPLATED YELLOW	POLISHED	STANDARD PACKING IN BOXES OF 50 PIECES	STANDARD PACKING IN BOXES OF 100 PIECES	INDUSTRY PACKING IN BOXES OF 100 PIECES					INDUSTRY PACKING IN BOXES OF 250 PIECES
21370	0	-	-	0	06	21	25	-	-	-	-	2	130	95	6	5,0
21371	0	-	-	0	06	21	25	-	-	-	-	2	130	95	6	6,0
21372	-	1	-	0	06	21	25	-	1	-	-	-	130	95	6	5,0
	-	1	-	0	-	21	25	-	-	-	-	2				
21373	-	1	-	0	06	21	25	-	1	-	-	2	170	140	6	6,0
	-	1	-	0	06	21	25	-	-	1	-	-				
21376	-	1	-	0	06	21	25	-	-	1	-	-	54	27	6	1,3
	-	1	-	0	-	21	-	-	-	-	-	2				
21378	0	-	-	0	-	-	25	-	1	-	-	-	120	93	6	4,8
	0	-	-	0	06	21	25	-	-	-	-	2				
21379	0	-	-	0	-	21	25	-	1	-	-	-	120	93	6	5,6
	0	-	-	0	06	21	25	-	-	-	-	2				



FITTING INSTRUCTIONS

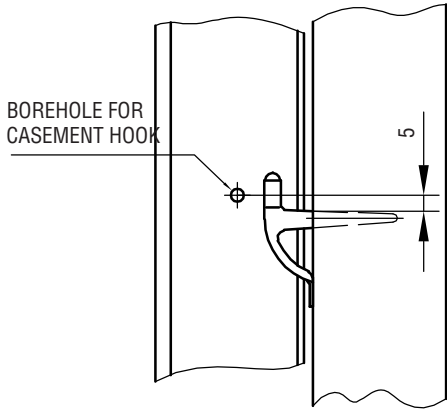

FIG. 1
IPA NO. 21381

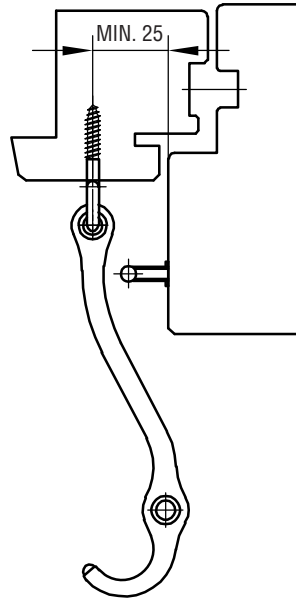

FIG. 2
IPA NO. 21372
WITH 21381

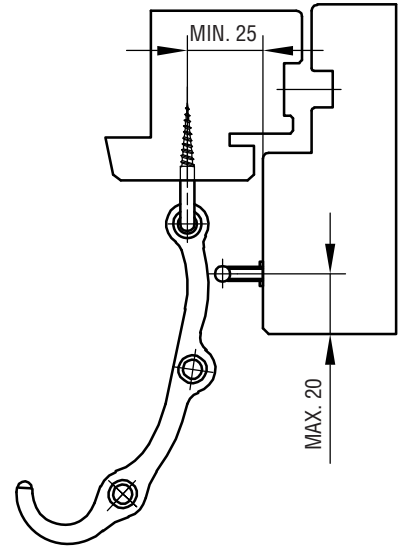

FIG. 3
IPA NO. 21378
WITH 21381

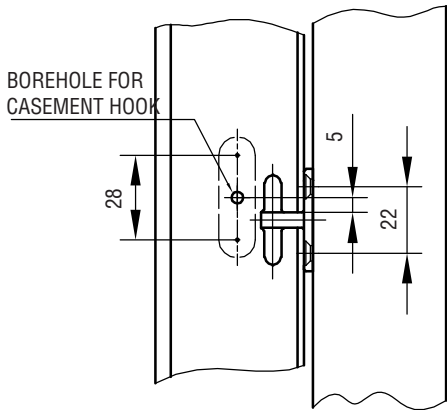

FIG. 4
IPA NO. 21382

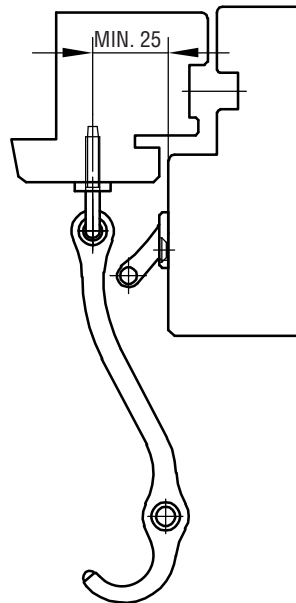

FIG. 5
IPA NO. 21371
WITH 21382

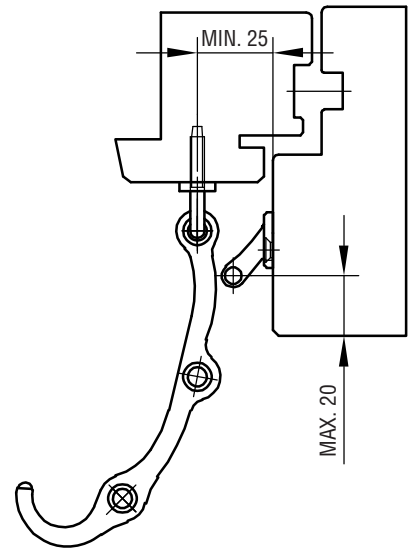
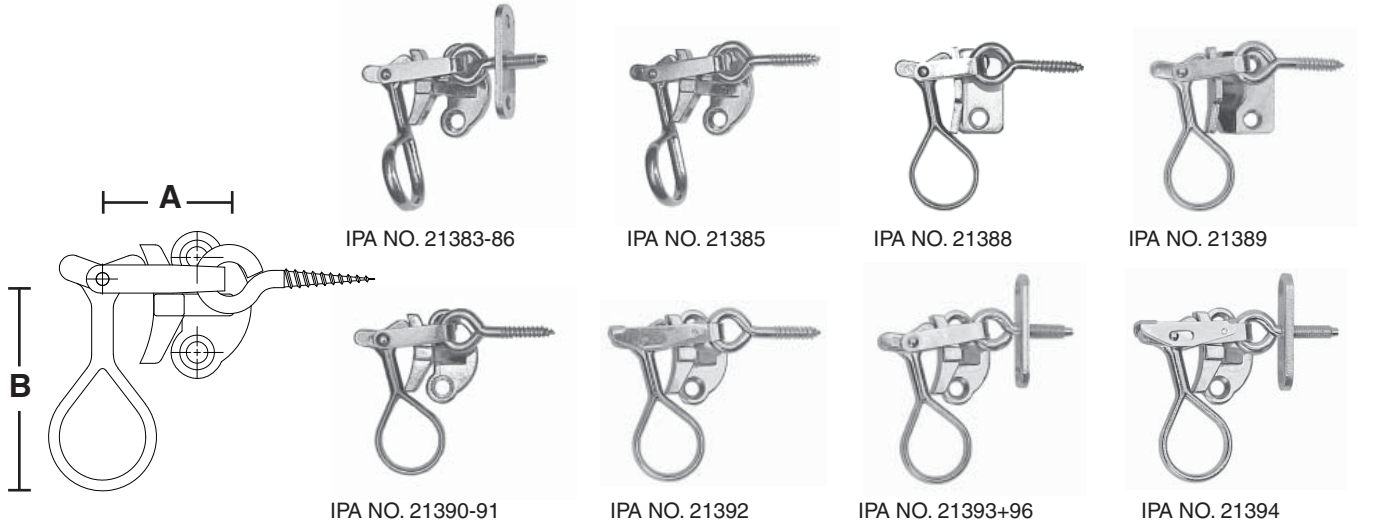

FIG. 6
IPA NO. 21379
WITH 21382



CASEMENT FASTENERS



ORDERING NO.																
IPA NO.	MATERIAL		W/O SPECIFICATION	SURFACE				STANDARD PACKING IN BOXES OF 25 PIECES	STANDARD PACKING IN BOXES OF 50 PIECES	INDUSTRY PACKING IN BOXES OF 200 PIECES	INDUSTRY PACKING IN BOXES OF 500 PIECES	A MM	B MM	SCREW	EYE SCREW	APPROX WEIGHT KGS / 100 PIECES
	STEEL	BRASS		ELECTROPL./WHITE	BROWN	ELECTROPLATED	ELECTROPL./YELLOW									
21383	1	-	0	-	-	21	25	-	-	-	2	24	50	3,5	M5X20	4,00
21385	1	-	0	06	-	21	25	-	-	-	2	28	50	3,5	-	4,00
21386	1	-	0	06	-	21	25	-	-	1	-	28	50	3,5	M5X15	5,00
	1	-	0	-	-	21	25	-	-	-	2					
21388	1	-	0	06	-	21	25	-	-	1	-	21	50	3,5	-	4,00
	1	-	0	-	-	21	25	-	-	-	2					
21389	1	-	0	06	-	21	25	-	-	1	-	24	50	3,5	-	4,60
	1	-	0	-	-	21	25	-	-	-	2					
21390	1	-	0	-	-	21	25	-	-	-	2	24	50	3,5	-	3,80
21391	1	-	0	06	12	21	25	-	-	1	-	28	50	3,5	-	4,00
	1	-	0	06	-	21	25	-	-	-	2					
	-	6	0	-	-	-	-	85	-	1	2					
21392	1	-	0	-	-	21	25	-	-	1	-	28	50	3,5	-	4,40
21393	1	-	0	06	12	21	25	-	-	1	-	28	50	3,5	M5X20	4,40
	1	-	0	06	-	21	25	-	-	-	2					
21394	1	-	0	-	-	21	25	-	1	-	-	28	50	3,5	M5X20	5,00
21396	1	-	0	06	-	21	25	-	-	-	2	24	50	3,5	M5X20	5,00



FITTING INSTRUCTIONS

CASEMENT HOOK WITH
WOOD SCREW

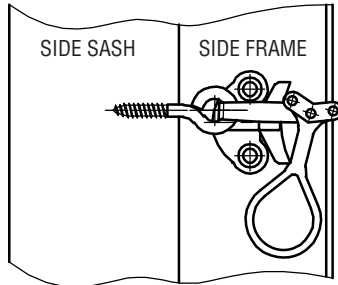

CASEMENT HOOK WITH
SCREW PLATE

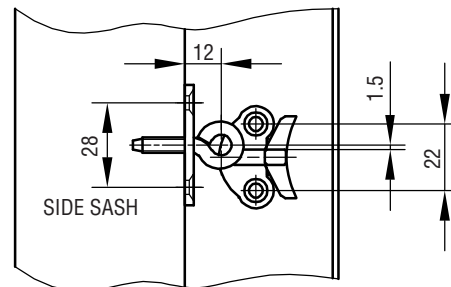
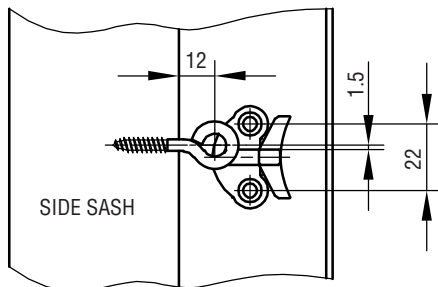
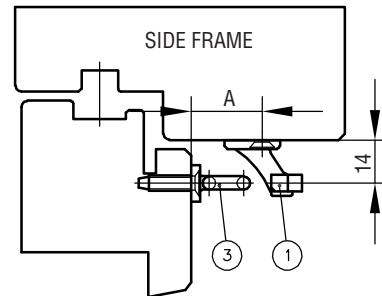
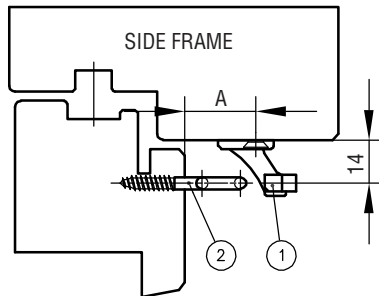
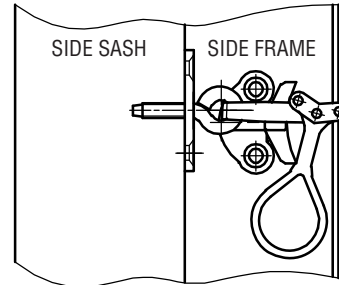

FIG. 1

IPA NO. 21385 + 21388-92

FIG. 2

IPA NO. 21383 + 21386 + 21393-96

IPA NO.	21385 21391-92	21388	21389	21390	21383+96	21386 21393-94
A MM	24	19	11	20	18	22

MOUNTING:

1. MOUNT THE RECEIVER (1), ON SIDE FRAME IN THE WANTED HEIGHT.

2. IPA NO. 21385+21388-92:

MEASURE PRECISELY ON THE SIDE SASH FOR THE CASEMENT HOOK WITH WOOD SCREW (2).

PRE-DRILL A HOLE FOR THE WOOD SCREW. FASTEN THE CASEMENT HOOK WITH WOOD SCREW.

IPA NO. 21383+21386+21393-96:

MEASURE PRECISELY ON THE SIDE SASH FOR THE CASEMENT HOOK WITH SCREW PLATE (3).

PRE-DRILL A 5.0 MM HOLE FOR THE TREATED SCREW AND PRE-DRILL THE HOLES FOR THE WOOD SCREWS. MARK UP FOR THE 2 SCREW HOLES ON THE SASH AND PRE-DRILL THE HOLES. FASTEN THE CASEMENT HOOK WITH SCREW PLATE



MAINTENANCE GENERAL INSTRUCTIONS

GENERALLY all parts of a building have to be looked after and maintained from time to time. This of course also applies for fittings in windows and doors.

How often fittings in windows and doors should be maintained depends to a large extent on how they are used, how often they are operated, and not least on the environment the fittings are exposed to.

Corrosion may also be caused by other factors, such as corrosive liquids, air pollution etc. Special attention should be given to fittings used in windows and doors in urban and industrial areas or other areas with a high traffic intensity as well as coastal areas. Fittings in such environments should be checked and greased more often than fittings used in areas with less corrosive effects.

HINGES AND FITTINGS should be lubricated when necessary, or at the minimum twice a year.

SLIDING ELEMENTS AS WELL AS ALL ALURAILS with sliding surfaces are to be kept clean and free from dust and dirt to ensure a smooth sliding function. Stearin wax or a clean lubricating film (but no oil and no grease!) can be applied onto the aluminium rails.

ESPANOULETTES AND OTHER LOCKING FITTINGS should be greased or lubricated with acid free grease or acid free oil on spray. The grease/oil should be applied into the mechanism box as well as on the joints of the side bolts, the roller bolts, or the mushroom head bolts while activating the mechanism repeatedly. Grease or lubricate when necessary or at the minimum twice a year.

BRASS will sooner or later get some discolouration in a brownish tone depending on the environment in which it is placed. The original brass surface can be maintained by polishing from time to time.

STAINLESS STEEL can get some discolouration, although this rarely happens. Different chemical influences like acid fumes, contamination from wood preservation treatments, or air pollution may cause discoloration of the metal, sometimes to a reddish tone which could look like rust. Thin discoloration can be removed just by using common cleaner or polish.



MAINTENANCE GENERAL INSTRUCTIONS

PAINTED FITTINGS will from time to time need repainting. Before painting all parts should be cleaned carefully. When choosing type of paint and when applying the paint remember to follow the instructions from the paint manufacturer very carefully.

When painting a wooden window in a house, it is a good idea also to paint the visible parts of the fittings (please note: No alurails nor sliding parts should ever be painted!). The painting of the fitting will minimize corrosion and add to the lifetime of the fitting. Always make sure that the proper function of a fitting is not affected by the painting.

ANODIZED ALUMINIUM should be cleaned from time to time, depending on the surroundings in which it is placed. Cleaning of the surface with a cloth or sponge is recommended. Eventually a neutral solvent can be used. Emery cloth, steel wool, sodium carbonate, and other cleansers or abrasives containing alkalies or acid should never be used.

ON THE WINDOW AND DOOR FACTORY SITE all fittings should be lubricated or greased before shipment. Hinges should be lubricated with acidfree oil while activating repeatedly an acidfree grease can also be used. When using grease it should be applied directly onto the pin of the hinges. It may be necessary to dismantle the sash before greasing. Especially hinges with a brass pin should be greased.

When mounting fittings, please make sure that the tools do not damage the original surface treatment. When original surface has been damaged make sure that remedial take place as soon as possible.

**WHEN IN DOUBT PLEASE CONTACT YOUR LOCAL SUPPLIER OR A/S J. PETERSENS
BESLAGFABRIK.**



MAINTENANCE LUBRICATION INSTRUCTIONS

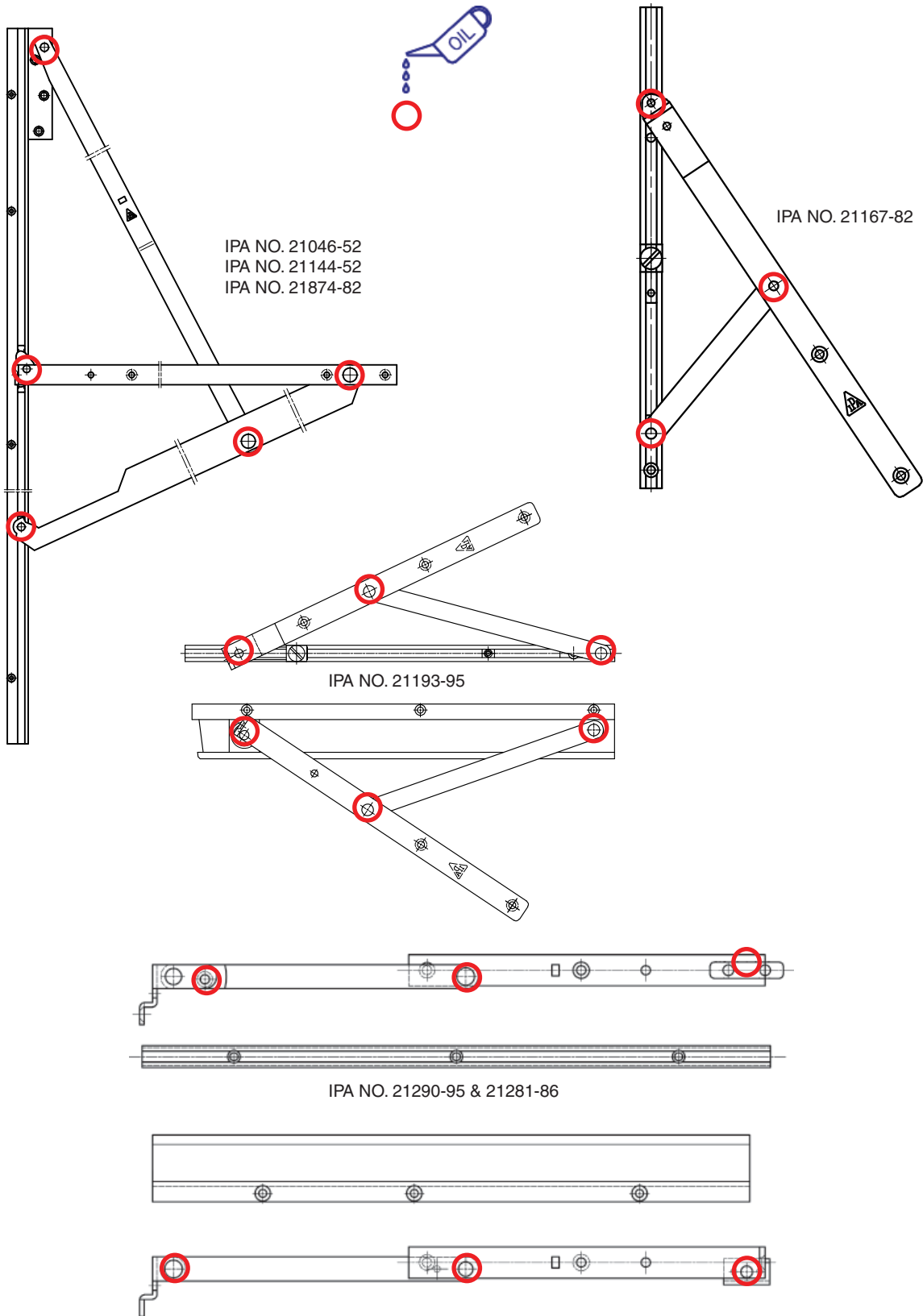

**LUBRICATE BETWEEN THE MOVING PARTS WHILE ACTIVATING REPEATEDLY.
DO NOT GREASE THE ALUMINIUM RAILS.**



MAINTENANCE LUBRICATION INSTRUCTIONS

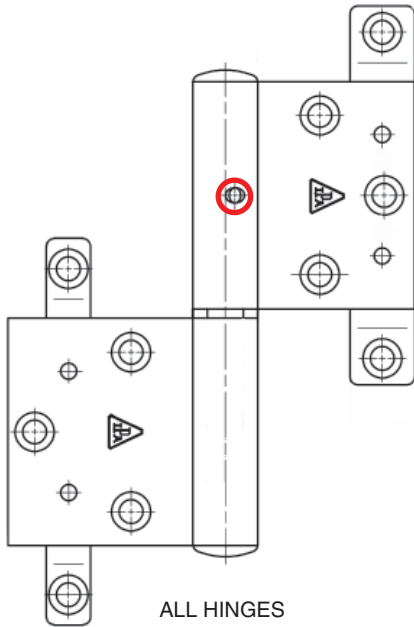

ALL HINGES

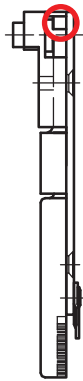

IPA NO. 23782-90

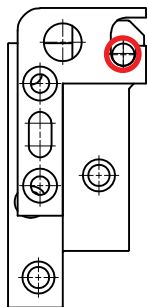

IPA NO. 21125-28

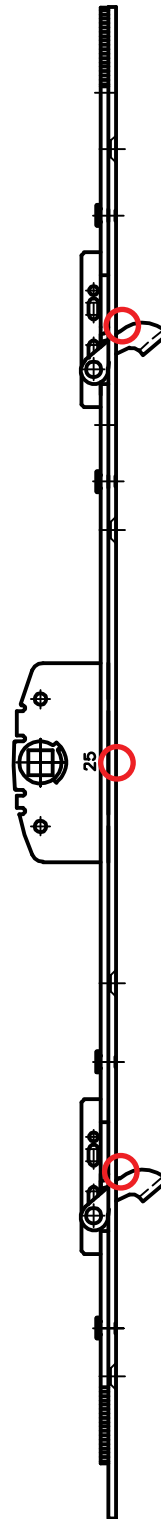

ALL ESPAGNOLETTES

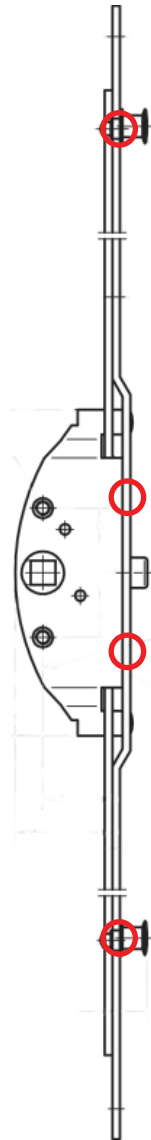

**LUBRICATE BETWEEN THE MOVING PARTS WHILE ACTIVATING REPEATEDLY.
DO NOT GREASE THE ALUMINIUM RAILS.**



IPA NUMBER INDEX

IPA No.	Page
11166	B-01 - B-02
11167	B-01 - B-02
11173	B-01 - B-02
11174	B-01 - B-02
11177	B-01 - B-02
11178	B-01 - B-02
11179	B-01 - B-02
11195	B-03 - B-04
11197	B-03 - B-04
11198	B-03 - B-04
11199	B-03 - B-04
11200	B-03 - B-04
11201	B-03 - B-04
11715	B-05
11717	B-06
11718	B-06
12197	B-07
12198	B-07
12721	G-04
13241	G-03
13243	G-03
21044	C-03 - C-04
21045	C-03 - C-04
21046	C-03 - C-04
21047	C-03 - C-04
21048	C-03 - C-04
21049	C-03 - C-04
21050	C-03 - C-04
21051	C-03 - C-04
21052	C-03 - C-04
21125	C-01
21127	C-02
21128	C-02
21144	C-05 - C-06
21145	C-05 - C-06
21146	C-05 - C-06

IPA No.	Page
21147	C-05 - C-06
21148	C-05 - C-06
21149	C-05 - C-06
21150	C-05 - C-06
21151	C-05 - C-06
21152	C-05 - C-06
21155	G-04
21156	D-13
21157	D-14
21158	D-15
21160	D-01 - D-02
21162	D-16
21163	D-16
21167	C-07 - C-08
21168	C-07 - C-08
21170	C-09 - C-10
21173	C-09 - C-10
21174	C-09 - C-10
21175	C-09 - C-10
21179	C-09 - C-10
21182	C-09 - C-10
21186	C-13 - C-14
21187	C-13 - C-14
21188	C-07 - C-08
21189	C-13 - C-14
21193	B-09 - B-10
21194	B-11 - B-12
21195	B-11 - B-12
21218	D-19 - D-20
21219	D-19 - D-20
21220	D-19 - D-20
21221	G-03
21222	G-03
21223	G-03
21225	G-03
21226	D-12

IPA No.	Page
21227	D-03 - D-04
21228	D-03 - D-04
21229	D-05 - D-06
21230	D-05 - D-06
21231	D-07
21232	D-19 - D-20
21233	D-08
21236	D-11
21281	B-15 - B-16
21282	B-15 - B-16
21283	B-15 - B-16
21284	B-15 - B-16
21285	B-15 - B-16
21286	B-15 - B-16
21290	B-13 - B-14
21291	B-13 - B-14
21292	B-13 - B-14
21293	B-13 - B-14
21294	B-13 - B-14
21295	B-13 - B-14
21311	G-05
21313	G-05
21318	G-04
21321	D-10
21327	G-01
21343	G-05
21345	G-05
21347	G-05
21349	G-05
21351	G-05
21353	G-05
21355	G-05
21357	G-05
21359	G-06
21360	G-06
21361	G-06



IPA NUMBER INDEX

IPA No.	Page
21363	G-06
21369	G-06
21370	G-07
21371	G-07 - G-08
21372	G-07 - G-08
21373	G-07
21376	G-07
21378	G-07 - G-08
21379	G-07 - G-08
21381	G-06 + G-08
21382	G-06 + G-08
21383	G-09 - G-10
21385	G-09 - G-10
21386	G-09 - G-10
21388	G-09 - G-10
21389	G-09 - G-10
21390	G-09 - G-10
21391	G-09 - G-10
21392	G-09 - G-10
21393	G-09 - G-10
21394	G-09 - G-10
21396	G-09 - G-10
21458	G-03
21460	G-03
21541	G-03
21552	G-03
21554	G-03
21562	G-03
21564	G-03
21874	C-11 - C-12
21875	C-11 - C-12
21876	C-11 - C-12
21877	C-11 - C-12
21878	C-11 - C-12
21879	C-11 - C-12
21880	C-11 - C-12

IPA No.	Page
21881	C-11 - C-12
21882	C-11 - C-12
22411	G-02
23051	E-01 - E-02
23052	E-01 - E-02
23053	E-01 - E-02
23054	E-01 - E-02
23055	E-01 - E-02
23056	E-01 - E-02
23057	E-01 - E-02
23058	E-01 - E-02
23059	E-01 - E-02
23060	E-01 - E-02
23061	E-01 - E-02
23062	E-01 - E-02
23063	E-01 - E-02
23064	E-01 - E-02
23065	E-01 - E-02
23066	E-01 - E-02
23067	E-01 - E-02
23068	E-01 - E-02
23069	E-01 - E-02
23070	E-01 - E-02
23121	E-13 - E-14
23122	E-13 - E-14
23123	E-13 - E-14
23124	E-13 - E-14
23131	E-23 - E-24
23132	E-23 - E-24
23133	E-23 - E-24
23134	E-23 - E-24
23141	E-03 - E-04
23142	E-03 - E-04
23143	E-03 - E-04
23144	E-03 - E-04
23145	E-03 - E-04

IPA No.	Page
23146	E-03 - E-04
23147	E-03 - E-04
23148	E-03 - E-04
23151	E-05 - E-06
23152	E-05 - E-06
23153	E-05 - E-06
23154	E-05 - E-06
23156	E-05 - E-06
23158	E-05 - E-06
23160	E-05 - E-06
23161	E-05 - E-06
23162	E-05 - E-06
23163	E-05 - E-06
23164	E-05 - E-06
23166	E-05 - E-06
23168	E-05 - E-06
23170	E-05 - E-06
23180	F-08 + F-09
23181	F-08 + F-09
23182	F-08 + F-09
23183	F-08
23184	F-08
23185	F-08
23186	F-08
23187	F-08
23190	F-09
23191	F-09
23192	F-09
23220	F-10
23221	F-10
23222	F-10
23228	F-14
23229	F-14
23230	G-03
23231	G-03
23233	F-14



IPA NUMBER INDEX

IPA No.	Page
23234	F-14
23238	F-14
23248	F-07
23249	F-07
23250	F-07
23252	F-07
23259	F-07
23260	F-07
23269	F-07
23270	F-07
23285	E-03 - E-04
23286	E-03 - E-04
23301	G-04
23303	G-04
23305	G-04
23308	G-04
23309	G-04
23340	G-04
23448	F-07
23450	F-07
23452	F-07
23460	F-07
23461	E-17 - E-18
23462	E-17 - E-18
23463	E-17 - E-18
23464	E-17 - E-18
23465	E-17 - E-18
23466	E-17 - E-18
23467	E-17 - E-18
23481	E-19 - E-20
23482	E-19 - E-20
23483	E-19 - E-20
23484	E-19 - E-20
23485	E-19 - E-20
23486	E-19 - E-20
23487	E-19 - E-20

IPA No.	Page
23498	E-21 - E-20
23501	G-04
23521	F-10
23531	G-04
23551	E-15 - E-16
23553	E-15 - E-16
23580	F-11 - F-12
23581	F-11 - F-12
23582	F-11 - F-12
23583	F-11 - F-12
23584	F-11 - F-12
23585	F-11 - F-12
23586	F-11 - F-12
23587	F-11 - F-12
23588	F-11 - F-12
23589	F-11 - F-12
23590	F-11 - F-12
23592	F-11 - F-12
23593	F-11 - F-12
23595	F-11 - F-12
23596	F-11 - F-12
23597	F-11 - F-12
23701	E-07 - E-08
23702	E-07 - E-08
23703	E-07 - E-08
23704	E-07 - E-08
23705	E-07 - E-08
23706	E-07 - E-08
23707	E-07 - E-08
23708	E-07 - E-08
23709	E-07 - E-08
23710	E-07 - E-08
23715	E-07 - E-08
23716	E-07 - E-08
23717	E-07 - E-08
23718	E-07 - E-08

IPA No.	Page
23719	E-07 - E-08
23720	E-07 - E-08
23721	E-07 - E-08
23722	E-07 - E-08
23723	E-07 - E-08
23724	E-07 - E-08
23745	E-09 - E-10
23746	E-09 - E-10
23747	E-09 - E-10
23748	E-09 - E-10
23749	E-09 - E-10
23750	E-09 - E-10
23751	E-09 - E-10
23752	E-09 - E-10
23753	E-09 - E-10
23754	E-09 - E-10
23760	E-09 - E-10
23761	E-09 - E-10
23762	E-09 - E-10
23763	E-09 - E-10
23764	E-09 - E-10
23765	E-09 - E-10
23766	E-09 - E-10
23767	E-09 - E-10
23768	E-09 - E-10
23769	E-09 - E-10
23780	F-13
23782	F-05 - F-06
23783	F-05 - F-06
23785	F-05 - F-06
23786	F-05 - F-06
23789	F-05 - F-06
23790	F-05 - F-06
23797	F-01 - F-02
23798	F-01 - F-02
23799	F-01 - F-02

